

FireBox MC25 230V

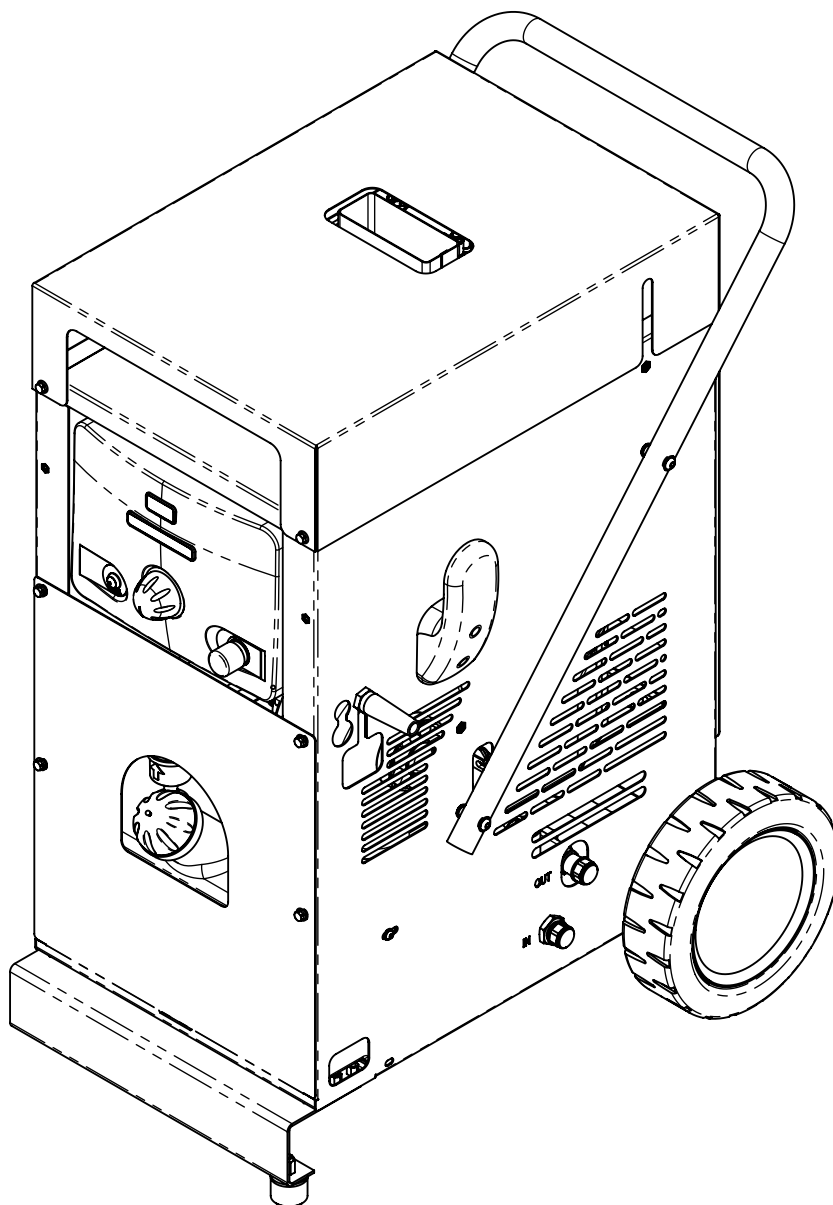

General table

Code	Flow Rate (Lt/min)	Pressure (Bar)	Fuel tank (Lt)	Power Supply (Volt)	In-Out	KW	Kcal/h	Lt/h
3.064.04.015	25	350	16	230 AC	M22X1.5	105	90.000	9.3

General table

Coil		
m	Thickness	Ø
55	2.6	3/8"

Esploded FIREBOX

Esploso FIREBOX

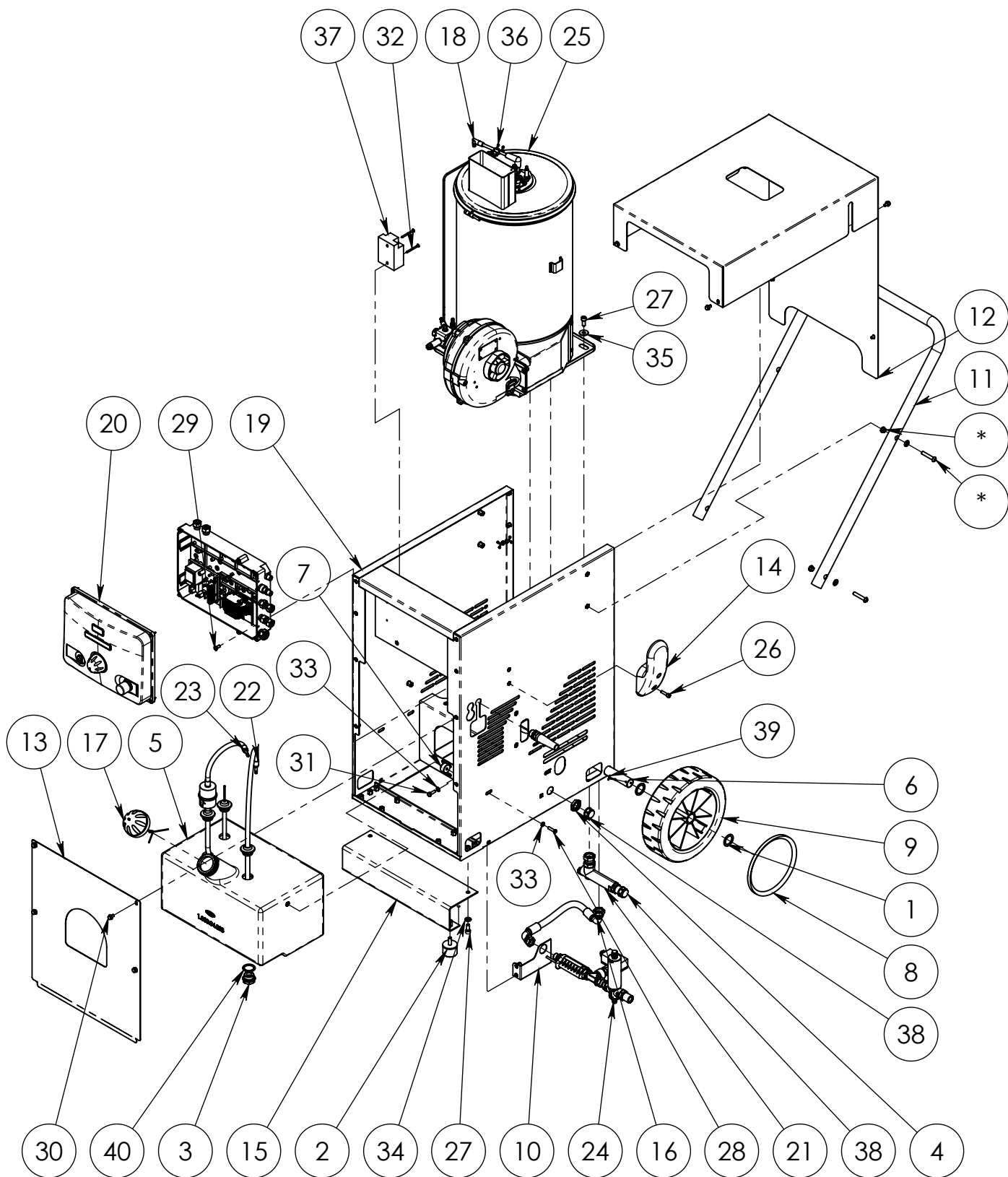

3.064.04.015.I



Pos.	Q.Ty	Code	ITALIANO	ENGLISH	DEUTSCH	ESPAÑOL	FRANCAIS
1	4	1.003.04.006	Rondella ø25.5xø35x2	Washer 25.5x35x2	Unterlegscheibe 25.5x35x2	Arandela 25.5x35x2	Rondelle 25.5x35x2
2	2	1.011.04.018	Supporto	Support	Halter	Soporte	Support
3	1	1.012.14.025	Tappo G3/4	Cap G3/4	Deckel G3/4	Tapón G3/4	Bouchon G3/4
4	1	1.015.04.009	Ghiera M22	Ferrule M22	Zwinge M22	Abrazadera M22	Embout M22
5	1	1.033.04.028	Serbatoio FireBox	Tank FireBox	Tank FireBox	Tanque FireBox	Reservoir FireBox
6	1	1.044.24.084	Tubo	Pipe	Rohr	Tubo	Tuyau
7	3	1.060.02.015	Distanziale ø6.5	Spacer ø6.5	Distanzstueck ø6.5	Distanciador ø6.5	Entretoise ø6.5
8	2	1.085.04.015	Coprimozzo	Hub Cap	Nabe Haus	Casquillo del cubo	Enjoliveur de roue
9	2	1.086.04.018	Ruota ø260 - ø25	Wheel ø260 - ø25	Rad ø260 - ø25	Rueda ø260 - ø25	Roue ø260 - ø25
10	1	1.089.04.074	Staffa	Stirrup	Buegel	Estribo	Étrier
11	1	1.095.04.010	Manico	Handle	Griff	Manija	Manche
12	1	1.125.04.005	Scocca inox	Stainless steel Cover	Edelstahle Abdeckung	Tapa inox	Copot inox
13	1	1.125.04.006	Pannello Anteriore	Front panel	Front-Panel	Panel frontal	Panneau avant
14	1	1.126.04.001	Gancio	Hook	Haken	Gancho	Crochet
15	1	1.145.04.011	Piede	Foot	Fuß	Pie	Pied
16	1	2.006.24.082	Tubo HP 3/8 600B L500	Pipe HP 3/8 600B L500	Rohr HP 3/8 600B L500	Tubo HP 3/8 600B L500	Tuyau HP 3/8 600B L500
17	1	2.013.04.023	Tappo rosso	Red cap	Rote Kappe	Casquillo Rojo	Couvercle rouge
18	1	2.020.04.035	Cavo L=600	Cable L=600	Kabel L=600	Cable L=600	Cable L=600
19	1	2.022.04.013	Basamento	Plinth	Fundament	Zócalo	Embasement
20	1	2.031.04.191	Scatola elettrica 230V 50HZ FIRE BOX	Electric case 230V 50HZ FIRE BOX	Elektrokasten 230V 50HZ FIRE BOX	Caja eléctrica 230V 50HZ FIRE BOX	boîte électrique 230V 50HZ FIRE BOX
21	1	2.048.04.023	Collettore 350BAR FIREBOX	Collector 350BAR FIREBOX	Kollektor 350BAR FIREBOX	Colector 350BAR FIREBOX	Collecteur 350BAR FIREBOX
22	1	2.074.04.068	Tubo by-pass MC	by-pass Pipe MC	by-passRohr MC	Tubo by-pass MC	Tuyau by-pass MC
23	1	2.074.04.070	Tubo aspirazione gasolio FIREBOX	Gas oil suction pipe FIREBOX	Saugrohr gas oel FIREBOX	Tubo de aspiración gasoleo FIREBOX	Tube d'aspiration gas oil FIREBOX
24	1	2.100.04.015	Valvola di sicurezza 400BAR	Safety pressure valve 400BAR	Max druck Einstellungsventile 400BAR	Valvula de seguridad 400BAR	Soupape de sécurité 400BAR
25	1	3.026.04.062	Caldaia 25L/min 230V 400BAR FIREBOX	Boiler 25L/min 230V 400BAR FIREBOX	Kessel 25L/min 230V 400BAR FIREBOX	Caldera 25L/min 230V 400BAR FIREBOX	Chaudière 25L/min 230V 400BAR FIREBOX
26	2	4.002.12.008	Vite M6x25 UNI5931	Screw M6x25 UNI5931	Schrauben M6x25 UNI5931	Tornillo M6x25 UNI5931	Vis M6x25 UNI5931
27	5	4.002.14.005	Vite M8x20 UNI5931	Screw M8x20 UNI5931	Schrauben M8x20 UNI5931	Tornillo M8x20 UNI5931	Vis M8x20 UNI5931
28	3	4.002.14.046	Vite M6x25 ISO7380 ZEB	Screw M6x25 ISO7380 ZEB	Schrauben M6x25 ISO7380 ZEB	Tornillo M6x25 ISO7380 ZEB	Vis M6x25 ISO7380 ZEB
29	4	4.002.24.003	Vite M6x16 UNI5933	Screw M6x16 UNI5933	Schrauben M6x16 UNI5933	Tornillo M6x16 UNI5933	Vis M6x16 UNI5933
30	10	4.002.41.001	Vite M6X10 DIN6921	Screw M6X10 DIN6921	Schrauben M6X10 DIN6921	Tornillo M6X10 DIN6921	Vis M6X10 DIN6921
31	2	4.002.44.001	Vite M6x20 UNI5739	Screw M6x20 UNI5739	Schrauben M6x20 UNI5739	Tornillo M6x20 UNI5739	Vis M6x20 UNI5739
32	2	4.002.94.019	Vite autofilettante 3.9x45 AB D7982	Self-tapping Screw 3.9x45 AB D7982	Selbschneidendeschraube 3.9x45 AB D7982	Tornillo autoblocante 3.9x45 AB D7982	Vis autofiletant 3.9x45 AB D7982
33	5	4.008.02.004	Rondella 12.5x6.3 x1.6	Washer 12.5x6.3 x1.6	Unterlegscheibe 12.5x6.3 x1.6	Arandela 12.5x6.3 x1.6	Rondelle 12.5x6.3 x1.6
34	2	4.008.04.002	Rondella M8 UNI6592	Washer M8 UNI6592	Unterlegscheibe M8 UNI6592	Arandela M8 UNI6592	Rondelle M8 UNI6592
35	3	4.008.24.002	Rondella ø8.5x24x2.5 6593	Washer ø8.5x24x2.5 6593	Unterlegscheibe ø8.5x24x2.5 6593	Arandela ø8.5x24x2.5 6593	Rondelle ø8.5x24x2.5 6593
36	3	4.022.04.016	Fascetta 2x ø5.1/ø7.6	Clamp 2x ø5.1/ø7.6	Klemme 2x ø5.1/ø7.6	Faja 2x ø5.1/ø7.6	Petit bande 2x ø5.1/ø7.6
37	1	4.030.04.010	Trasformatore 30mA 230V	Transformer 30mA 230V	Stromwandler 30mA 230V	Transformador 30mA 230V	Transformateur 30mA 230V
38	2	4.034.04.019	Tappo 1/2 GAS	Cap 1/2 GAS	Deckel 1/2 GAS	Tapón 1/2 GAS	Bouchon 1/2 GAS
39	2	4.044.04.003	Copiglia ø2.5X30 UNI1336	Spit-pin ø2.5X30 UNI1336	Splint ø2.5X30 UNI1336	Chaveta ø2.5X30 UNI1336	Goupille ø2.5X30 UNI1336
40	1	4.070.04.003	Guarnizione 3/4	Gasket G3/4	Dichtung G3/4	Guarnición G3/4	Garniture G3/4

Boiler 25L/min 230V 400BAR FIREBOX

Caldaia 25L/min 230V 400BAR FIREBOX

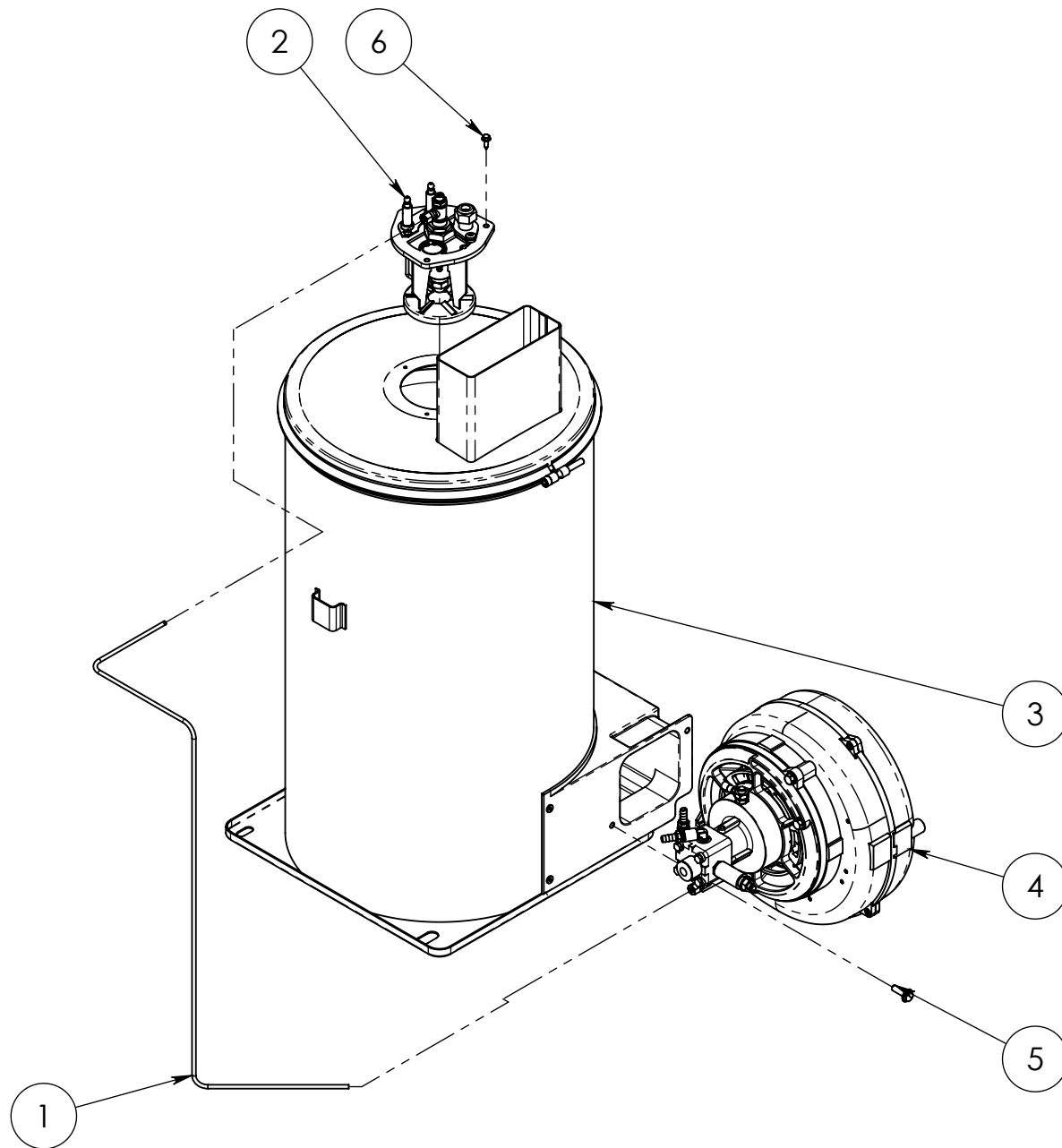

3.026.04.062 .B

Pos.	Q.Ty	Code	ITALIANO	ENGLISH	DEUTSCH	ESPAÑOL	FRANCAIS
1	1	1.044.54.003	Tubo	Pipe	Rohr	Tubo	Tuyau
2	1	2.012.04.033	Coperchio elettrodi W5050	Electrodes cover W5050	Elektrodendeckel W5050	Tapón electrodos W5050	Coouvercle électrodes W5050
3	1	2.041.04.029	Caldaia 25L/min 400BAR FIREBOX	Boiler 25L/min 400BAR FIREBOX	Kessel 25L/min 400BAR FIREBOX	Caldera 25L/min 400BAR FIREBOX	Chaudière 25L/min 400BAR FIREBOX
4	1	3.038.02.011	Convogliatore 230V 50/60Hz	Conveyor 230V 50/60Hz	Foerderer 230V 50/60Hz	Convoyador 230V 50/60Hz	Conveyeur 230V 50/60Hz
5	2	4.002.92.011	Vite M6x20 UNI 8111	Screw M6x20 UNI 8111	Schrauben M6x20 UNI 8111	Tornillo M6x20 UNI 8111	Vis M6x20 UNI 8111
6	3	4.002.94.017	Vite autofilettante 3.9x13	Self-tapping Screw 3.9x13	Selbschneidendeschraube 3.9x13	Tornillo autoblocante 3.9x13	Vis autofiletant 3.9x13

Electrodes cover W5050

Coperchio elettrodi W5050

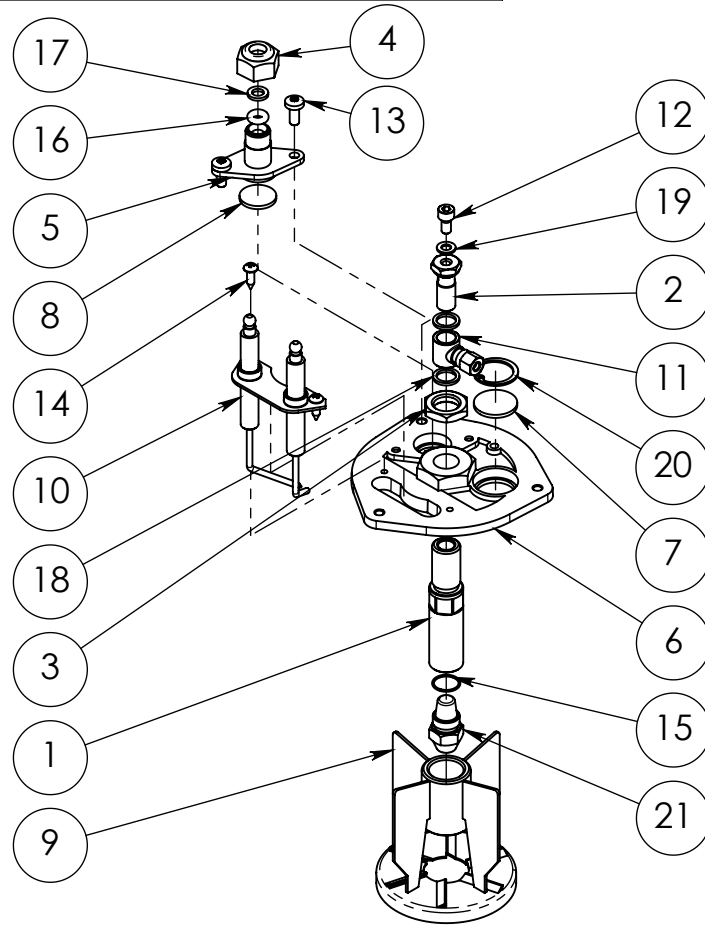

2.012.04.033.E

Pos.	Q.Ty	Code	ITALIANO	ENGLISH	DEUTSCH	ESPAÑOL	FRANCAIS
1	1	1.001.04.006	Raccordo 9/19 - G1/8	Connection 9/19 - G1/8	Leiste 9/19 - G1/8	Filete 9/19 - G1/8	Filet 9/19 - G1/8
2	1	1.012.14.012	Tappo G1/8+CONTR.PRESS.M5	Cap G1/8+CONTR.PRESS.M5	Deckel G1/8+CONTR.PRESS.M5	Tapón G1/8+CONTR.PRESS.M5	Bouchon G1/8+CONTR.PRESS.M5
3	1	1.015.24.003	Ghiera	Ferrule	Zwinge	Abrazadera	Embout
4	1	1.015.32.008	Ghiera G1/4"	Ferrule G1/4"	Zwinge G1/4"	Abrazadera G1/4"	Embout G1/4"
5	1	1.074.04.005	Flangia	Flange	Flansch	Borde	Bride
6	1	1.074.04.018	Flangia M15x1.5 (CF)	Flange M15x1.5 (CF)	Flansch M15x1.5 (CF)	Borde M15x1.5 (CF)	Bride M15x1.5 (CF)
7	1	1.102.04.001	Vetrino	Glass	Glass	Vidrio	Vèrre
8	1	1.102.04.003	Vetrino ø19	Glass ø19	Glass ø19	Vidrio ø19	Vèrre ø19
9	1	2.009.04.002	Deflettore Work	Deflector Work	Deflektor Work	Deflector Work	Défecteur Work
10	1	2.032.04.004	Elettrodi	Electrodes	Elektrode	Electrodos	Electrodes
11	1	3.050.34.001	Raccordo	Connection	Leiste	Filete	Filet
12	1	4.002.14.022	Vite M5x10 UNI5931	Screw M5x10 UNI5931	Schrauben M5x10 UNI5931	Tornillo M5x10 UNI5931	Vis M5x10 UNI5931
13	2	4.002.72.001	Vite M5x12 UNI7687	Screw M5x12 UNI7687	Schrauben M5x12 UNI7687	Tornillo M5x12 UNI7687	Vis M5x12 UNI7687
14	2	4.002.94.005	Vite autofilettante 3.9x13	Self-tapping Screw 3.9x13	Gewindeschneidschraube 3.9x13	Tornillo Self-tapping 3.9x13	Vies Autofilettante 3.9x13
15	1	4.005.14.004	OR 0130-1	O-ring 0130-1	O-ring 0130-1	OR 0130-1	Joint torique 0130-1
16	1	4.005.24.013	Guarnizione OR ø4.34X3.53	Gasket OR ø4.34X3.53	Dichtung OR ø4.34X3.53	Guarnición OR ø4.34X3.53	Garniture OR ø4.34X3.53
17	1	4.008.02.001	Rondella 6.4x11x1.6 DIN433 UNI6592 ZEB	Washer 6.4x11x1.6 DIN433 UNI6592 ZEB	Unterlegscheibe 6.4x11x1.6 DIN433 UNI6592 ZEB	Arandela 6.4x11x1.6 DIN433 UNI6592 ZEB	Rondelle 6.4x11x1.6 DIN433 UNI6592 ZEB
18	2	4.008.12.005	Rondella Rame G1/8	Copper washer G1/8	Kupferunterlegsscheibe G1/8	Arandelade cobre G1/8	Rondelle cuivre G1/8
19	1	4.008.14.003	Rondella Rame M5	Copper washer M5	Kupferunterlegsscheibe M5	Arandela de cobre M5	Rondelle cuivre M5
20	1	4.025.04.002	Seeger	Seeger	Seeger	Seeger	Seeger
21	1	4.027.14.012	Ugello 2.25	Nozzle 2.25	Duse 2.25	Boquilla 2.25	Buse 2.25

Preassembled Boiler 25L/min 400BAR FIREBOX

Premontato Caldaia 25L/min 400BAR FIREBOX

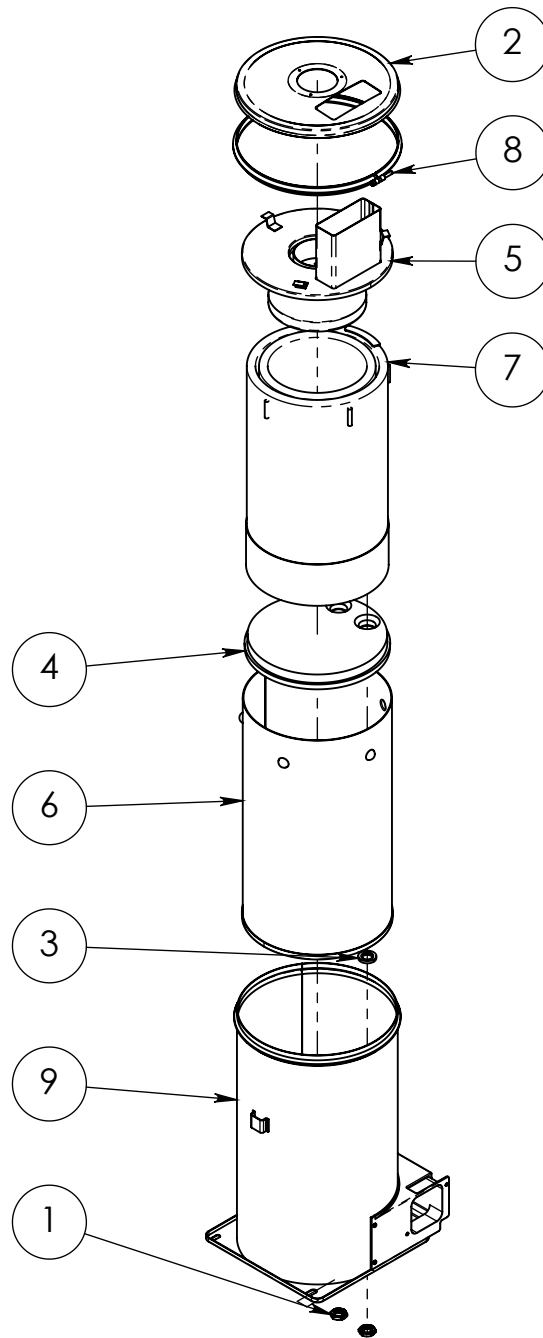

2.041.04.029.A

Pos.	Q.Ty	Code	ITALIANO	ENGLISH	DEUTSCH	ESPAÑOL	FRANCAIS
1	2	1.015.24.002	Ghiera 1/2"G	Ferrule 1/2"G	Zwinge 1/2"G	Abrazadera 1/2"G	Embout 1/2"G
2	1	1.054.04.006	Coperchio	Cover	Deckel	Tapa	Couvercle
3	2	1.060.04.018	Distanziale	Spacer	Distanzstueck	Distanciador	Entretoise
4	1	1.094.04.005	Isolante termico 20-25L	Thermal insulator 20-25L	Waermeschutzstoff 20-25L	Aislador termal 20-25L	Isolateur termique 20-25L
5	1	2.012.04.013	Coperchio W 20L	Cover W 20L	Deckel W 20L	Tapa W 20L	Couvercle W 20L
6	1	2.023.04.010	Camicia interna 25L	Internal jacket 25L	Innerer Mantel 25L	Camisa interior 25L	Chemise interne 25L
7	1	2.029.02.001	Serpentina 25Lit 400Bar 3/8"M-M	Coil 25Lit 400Bar 3/8"M-M	Schlange 25Lit 400Bar 3/8"M-M	Serpentin 25Lit 400Bar 3/8"M-M	Serpentin 25Lit 400Bar 3/8"M-M
8	1	2.056.04.001	Fascetta ø317	Clamp ø317	Klemme ø317	Faja ø317	Petit bande ø317
9	1	2.111.04.002	Camicia esterna PH4000	External jacket PH4000	Äusserer Mantel PH4000	Camisa externa PH4000	Chemise externe PH4000

Conveyor 230V 50/60Hz

Convogliatore 230V 50/60Hz

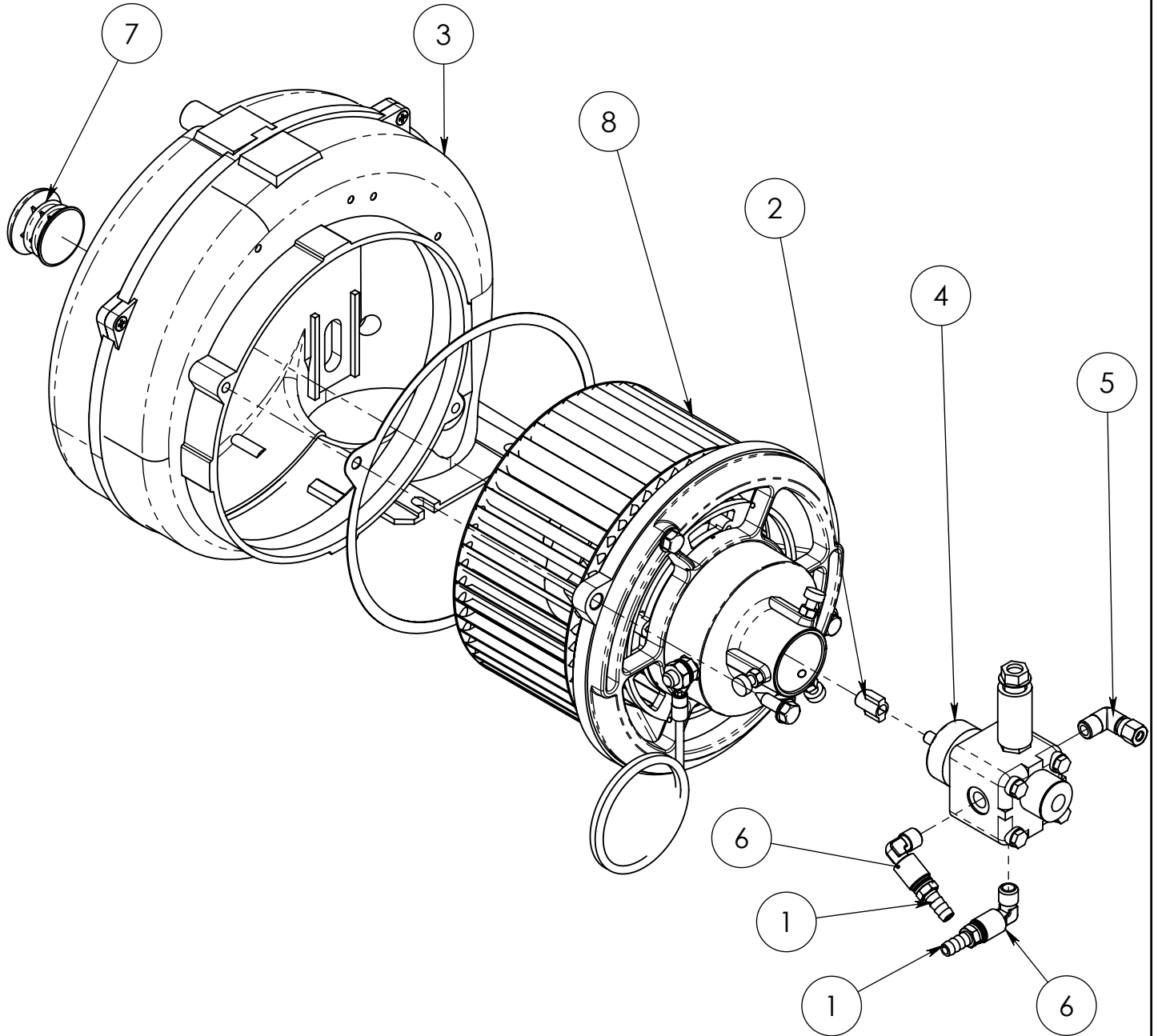

KIT CONVEYOR MOTOR REPLACEMENT: 9.014.02.008

3.038.02.011.K

Pos.	Q.tà	Cod.	ITALIANO	ENGLISH	DEUTSCH	ESPAÑOL	FRANCAIS
1	2	1.005.04.002	Innesto rapido	Quick coupling	Schnelle kupplung	Enchufe rapido	Raccord rapid
2	1	1.098.02.001	Giunto DX	Coupling DX	Kupplung DX	Acoplamiento DX	Accouplement DX
3	1	2.017.22.002	Carter 5050	Guard 5050	Gehäuse 5050	Càrter 5050	Carter 5050
4	1	3.015.24.007	Pompa DX	Pump DX	Pump DX	Bomba DX	Pompe DX
5	1	3.050.14.001	Raccordo	Connection	Leiste	Filete	Filet
6	2	4.012.04.013	Raccordo a L G1/4	L Connection G1/4	Leiste L G1/4	Filete L G1/4	Filet L G1/4
7	1	4.036.02.002	Tappo ø32	Plug ø32	Deckel ø32	Tapón ø32	Bouchon ø32
8	1	9.014.02.008	Ricambio Motore Elettrico 220VMF2P DX	Electric Motor Spare part 220VMF2P DX	ElektromotorErsatzteil 220VMF2P DX	Motor Eléctrico de repuesto 220VMF2P DX	Moteur électrique de rechange 220VMF2P DX

Electric case 230V 50HZ FIRE BOX

Scatola elettrica 230V 50HZ FIRE BOX

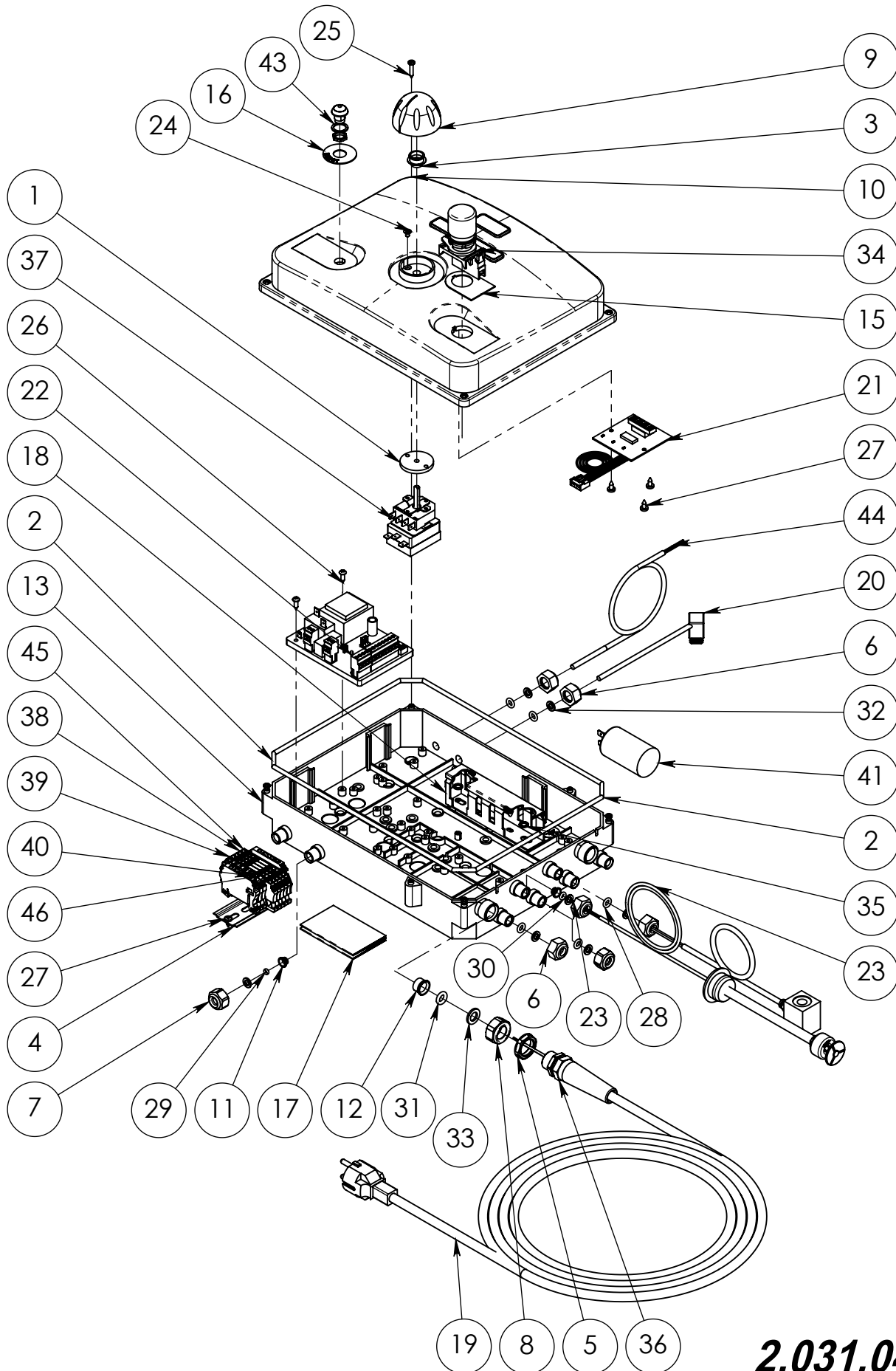

2.031.04.191.N



Pos.	Q.Ty	Code	ITALIANO	ENGLISH	DEUTSCH	ESPAÑOL	FRANCAIS
1	1	1.006.14.001	Guarnizione ø36	Gasket ø36	Dichtung ø36	Guarnición ø36	Garniture ø36
2	1	1.006.14.004	Guarnizione ø4x1020	Gasket ø4x1020	Dichtung ø4x1020	Guarnición ø4x1020	Garniture ø4x1020
3	1	1.006.14.012	Guarnizione	Gasket	Verzierung	Guarnición	Garniture
4	1	1.011.04.033	Supporto L 73mm	Support L 73mm	Halter L 73mm	Soporte L 73mm	Support L 73mm
5	1	1.015.04.003	Ghiera Pg13.5	Ferrule Pg13.5	Zwinge Pg13.5	Abrazadera Pg13.5	Embout Pg13.5
6	5	1.015.32.008	Ghiera G1/4"	Ferrule G1/4"	Zwinge G1/4"	Abrazadera G1/4"	Embout G1/4"
7	2	1.015.32.008	Ghiera G1/4"	Ferrule G1/4"	Zwinge G1/4"	Abrazadera G1/4"	Embout G1/4"
8	1	1.015.32.015	Ghiera 1/2 G-F Pl. 15	Ferrule 1/2 G-F Pl. 15	Zwinge 1/2 G-F Pl. 15	Abrazadera 1/2 G-F Pl. 15	Embout 1/2 G-F Pl. 15
9	1	1.021.04.006	Manopla	Knob	Griff	Pomo	Poignée
10	1	1.054.04.055	Coperchio scatola elettrica	Electrical box cover	Elektro-Deckel	Cubierta de la caja eléctrica	Couverture de boîte électrique
11	2	1.064.04.010	Boccola	Bushing	Buchse	Buje	Boucle
12	1	1.064.04.024	Pressacavo ø12	Cable clamping ø12	Kabelklemme ø12	Prensacables ø12	Serre-câble ø12
13	1	1.078.04.060	Scatola Q-E FIRE-Box	Box Q-E FIRE-Box	Kasten Q-E FIRE-Box	Caja Q-E FIRE-Box	Boite Q-E FIRE-Box
14	1	1.087.04.093	Etichetta	Label	Etikett	Etiqueta	Étiquette
15	1	1.087.04.301	Etichetta	Label	Etikett	Etiqueta	Étiquette
16	1	1.087.04.303	Etichetta reset	Label reset	Etikett reset	Etiqueta reset	Étiquette reset
17	1	1.093.04.149	Schema elettrico	electric diagram	elektrisches Schema	electric diagram	schéma électrique
18	1	1.110.04.003	Canaletta T1 25x40 G L140	Groove T1 25x40 G L140	Nut T1 25x40 G L140	Surco T1 25x40 G L140	Cannelure T1 25x40 G L140
19	1	2.020.04.004	Cavo elettrico S1.5x3 6M	Power cable S1.5x3 6M	Energie kabel S1.5x3 6M	Cable electrico S1.5x3 6M	Cable électrique S1.5x3 6M
20	1	2.020.04.093	Cavo elettrico WSF3025	Power cable WSF3025	Energie kabel WSF3025	Cable electrico WSF3025	Cable électrique WSF3025
21	1	3.024.02.038	Scheda led 12-24-220-400V	Board led 12-24V	Karte led 12-24V	Tarjeta led 12-24V	Carte led 12-24V
22	1	3.024.02.053	Scheda elettronica MCC-B (220V)	Electronic Board MCC-B (220V)	ElektronischeKarte MCC-B (220V)	Tarjeta electrónico MCC-B (220V)	Carte électronique MCC-B (220V)
23	1	3.030.02.015	Livellostato 180mm	Leveller 180mm	Wasser Niveau 180mm	Nivelador 180mm	Niveleur 180mm
24	2	4.002.72.009	Vite TC M4x6	Screw TC M4x6	Schrauben TC M4x6	Tornillo TC M4x6	Vis TC M4x6
25	4	4.002.92.001	Vite autofilettante 3.5x19	Self-tapping Screw 3.5x19	Selbschneidendeschraube 3.5x19	Tornillo autoblocante 3.5x19	Vis autofiletant 3.5x19
26	2	4.002.94.005	Vite autofilettante 3.9x13	Self-tapping Screw 3.9x13	Gewindeschneidschraube 3.9x13	Tornillo Self-tapping 3.9x13	Vies Autofiletante 3.9x13
27	4	4.002.94.015	Vite autofilettante 3.9x9.5	Self-tapping Screw 3.9x9.5	Selbschneidendeschraube 3.9x9.5	Tornillo autoblocante 3.9x9.5	Vis autofiletant 3.9x9.5
28	5	4.005.22.009	OR 3024	O-ring 3024	O-ring 3024	OR 3024	Joint torique 3024
29	1	4.005.22.012	OR 2-105	O-ring 2-105	O-ring 2-105	OR 2-105	Joint torique 2-105
30	1	4.005.22.012	OR 2-105	O-ring 2-105	O-ring 2-105	OR 2-105	Joint torique 2-105
31	1	4.005.22.028	OR 0080-35	O-ring 0080-35	O-ring 0080-35	OR 0080-35	Joint torique ORM 0080-35
32	7	4.008.02.001	Rondella 6.4x11x1.6 DIN433 UNI6592 ZEB	Washer 6.4x11x1.6 DIN433 UNI6592 ZEB	Unterlegscheibe 6.4x11x1.6 DIN433 UNI6592 ZEB	Arandela 6.4x11x1.6 DIN433 UNI6592 ZEB	Rondelle 6.4x11x1.6 DIN433 UNI6592 ZEB
33	1	4.008.04.012	Rondella M10 10.5x18x2	Washer M10 10.5x18x2	Unterlegscheibe M10 10.5x18x2	Arandela M10 10.5x18x2	Rondelle M10 10.5x18x2
34	1	4.018.04.020	Interruttore	Switch	Schalter	Interruptor	Interrupteur
35	2	4.025.04.008	Seeger KS 6	Seeger KS 6	Seeger KS 6	Seeger KS 6	Seeger KS 6
36	1	4.026.02.001	Pressacavo PG 13.5	Cable clamping PG 13.5	Kabelklemme PG 13.5	Prensacables PG 13.5	Serre-câble PG 13.5
37	1	4.031.04.003	Termostato 30°-150°	Thermostat 30°-150°	Thermostat 30°-150°	Termostato 30°-150°	Thermostat 30°-150°
38	1	4.033.04.038	Morsetteria 2.5/4 ZPE 160866	Terminal Block 2.5/4 ZPE 160866	Klemmleisten 2.5/4 ZPE 160866	Tableros de bornes 2.5/4 ZPE 160866	Plaques à bornes 2.5/4 ZPE 160866
39	4	4.033.04.039	Morsetto	Clamp	Klemme	Prensita de sujeción	Colier de serrage
40	2	4.033.04.040	Morsetto	Clamp	Klemme	Prensita de sujeción	Colier de serrage
41	1	4.035.02.017	Condensatore 8mf 450V	Condenser 8mf 450V	Kondensator 8mf 450V	Condensador 8mf 450V	Condenseur 8mf 450V
42	1	4.040.04.001	Bobina	Solenoid	Bandspule	Bobina	Bobine
43	1	4.053.04.005	Pulsante Reset (L=400mm) + Plug	Button Reset (L=400mm) + Plug	Drucktaste Reset (L=400mm) + Plug	Pulsante Reset (L=400mm) + Plug	Bouton Reset (L=400mm) + Plug
44	1	4.069.04.002	Sonda controllo fiamma	Flame control probe	Flamme-Sonde	Sensor de llama	sonde de contrôle de flamme
45	1	4.093.04.002	Terminale ZAP/TW3 N160880	Terminal ZAP/TW3 N160880	Schuh ZAP/TW3 N160880	Terminal ZAP/TW3 N160880	Boîtes d'extrémité ZAP/TW3 N160880
46	2	4.093.04.004	Morsetto	Clamp	Klemme	Prensita de sujeción	Colier de serrage

Safety pressure valve 400BAR

Valvola di sicurezza 400BAR

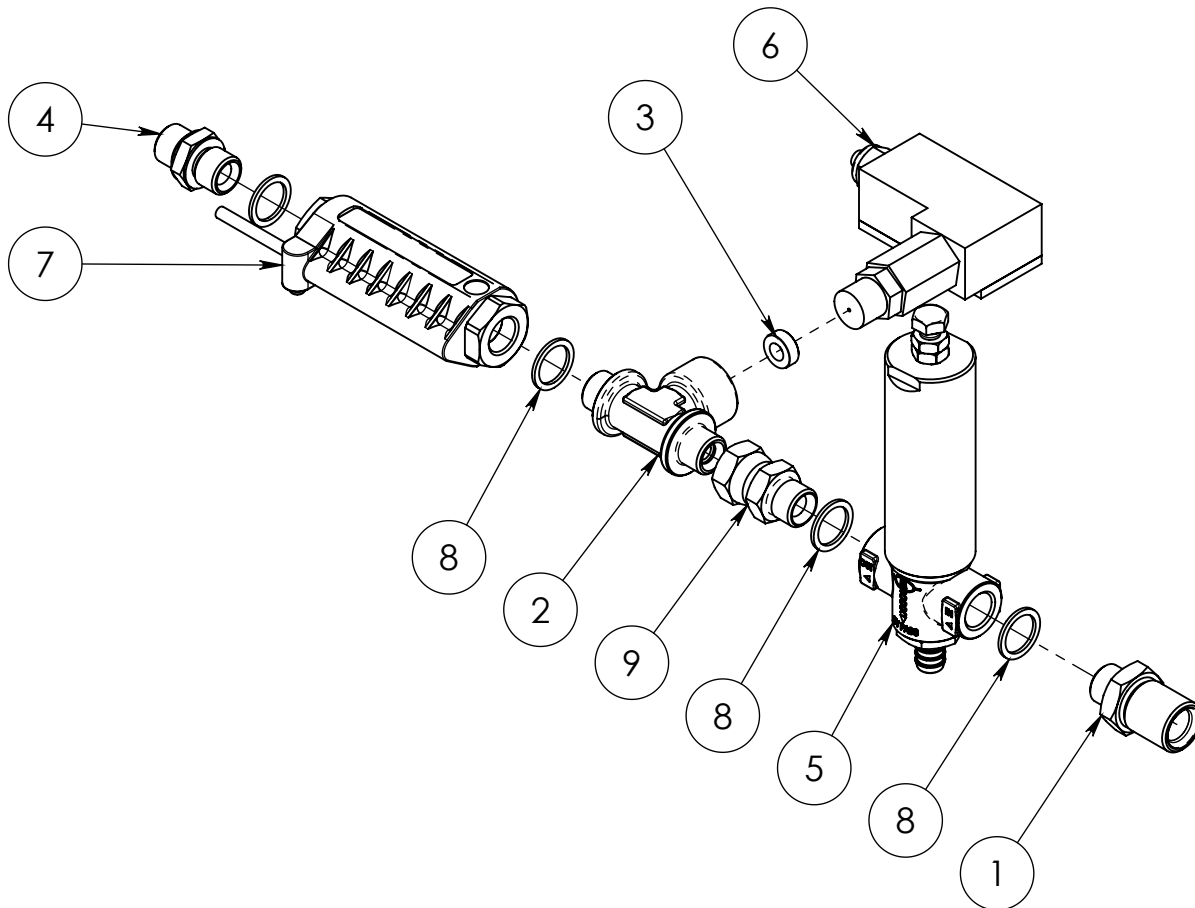

2.100.04.015.E

Pos.	Q.Ty	Code	ITALIANO	ENGLISH	DEUTSCH	ESPAÑOL	FRANCAIS
1	1	1.001.04.052	Raccordo M22x1.5M - G3/8M	Connection M22x1.5M - G3/8M	Leiste M22x1.5M - G3/8M	Filete M22x1.5M - G3/8M	Filet M22x1.5M - G3/8M
2	1	1.001.24.023	Raccordo a T G3/8 M -M-F	T Connection G3/8 M -M-F	Leiste T G3/8 M -M-F	Filete T G3/8 M -M-F	Filet T G3/8 M -M-F
3	1	1.006.22.001	Guarnizione ø14.7xø7.7x5.3	Gasket ø14.7xø7.7x5.3	Dichtung ø14.7xø7.7x5.3	Guarnición ø14.7xø7.7x5.3	Garniture ø14.7xø7.7x5.3
4	1	1.096.04.001	Nipples	Nipples	Nipples	Nipples	Nipples
5	1	3.003.22.010	Valvola di sicurezza 400bar G3/8-FF	Safety pressure valve 400bar G3/8-FF	Max druck Einstellungsventile 400bar G3/8-FF	Valvula de seguridad 400bar G3/8-FF	Soupape de sécurité 400bar G3/8-FF
6	1	3.013.04.011	Pressostato 3/8"Gas max 600Bar INOX	pressure gauge 3/8"Gas max 600Bar INOX	Druckschalter 3/8"Gas max 600Bar INOX	Presostato 3/8"Gas max 600Bar INOX	Pressostat 3/8"Gas max 600Bar INOX
7	1	3.054.04.003	Flussostato 350B	Flow switch 350B	Stromschalter 350B	Flusostato 350B	Flussostat 350B
8	4	4.008.12.001	Rondella Rame G3/8	Copper washer G3/8	Kupferunterlegsscheibe G3/8	Arandela de cobre G3/8	Rondelle cuivre G3/8
9	1	4.012.04.002	Raccordo G3/8	Connection G3/8	Leiste G3/8	Filete G3/8	Filet G3/8

Collector 350BAR FIREBOX

Collettore 350BAR FIREBOX

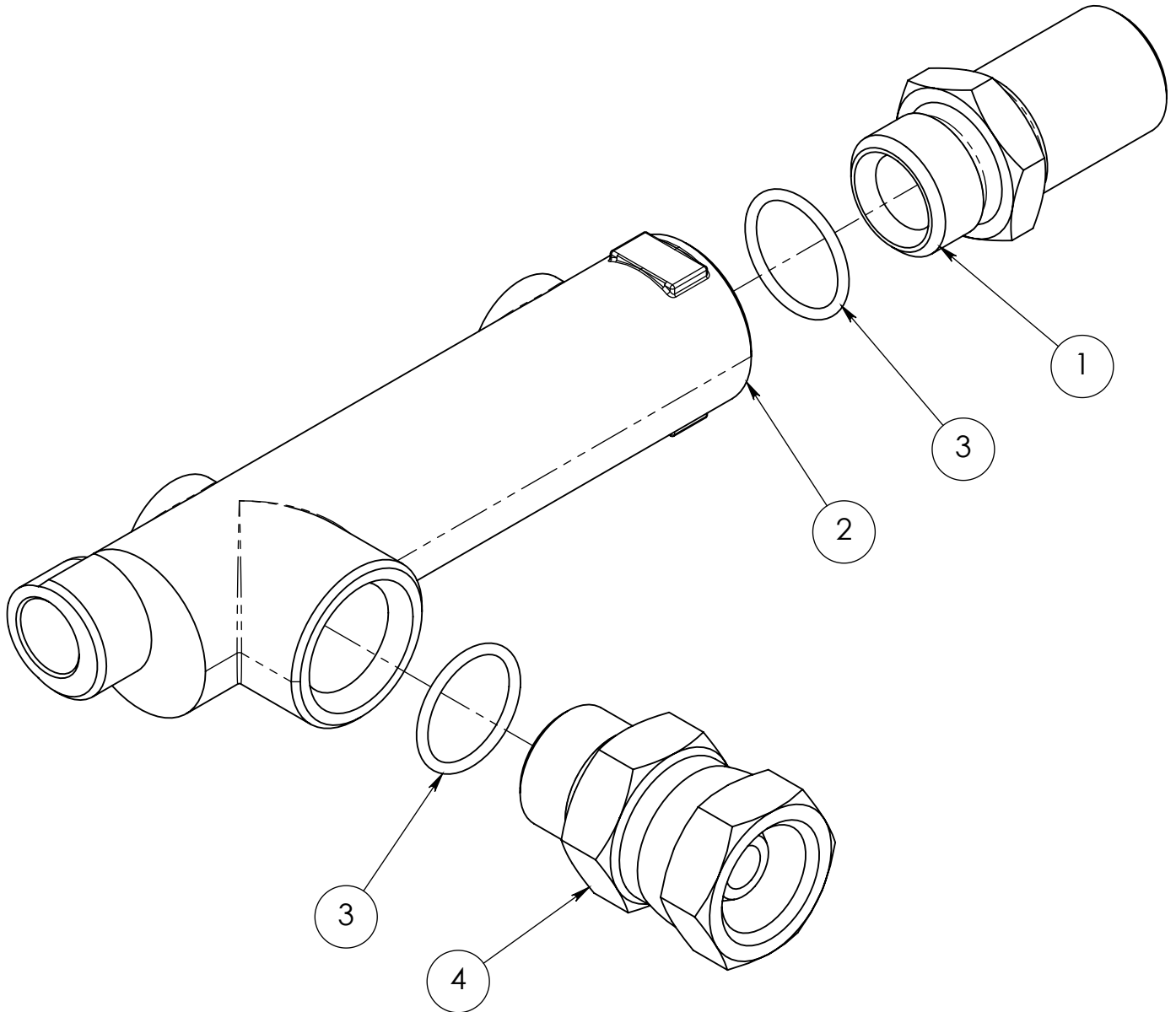

2.048.04.023 .G

Pos.	Q.Ty	Code	ITALIANO	ENGLISH	DEUTSCH	ESPAÑOL	FRANCAIS
1	1	1.001.04.030	Raccordo M22x1.5M-G1/2M	Connection M22x1.5M-G1/2M	Leiste M22x1.5M-G1/2M	Filete M22x1.5M-G1/2M	Filet M22x1.5M-G1/2M
2	1	1.042.24.007	Collettore 500 BAR	Collector 500 BAR	Kollektor 500 BAR	Colector 500 BAR	Collecteur 500 BAR
3	2	4.005.14.002	OR 2075	O-ring 2075	O-ring 2075	OR 2075	Joint torique 2075
4	1	4.012.04.003	Raccordo G1/2 MF	Connection G1/2 MF	Leiste G1/2 MF	Filete G1/2 MF	Filet G1/2 MF