

P.A. – S.p.A. – EQUIPAGGIAMENTI TECNICI DEL LAVAGGIO

VIA MILANO, 13 – CASELLA POSTALE 115 – 42048 RUBIERA (REGGIO EMILIA) – ITALY
 Tel. +39 0522 623611 – Fax. +39 0522 629600 – R.E.A. RE 156319 – R.I. RE11535 – Mecc. RE 013446
 C.F. e P. IVA 01035950359 – Cap. Soc. i.v. € 750.000,00 – Codice Identificativo C.E.E. IT 01035950359
 ART. 2497 – BIS C.C. DIREZIONE E COORDINAMENTO BENETTI srl R.I. TRIB. DI RE 01480690351
 Web: <http://www.pa-etl.it> – E-mail: info@pa-etl.it



RB 65 – Adjustable spray wash gun for food industry - 24 bar – 2.4 MPa

 Technical manual : **E 123**

Guns suitable for use up to 24 bar – 2.4 MPa rated pressure pumps.
 Shockproof gun with adjustable conical/pencil jet.

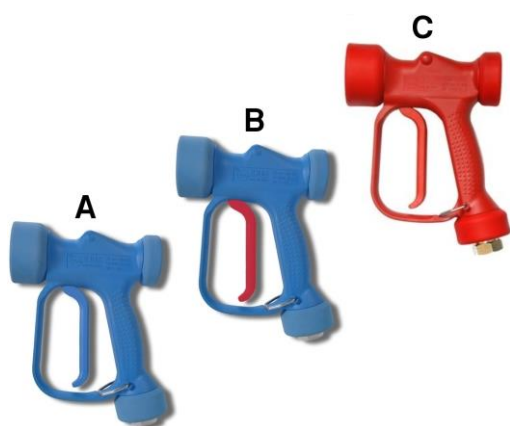
DN15

- **30.6400.00** RB65 G1/2 F ——— **A**
- **30.6425.00** RB65 w/SWIVEL G1/2 F ——— **A**
- **30.6440.00** RB65 G1/2 F ——— **B**
- **30.6445.00** RB65 w/SWIVEL G1/2 F ——— **B**
- **30.6438.30** RB65 w/SWIVEL G1/2 F ——— **C**

- Low pressure gun with conical/pencil jet controlled by the trigger.
- Adjustable screw to vary cone width from 0° to 60°
- Covered by semi-housings of non-stainable shockproof plastic, entirely sealed and with 3 rubber protective rings.
- Plastic trigger protected by hand guard.
- Minimum fatigue for trigger opening and use.
- Internal structure in brass and Sst
- Ergonomic construction
- On request, inlet swivel connection.

TECHNICAL SPECIFICATIONS

P/N	FRAME COLOR	PISTON MATERIAL	SEALS MATERIAL	MAX FLOW RATE		RATED PRESSURE		(1) MAX TEMPERATURE CONTINUOUS USE		WEIGHT		INLET
				L/ min	USGpm	bar	MPa	°C	°F	g	lbs	
30.6400.00	Blue	Brass	Viton	60	15.8	24	2.4	60	140	925	2	G 1/2" F
30.6425.00	Blue	Brass	Viton	60	15.8	24	2.4	60	140	1045	2.3	Swivel G 1/2" F
30.6440.00	Blue	Brass	Viton	100	26.4	24	2.4	60	140	925	2	G 1/2" F
30.6445.00	Blue	Brass	Viton	100	26.4	24	2.4	60	140	1045	2.3	Swivel G 1/2" F
30.6438.30	Red	Sst	Viton	60	15.8	24	2.4	60	140	1045	2.3	Swivel G 1/2" F

(1) The gun has been designed for continuous use, at a water temperature of 60°C (140°F). It can resist at the max temperature of 90°C (195°F) for short periods only

Using the gun at a water temperature higher than 60°C involves for the operator the use of adequate safety devices, such as gloves, glasses, etc.

<p>Instruction manual, maintenance, installation, spare parts. <u>For a correct utilization, follow the directions of this manual</u> Re-print them on the Use and Maintenance booklet of the machine.</p>	<p>n. 12.9123.00</p>
--	----------------------

DIMENSIONAL DRAWING AND PRESSURE DROP CHART

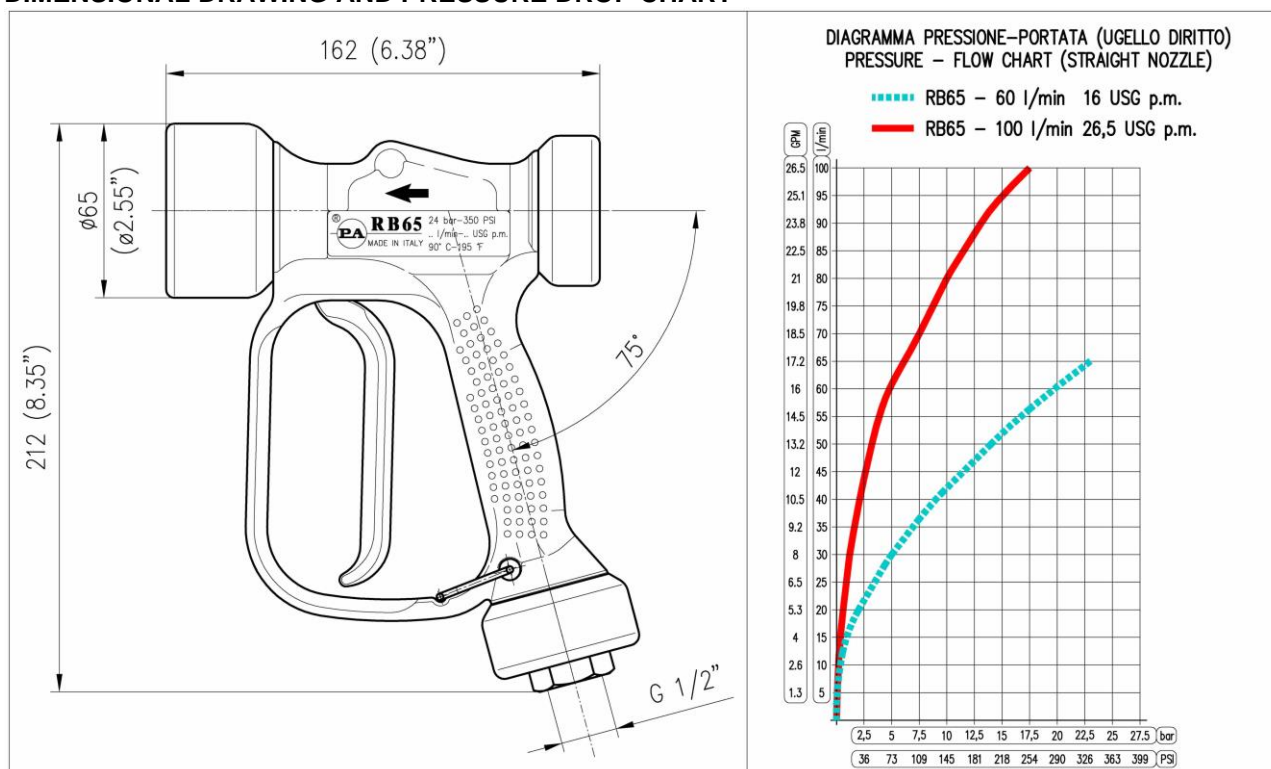

INSTRUCTIONS

This product is to be utilized with clean fresh water, even slightly additivated with normal detergents. For use involving different or corrosive liquids, contact the PA Technical department. Appropriate filtration should be installed when using unclean liquids. Choose the gun in line with the data of nominal running (system rated pressure, max flow and max temperature). In any case, the pressure of the machine should not exceed the permissible pressure rate imprinted on the gun.

INSTALLATION

This gun was designed to operate with **hot water** (in compliance with the technical specs). Provide the plant generating **hot water** with an equipment limiting the incidental increase of the fluid temperature.

Always fit a safety valve to protect the delivery conduct when the latter is under pressure.

Choose a suitable nozzle and adjust the valve mounted in the front of the gun, thus obtaining a constant supply and avoiding unpleasant pressure spike when closing the system.

If the nozzle wears out, the pressure falls. When you install a new nozzle, adjust the system back to the original pressure.

OPERATIONS

The gun opens and closes a high pressure conduct by means of a piston acting on a seat; the return is controlled by a spring which releases the trigger.

WATER HOSE FEED

By high or very unsteady pressure values on delivery, it is necessary to mount a pressure reducer, both to level the flow rate on delivery and to protect the system components.

PROBLEMS AND SOLUTIONS

PROBLEMS	PROBABLE CAUSES	SOLUTIONS
Leakage from the nozzle	Presence of impurities Gun seat worn out	Clean Replace seat Fit adequate filters and/or check
Leaking seals	Seals worn out	Replace seal
Difficult trigger opening	High pressure inside circuit	Control the bypass valve and adjust if necessary

Read this manual before starting the assembly.

For a correct utilization, follow the directions described in this manual and re-print them on the Use and maintenance manual of the machine.

The present manual is valid for all the guns named **RB65**.

SPARES

Use original PA spares only in order to get both a correct operation and a long lasting, reliable product.

MAINTENANCE

Maintenance has to be carried out by **Specialized Technicians**.

STANDARD: every 400 working hours (circa 10,000 cycles), check and lubricate the seals with water resistant grease.

SPECIAL: every 800 working hours(circa 20,000 cycles), check the wear of the seals and internal parts and if necessary, replace with original PA parts, taking care during installation to lubricate with water resistant grease.

CAUTION: re-assemble the gun restoring the original conditions.

The manufacturer is not to be considered responsible for damage as a result from incorrect fitting and maintenance.

Technical data, descriptions and illustrations are indicative and liable to modification without notice.

30.6400.00 RB65 spray gun,brass 1/2F Bsp adj.nzl
 30.6425.00 RB65 sp.gun,brass+sw.5 1/2F Bsp adj.nzl
 30.6430.00 Swivel, brass-13mm h.barb

30.6440.00 RB65 sp.gun, brass 1/2F adj.nozzle -100
 30.6445.00 RB65 sp.gun, brass+sw5 1/2F adjust.nozzle

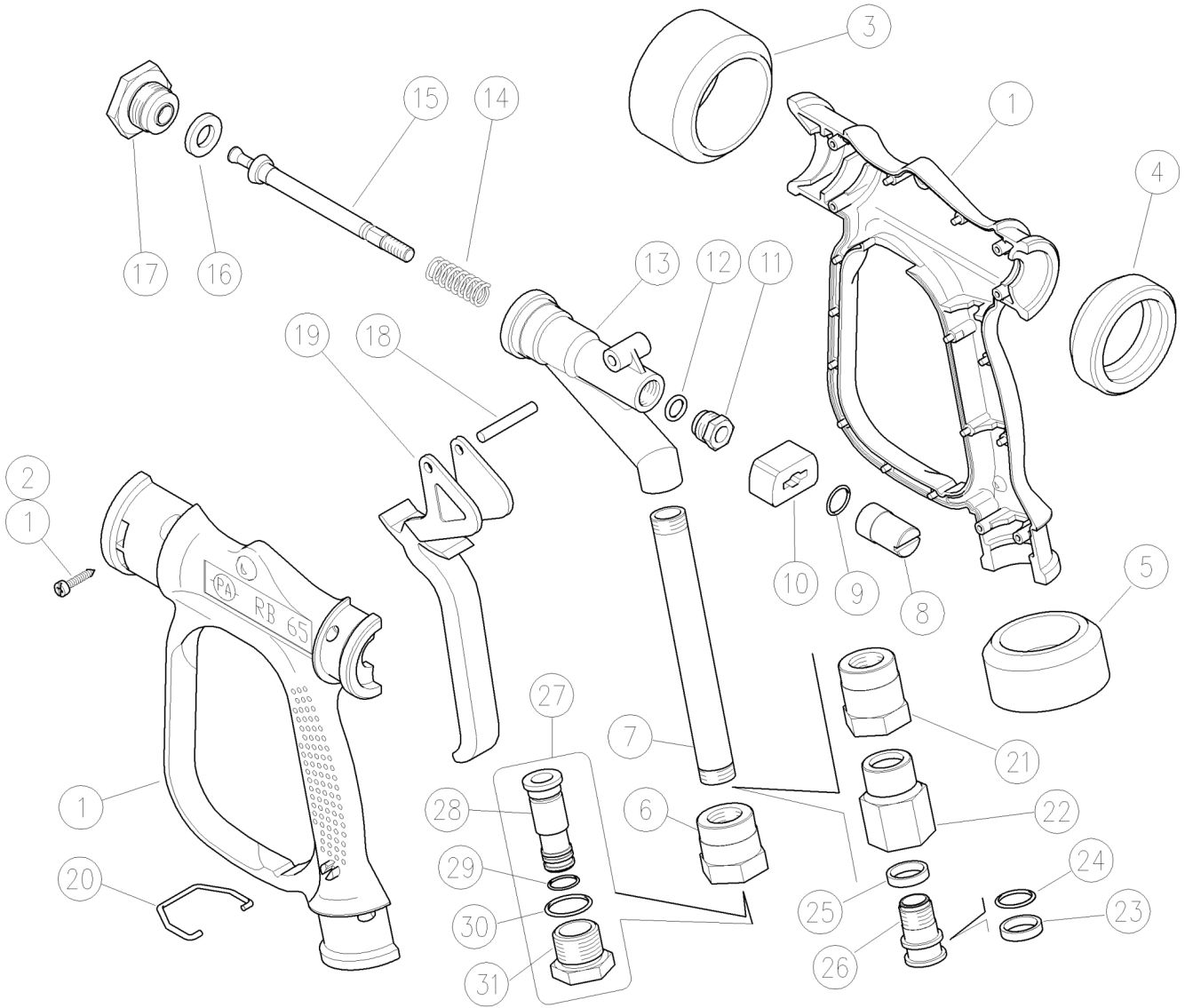

Pos.	P/N	Description	Q.ty	K1	K2	K3	K4
1	30.6420.24	Casing-kit -RB65-60L +screws, Sst. v.2 (1)	1				1
1	30.6446.24	Casing-kit -RB65-100L v.2+scr. Sst. (2)	1				1
2	16.3075.51R	S/tapping scr. 3,5x18 mm sst.	6				10
3	30.6412.85R	Front guard ring, TPEs blue v.2	1				5
4	30.6413.85R	Back guard ring, TPEs blue v.2	1				5
5	30.6414.85R	Lower guard ring, TPEs blue v.2	1				5
6	30.6407.31R	Coupl., M16x1,5F-1/2F Bsp brass (1)	1				5
7	30.6409.36R	Tube, M16x1,5 FF 130 mm brass	1				5
8	30.6418.31R	Regulating pin, M7	1				10
9	10.3064.10R	O-ring 1.78 x 14 mm Viton	1	•	•	•	10
10	30.6404.84R	Sliding block, PA blue (1)	1				10
10	30.6443.84R	Sliding block, PA red (2)	1				5
11	30.6417.31R	Plug, M14x1 M brass	1				10
12	10.3170.10R	O-ring, 2,62x7,6 mm Vi 70	1	•	•	•	10
13	30.6405.35R	Housing -RB65, brass	1				3
14	30.6454.51R	Spring, 2x12,9x40 mm Sst.	1	•	•		5
15	30.6406.31R	Piston -RB65, brass 60L/min (1)	1	•			5
15	30.6442.31R	Piston -RB65, brass 100L/min (2)	1		•		5

Pos.	P/N	Description	Q.ty	K1	K2	K3	K4
16	30.6408.85R	Front seal, 11x20,5x3 mm FKM80	1	•	•	•	10
17	30.6403.31R	Front Coupl. -RB65, brass 60L/min (1)	1				5
17	30.6441.31R	Front coupl. -RB65, brass 100L/min (2)	1				5
18	30.6428.31R	Parallel pin, 5x38 mm brass	1				10
19	30.6411.84R	Trigger -RB65, PA blue (1)	1				10
19	30.6444.84R	Trigger -RB65, PA red (2)	1				5
20	30.6415.51R	Trigger retainer, Sst.	1				5
21	30.6426.31R	Coupl. -SW, M15x1F-M16x1,5F (3)	1				3
22	30.6427.31R	Coupl. -SW, 1/2F Bsp (3)	1				5
23	26.1075.85R	Bushing, open 15,5x19x4mm (3)	1				10
24	10.3092.10R	O-ring, 2x15 mm Vi 70 (3)	1				10
25	26.1074.85R	Bushing, 15,5x19x4 mm PTFE (3)	1				10
26	26.1072.31R	Pin, M15x1-19 mm brass (3)	1				10
27	30.6430.00	Swivel, brass-13mm h.barb	1				10
28	30.6431.31R	13mm hose barb, brass	1				3
29	10.3060.00R	O-ring, 1,78x12,42 mm	1				10
30	10.3092.90R	O-ring, 2x19 mm	1				10
31	30.6432.31R	Coupl. -SW, 1/2M Bsp brass	1				3

Kit	P/N	Description	Q.ty
K1	30.6422.24	Seals spares kit -RB65, 3x1pcs.	1
K2	30.6423.24	Repair kit -RB65-60L, 5x1pcs.	1
K3	30.6424.24	Repair kit -RB65-100L, 5x1pcs.	1

(1) 30.6400.00 (2) 30.6440.00 (3) 30.6425.00