

**P.A. – S.p.A. – EQUIPAGGIAMENTI TECNICI DEL LAVAGGIO**

VIA MILANO, 13 – CASELLA POSTALE 115 – 42048 RUBIERA (REGGIO EMILIA) – ITALY  
 Tel. +39 0522 623611 – Fax. +39 0522 629600 – R.E.A. RE 156319 – R.I. RE11535 – Mecc. RE 013446  
 C.F. e P. IVA 01035950359 – Cap. Soc. i.v. € 750.000,00 – Codice Identificativo C.E.E. IT 01035950359  
 ART. 2497 – BIS C.C. DIREZIONE E COORDINAMENTO BENETTI srl R.I. TRIB. DI RE 01480690351  
 Web: <http://www.pa-etl.it> – E-mail: [info@pa-etl.it](mailto:info@pa-etl.it)



## RP30-80-120/160 – Pneumatic on-off guns

**Technical Manual: I 144**

Pneumatic on-off guns for pumps with permissible pressure up to 160 bar.

Pneumatic on-off guns prevent the passage of fluid if the compressed air supply is interrupted.



- **30.3280.00** RP 30-160 G 1/4" FF DN8
- **30.3260.00** RP 80-160 G 1/2" FF DN15
- **30.3200.00** RP 120-160 G 3/4" FF DN20

- Opening control with pneumatic piston.
- Reduced supply pressures for the pneumatic jack.
- Pneumatic piston and jacket in anodized aluminum.
- Seat and shutter pin in stainless steel.
- Reduced pressure losses
- Holes for fixing screws with a diameter of 6.5 mm.

### TECHNICAL SPECIFICATIONS

Construction material					Brass body and internal parts in stainless steel. Pneumatic jack in anodized aluminium.							
Rated temperature (1)					90°C							
PART NUMBER	RATED PRESSURE		PRESSIONE CONSENTITA		PERMISSIBLE PRESSURE		AIR MAX. PRESSURE		MAX. FLOW RATE	WEIGHT	WATER INLET OUTLET	AIR INLET
	bar	MPa	bar	MPa	bar	MPa	bar	MPa	l/min	g		
30.3280.00	160	16	175	17.5	7	0.7	10	1	30	560	G 1/4" F	G 1/4" F
30.3260.00	160	16	175	17.5	7	0.7	10	1	80	1080	G 1/2" F	G 1/2" F
30.3200.00	160	16	175	17.5	7	0.7	10	1	120	1890	G 3/4" F	G 1/4" F

- (1) Pneumatic on-off guns have been designed for continuous use at a water temperature of 60 ° C. They can resist for short periods at the maximum temperature of 90 ° C.

**Instruction manual, maintenance, installation, spare parts.**

n. 12.9144.00



- PNEUMATIC ON-OFF GUN RP120/160

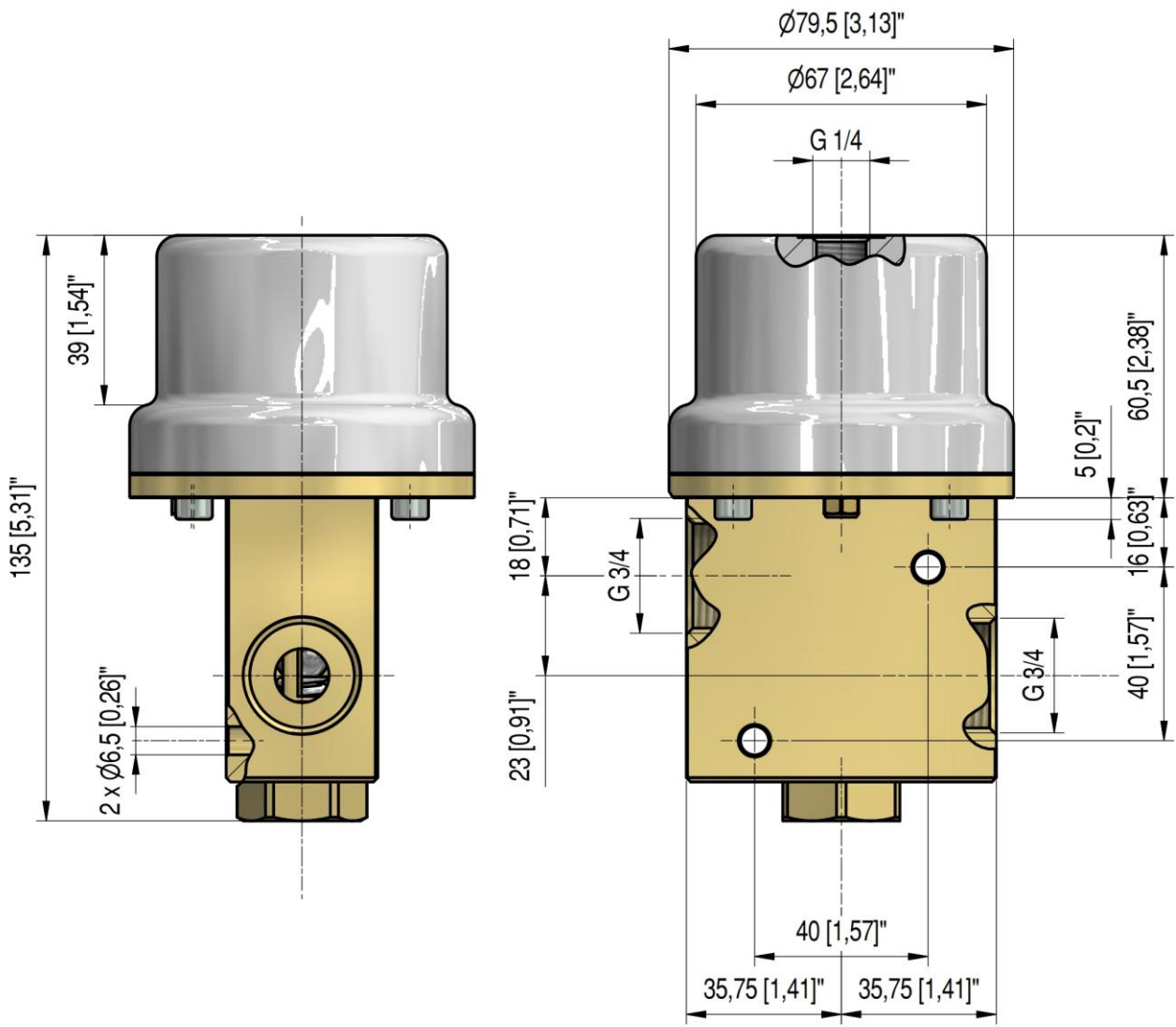

## DESCRIPTION

RP120 on-off gun features G3/4 "F threaded inlet and outlet for fluids.

RP30 on-off gun features G1/4 "F threaded inlet and outlet for fluids.

On-off guns are fitted with a pneumatic jack with a G 1/4 "F threaded feed hole is mounted on the taps.

## SELECTION

This product is suitable for use with clean fresh water or water with a **low percentage of commonly used detergents**. When using different or corrosive fluids, please consult our Technical Dept. When using non-pure fluids, provide for adequate filtration. Choose the Pneumatic On-Off Gun based on the operating data of the machine on which it is to be installed (rated operating pressure, maximum flow rate and maximum system temperature). In any case, no overpressure of the machine can exceed the rated pressure stamped on the body of the Pneumatic Gun.

## FUNCTION

The pneumatic gun opens and closes a high-pressure line by means of a piston acting on a seat;

the opening, i.e. the passage of the fluid, the tap opens and closes a high-pressure duct by means of a piston which acts on a seat;

the opening, therefore the passage of the fluid, occurs by means of a pneumatic jack which, by pushing on the shutter piston, will free the seat, the return is spring-loaded, therefore, by interrupting the air supply, the shutter piston will occlude the seat and consequently to interrupt the passage of the fluid. by means of a pneumatic jack which, by pushing on the shutter piston, will free the seat, the return is spring-loaded, therefore, by interrupting the air supply, the shutter piston will occlude the seat and consequently interrupt the passage of the fluid.

## WATER SUPPLY PIPE

With high or highly variable supply pressures, it is necessary to install a pressure reducer, both to standardize the supply flow rate and to protect the system components.

## INSTALLATION

This pneumatic on-off gun can be used with **hot water** (as per technical specifications).

In systems generating **hot water**, install devices that prevent accidental increase of the fluid temperature.

**Always** install a safety valve to protect the delivery line when this remains under pressure.

Choose the appropriate nozzle and adjust the valve, mounted upstream of pneumatic on-off gun, so as to obtain constant delivery value and avoid annoying pressure spikes when the system is closed.

If the nozzle wears out, the working pressure decreases. To restore the working pressure, replace the worn nozzle.

When a new nozzle is installed, the system must be re-calibrated at the original working pressure.

The pneumatic jack must be fed with **dry and lubricated air** at a maximum pressure of 10 bar.

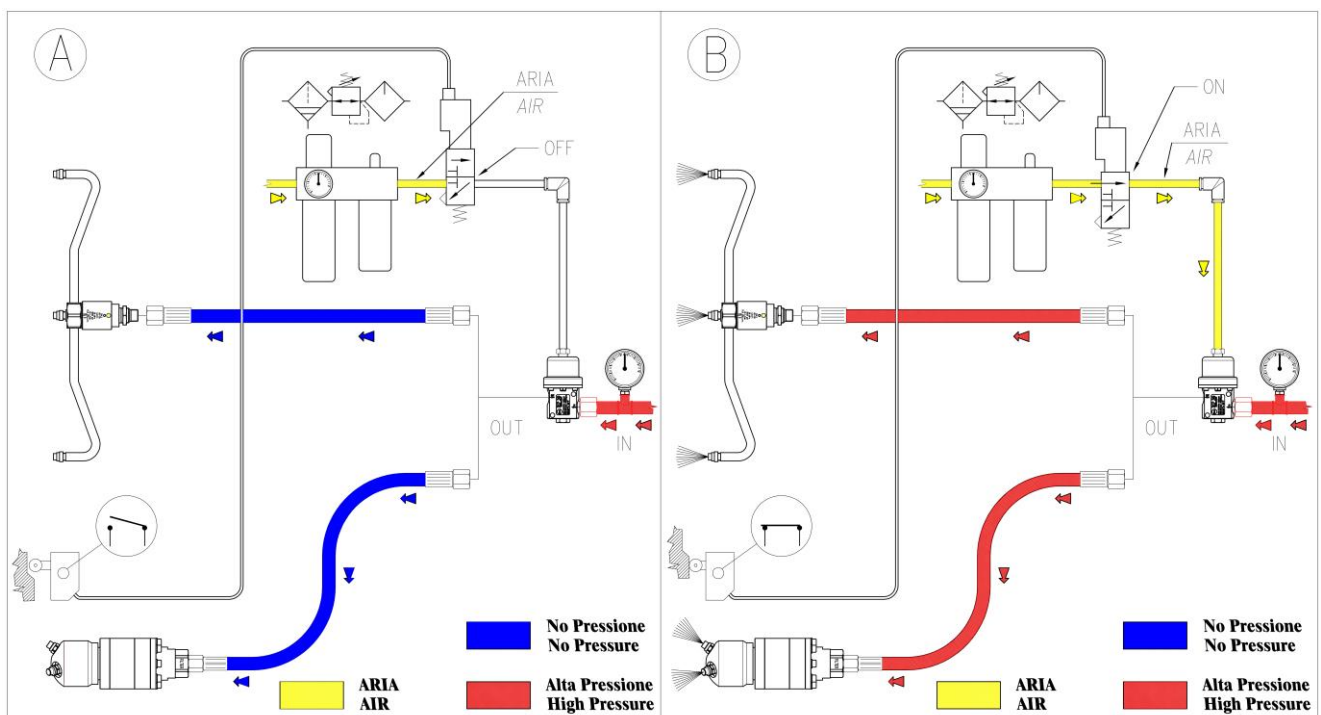

**TROUBLESHOOTING**

PROBLEMS	PROBABLE CAUSES	SOLUTIONS
Leakage on the nozzle side	Presence of impurities Worn out seat	Clean Replace seat and piston Install adequate filters and/or check
Seals leakage	Worn out seals	Replace seals

**MAINTENANCE**

ORDINARY: every 400 working hours, check and lubricate the seals with water-resistant grease.

EXTRAORDINARY: every 800 working hours, check the wear of seals and internal components, if necessary, replace them with original PA spare parts, taking care during assembly, to lubricate with water-resistant grease.

Maintenance has to be carried out by specialized technicians,

**The manufacturer shall not be considered responsible for damages resulting from incorrect installation and maintenance.**

**REGULATIONS:** see Norm Manual

For correct installation and use, follow the directions described in this manual and re-print them in the Use and Maintenance Manual of the machine which incorporates this product.

Make sure you are given the Original Conformity Declaration for the accessory chosen. This manual is valid for all pneumatic on-off guns named **RP30-160**, **RP80-160** and **RP120-160**.

Technical data, descriptions and illustrations are indicative and liable to modification without notice.

### 30.3280.00 RP30 1/4FF Bsp air compr.on-off gun

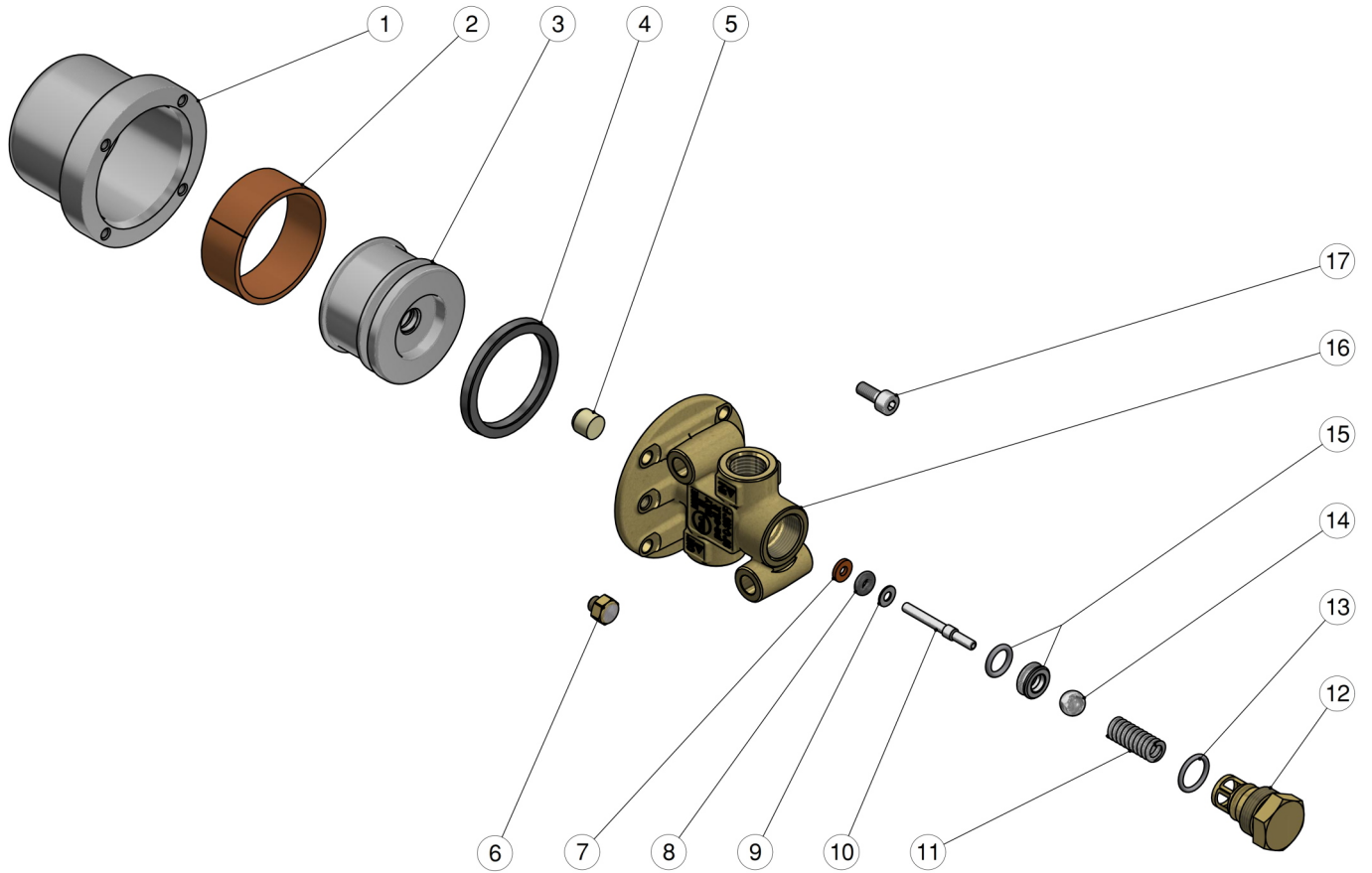

Pos.	P/N	Description	Q.ty	K1	K2	K3	K4		Pos.	P/N	Description	Q.ty	K1	K2	K3	K4	
1	30.3283.41R	Jacket, Al -RP30	1					3	10	30.0704.51R	Piston, 3-4 mm Sst.	1					10
2	30.3285.85R	Bushing, opn. 118x14,8mm PTFE	1					5	11	30.3284.51R	Spring, 1,3x6,3x23 mm Sst.	1					10
3	30.3281.41R	Piston, RP30	1					2	12	30.2595.31R	Spring plug, M16x1 brass	1					10
4	10.2041.32R	Piston seal, 40x32x3,25 mm	1					3	13	10.3020.02R	O-ring, 1,5x10 mm Ni 85	1					10
5	30.0675.84R	Stop pin, 8x7,1mm PA	1					10	14	14.7448.00R	Ball, 5/16" Sst.	1					10
6	13.0805.00R	Screw M5 brass	1					3	15	30.1708.20R	Seat, 6mm Sst.+O-ring	1					10
7	10.4018.00R	Back-up ring, 3,2x7,5x1,2 mm	1					10	16	30.3282.35R	Brass hous.-RP30-1/4"Bsp FF	1					2
8	10.3165.00R	O-ring, 2,62x2,84 mm Vi 70	1					10	17	16.1834.00R	Z.pl.screw M4x10 mm	4					10
9	14.3511.00R	Washer, 3,2x7x0,5 mm sst.	1					10									

30.3260.00 RP80/160 -1/2 FF Bsp air compr.on-off gun

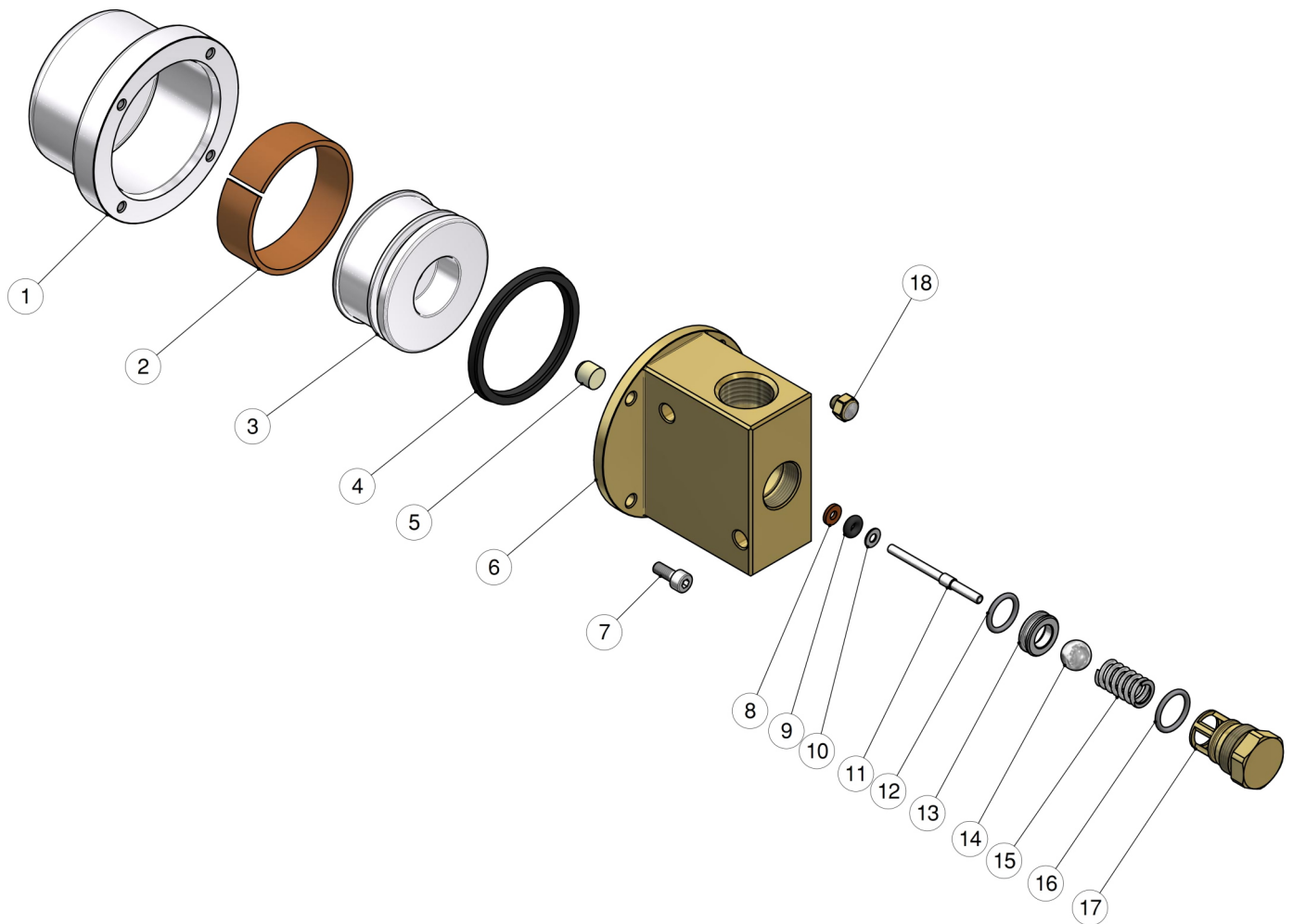

Pos.	P/N	Description	Q.ty	K1	K2	K3	K4
1	30.3264.41R	Jacket, Al -RP80/160	1				3
2	30.3263.85R	Bushing, opn. 148,5x14,8mm PTFE	1				5
3	30.3262.41R	Piston, RP 80/160	1				2
4	10.2051.42R	Piston seal, 50x42x3,5 mm	1				3
5	30.0675.84R	Stop pin, 8x7,1mm PA	1				10
6	30.3261.31R	Brass hous.-RP80/160-1/2 Bsp FF	1				1
7	16.1834.00R	Z.pl.screw M4x10 mm	4				10
8	10.4018.00R	Back-up ring, 3,2x7,5x1,2 mm	1				10
9	10.3165.00R	O-ring, 2,62x2,84 mm Vi 70	1				10

Pos.	P/N	Description	Q.ty	K1	K2	K3	K4
10	14.3511.00R	Washer, 3,2x7x0,5 mm sst.	1				10
11	30.2802.51R	Sst.plunger D.4x3x L.43mm	1				10
12	10.3059.01R	O-ring, 1,78x11,11 mm Ni 85	1				10
13	30.2806.20R	Seat, 9mm Sst.+O-ring	1				10
14	14.7461.00R	Ball, 13/32" Sst.	1				10
15	30.4108.51R	Spring, 1,6x8,8x24 mm Sst.	1				10
16	10.3060.10R	O-ring, 1,78x12,42 mm Vi 70	1				10
17	30.2803.31R	Spring plug M18 brass	1				5
18	13.0805.00R	Screw M5 brass	1				3

### 30.3200.00 RP120 3/4FF Bsp air compr.on-off gun

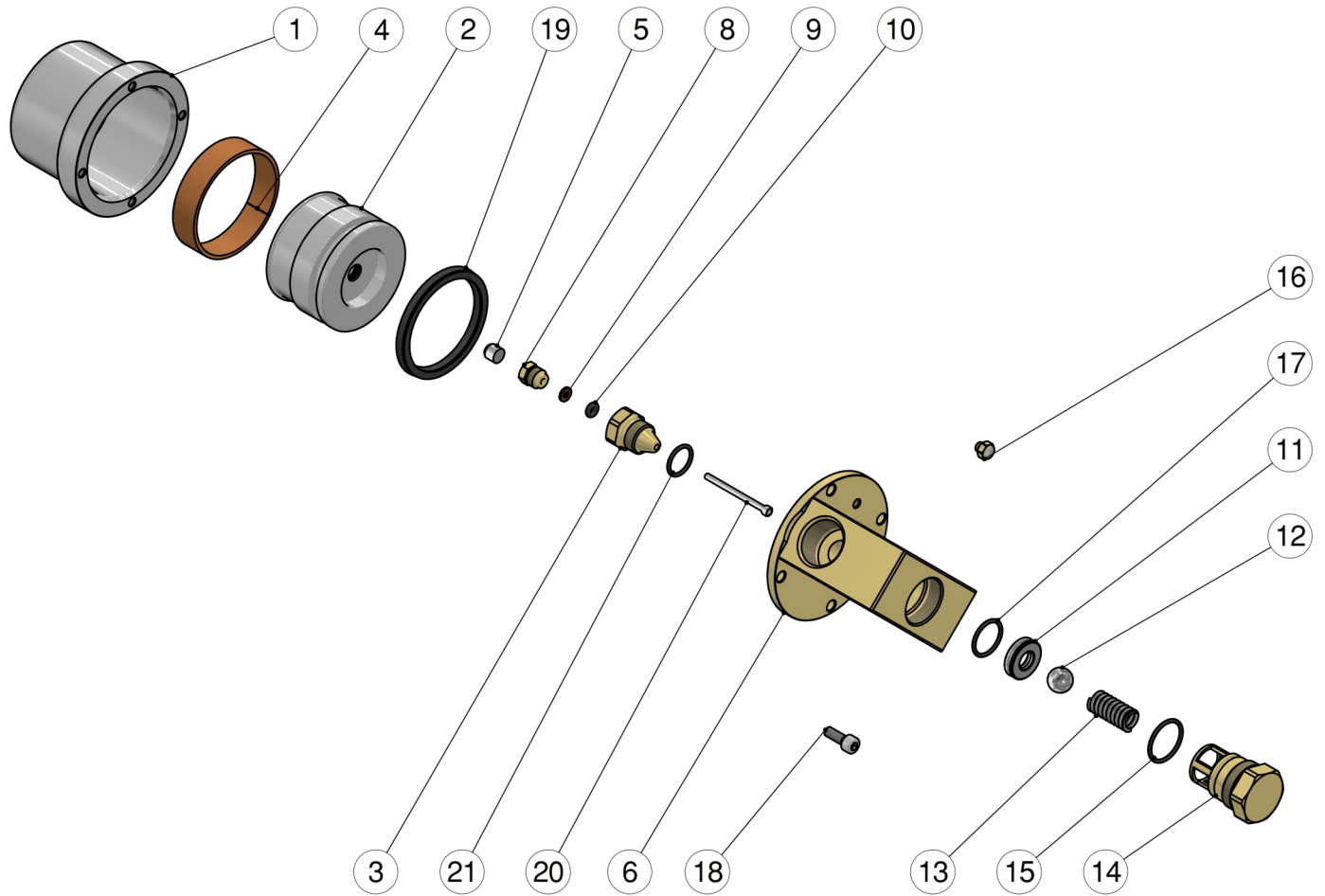

Pos.	P/N	Description	Q.ty	K1	K2	K3	K4		Pos.	P/N	Description	Q.ty	K1	K2	K3	K4	
1	30.3206.41R	Jacket, Al -RP120	1					3	12	14.7465.00R	Ball, 1/2" Sst.	1					5
2	30.3207.41R	Piston, RP120	1					2	13	30.5304.51R	Spring, 2x29x9,9 mm Sst.	1					10
3	30.3203.31R	Plug, M16x1 brass	1					5	14	30.3205.31R	Spring plug, M26x1 brass	1					2
4	30.3204.85R	Bushing, opn. 181x14,8mm PTFE	1					5	15	10.3072.01R	O-ring, 1,78x20,35 mm Ni 85	1					10
5	30.0675.51R	Stop pin, 8x7,1mm Sst.	1					10	16	13.0805.00R	Screw M5 brass	1					3
6	30.3201.31R	Brass hous.-RP120-3/4\"/>															