

TMMD

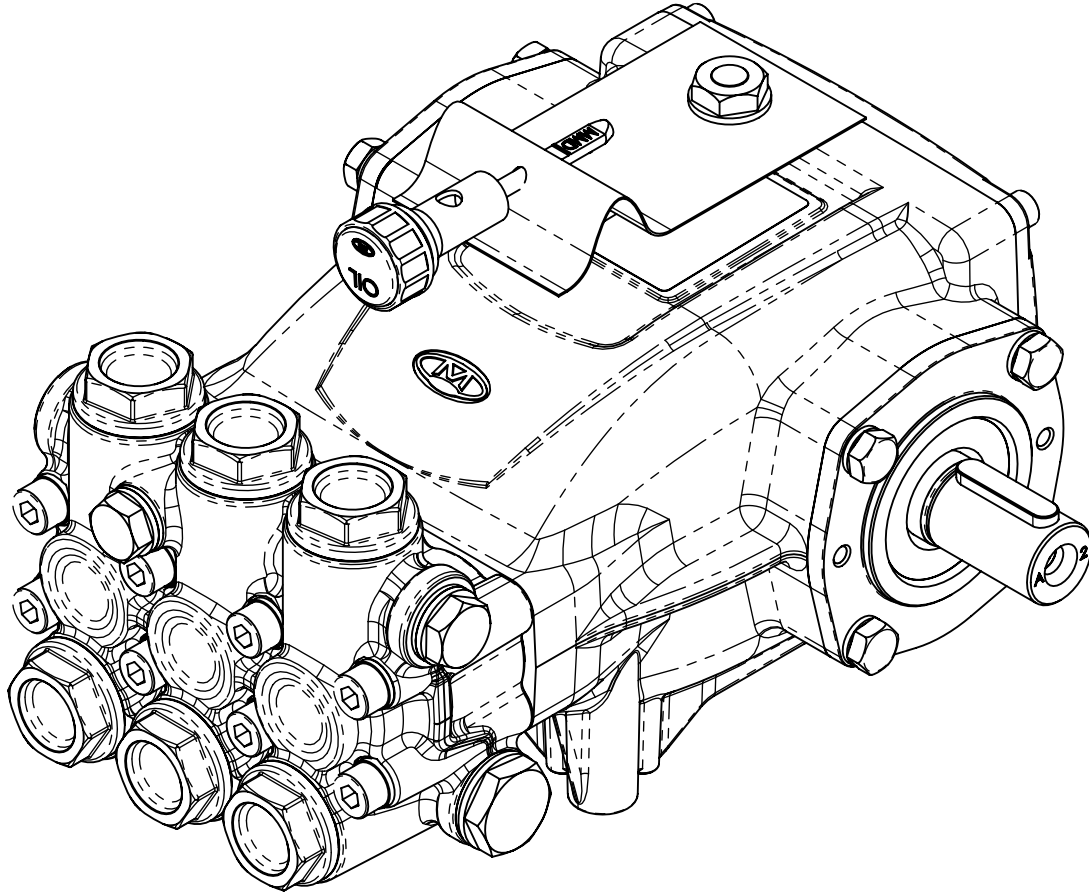

General table

Model	Pressure (Bar)	Pressure (Psi)	Flow Rate 1450 rpm (Lit/min)	Flow Rate 1740 rpm (Lit/min)	Flow Rate 1450 rpm (gpm)	Flow Rate 1740 rpm (gpm)	Round 50Hz (RPM)	Round 60Hz (RPM)	Power 50Hz (Hp)	Power 50Hz (Kw)	Power 60Hz (Hp)	Power 60Hz (Kw)
TMMD12200 (R-L)	200	2900.75	12.00	14.40	3.17	3.80	1450	1740	6.23	4.65	7.48	5.58
TMMD15200 (R-L)	200	2900.75	15.00	18.00	3.96	4.75	1450	1740	7.79	5.82	9.35	6.98
TMMD18200 (R-L)	200	2900.75	18.00	21.60	4.75	5.71	1450	1740	9.35	6.98	11.22	8.37
TMMD21200 (R-L)	200	2900.75	21.00	25.20	5.55	6.66	1450	1740	10.91	8.14	8.37	9.77

Model	Pressure (Bar)	Pressure (Psi)	Flow Rate 1000 rpm (Lit/min)	Flow Rate 1200 rpm (Lit/min)	Flow Rate 1000 rpm (gpm)	Flow Rate 1200 rpm (gpm)	Round 50Hz (RPM)	Round 60Hz (RPM)	Power 50Hz (Hp)	Power 50Hz (Kw)	Power 60Hz (Hp)	Power 60Hz (Kw)
TMMD15250 (R-L)	200	2900.75	15.00	18.00	3.96	4.75	1000	1200	7.79	5.82	9.35	6.98

Exploded TMMD

Espoloso TMMD

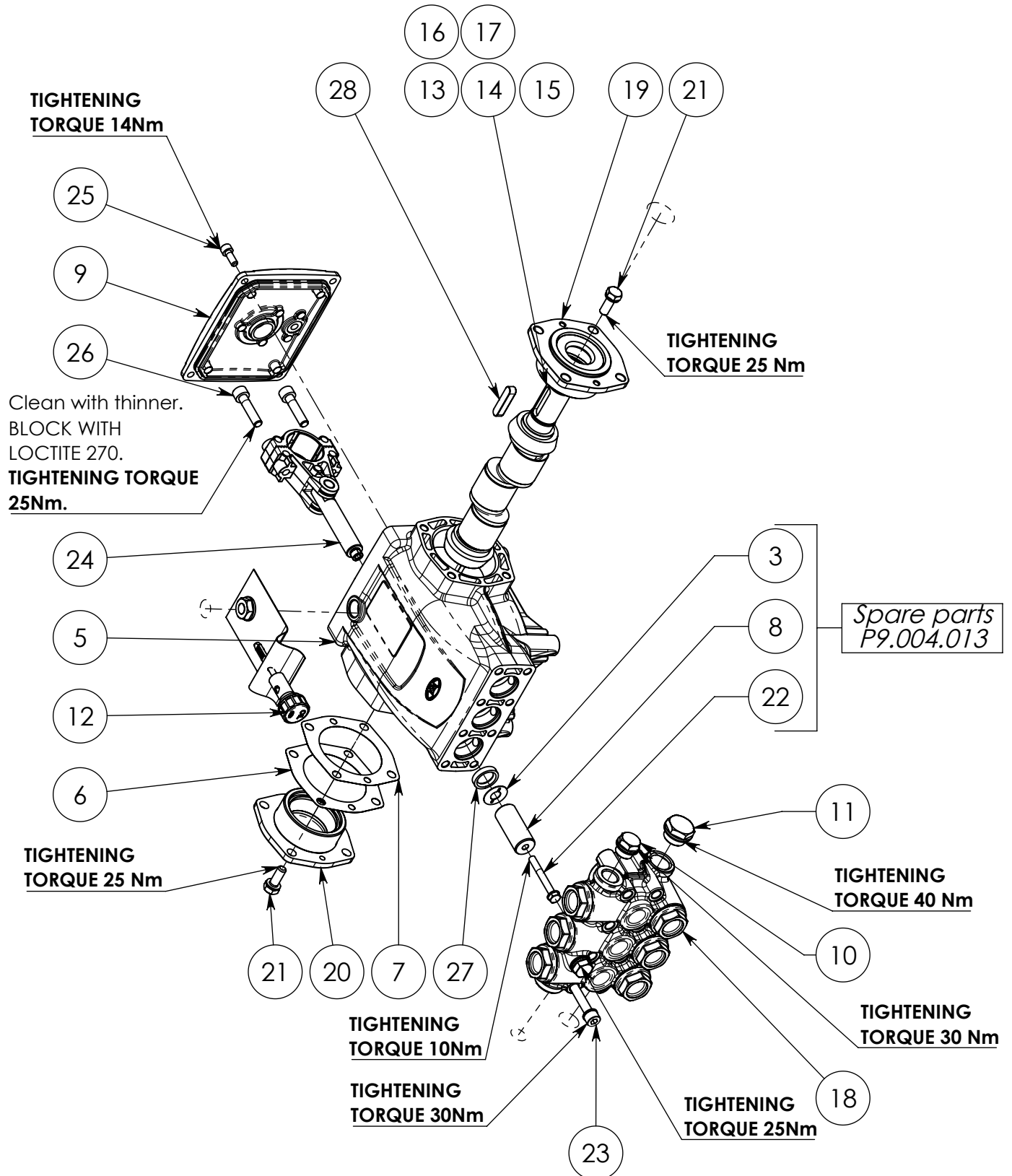



Pos.						Code	ITALIANO	ENGLISH	DEUTSCH	ESPAÑOL	FRANCAIS
	TMMD 12250 (R-L) Q.TY	TMMD 15250 (R-L) Q.TY	TMMD 18250 (R-L) Q.TY	TMMD 21250 (R-L) Q.TY	TMMD 15250 (R-L) 1000rpm Q.TY						
2	1	1	1	1	1	P0.020.003	Olio o Lubrificante HYDRAULIC 0.7 LIT	Oil or Lubricants HYDRAULIC 0.7 LIT	Öl oder Schmierstoffe HYDRAULIC 0.7 LIT	Aceite o lubricante HYDRAULIC 0.7 LIT	ÖlHuile ou lubrifiant HYDRAULIC 0.7 LIT
3	3	3	3	3	3	P1.003.003	Rondella Rame ø23.5 ø9.6X0.5	Copper washer ø23.5 ø9.6X0.5	Kupferunterlegsscheibe ø23.5 ø9.6X0.5	Arandela de cobre ø23.5 ø9.6X0.5	Rondelle cuivre ø23.5 ø9.6X0.5
4	1	1	1	1	1	P1.012.052	Tappo	Cap	Deckel	Tapón	Bouchon
5	1	1	1	1	1	P1.020.006	Corpo Pompa MM-2	Pump Body MM-2	Pumpenkörper MM-2	Cuerpo de la bomba MM-2	Corps de pompe MM-2
6	1	1	1	1	1	P1.060.007	Distanziale MM-2" Sp.0.19	Spacer MM-2" Sp.0.19	Distanzstueck MM-2" Sp.0.19	Distanciador MM-2" Sp.0.19	Entretoise MM-2" Sp.0.19
7	1	1	1	1	1	P1.060.008	Distanziale "MM-2" Sp.0.05	Spacer "MM-2" Sp.0.05	Distanzstueck "MM-2" Sp.0.05	Distanciador "MM-2" Sp.0.05	Entretoise "MM-2" Sp.0.05
8	3	3	3	3	3	P1.071.013	Pistone ø20 h46-MM-2	Piston ø20 h46-MM-2	Kolben ø20 h46-MM-2	Pistón ø20 h46-MM-2	Piston ø20 h46-MM-2
9	1	1	1	1	1	P2.012.001	Coperchio MMD	Cover MMD	Deckel MMD	Tapa MMD	Couvercle MMD
10	1	1	1	1	1	P2.013.023	Tappo 3/8" GAS	Cap 3/8" GAS	Deckel 3/8" GAS	Tapón 3/8" GAS	Bouchon 3/8" GAS
11	1	1	1	1	1	P2.013.024	Tappo 1/2" GAS	Cap 1/2" GAS	Deckel 1/2" GAS	Tapón 1/2" GAS	Bouchon 1/2" GAS
12	1	1	1	1	1	P2.013.037	Tappo MMD GM XM	Cap MMD GM XM	Deckel MMD GM XM	Tapón MMD GM XM	Bouchon MMD GM XM
13	1	-	-	-	-	P2.014.011	Albero -E-MM-2	Shaft -E-MM-2	Welle -E-MM-2	Eje -E-MM-2	Arbre -E-MM-2
14	-	1	-	-	-	P2.014.012	Albero -A-MM-2	Shaft -A-MM-2	Welle -A-MM-2	Eje -A-MM-2	Arbre -A-MM-2
15	-	-	1	-	-	P2.014.013	Albero -B-MM-2	Shaft -B-MM-2	Welle -B-MM-2	Eje -B-MM-2	Arbre -B-MM-2
16	-	-	-	1	-	P2.014.014	Albero -C-MM-2	Shaft -C-MM-2	Welle -C-MM-2	Eje -C-MM-2	Arbre-C-MM-2
17	-	-	-	-	1	P2.014.015	Albero -D-MM-2	Shaft -D-MM-2	Welle -D-MM-2	Eje -D-MM-2	Arbre -D-MM-2
18	1	1	1	1	1	P2.035.019	Testata pompa TMMD	Pump head TMMD	Pumpekopf TMMD	Cabeza bomba TMMD	Tete de pompe TMMD
19	1	1	1	1	1	P2.060.005	Flangia P.d.F. MMD	Flange P.T.O. MMD	Flansch PTO MMD	Brida toma de fuerza MMD	Bride prise de force MMD
20	1	1	1	1	1	P2.060.006	Flangia MMD	Flange MMD	Flansch MMD	Borde MMD	Bride MMD
21	8	8	8	8	8	P2.119.002	Vite M8X22	Screw M8X22	Schrauben M8X22	Tornillo M8X22	Vis M8X22
22	3	3	3	3	3	P2.119.003	Vite M6X50	Screw M6X50	Schrauben M6X50	Tornillo M6X50	Vis M6X50
23	8	8	8	8	8	P2.119.007	Vite M8X70	Screw M8X70	Schrauben M8X70	Tornillo M8X70	Vis M8X70
24	3	3	3	3	3	P2.150.006	Biella MMD	Connecting rod MMD	Plenelstange MMD	Biela MMD	Bielle MMD
25	4	4	4	4	4	P4.002.004	Vite M6x16 UNI5931	Screw M6x16 UNI5931	Schrauben M6x16 UNI5931	Tornillo M6x16 UNI5931	Vis M6x16 UNI5931
26	6	6	6	6	6	P4.002.016	Vite M8x35 UNI5931-67	Screw M8x35 UNI5931-67	Schrauben M8x35 UNI5931-67	Tornillo M8x35 UNI5931-67	Vis M8x35 UNI5931-67
27	3	3	3	3	3	P4.015.002	Anello 16x24x5 NBR	Ring 16x24x5 NBR	Ring 16x24x5 NBR	Anillo 16x24x5 NBR	Bague 16x24x5 NBR
28	1	1	1	1	1	P4.021.001	Chiavetta 8x7x35	Key 8x7x35	Keil 8x7x35	Chaveta 8x7x35	Clavette 8x7x35

TMMD Drawing

Disegno TMMD

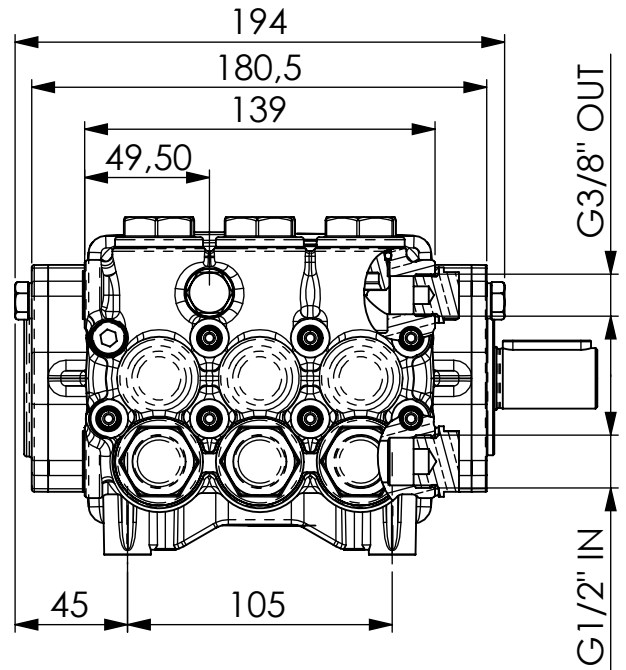
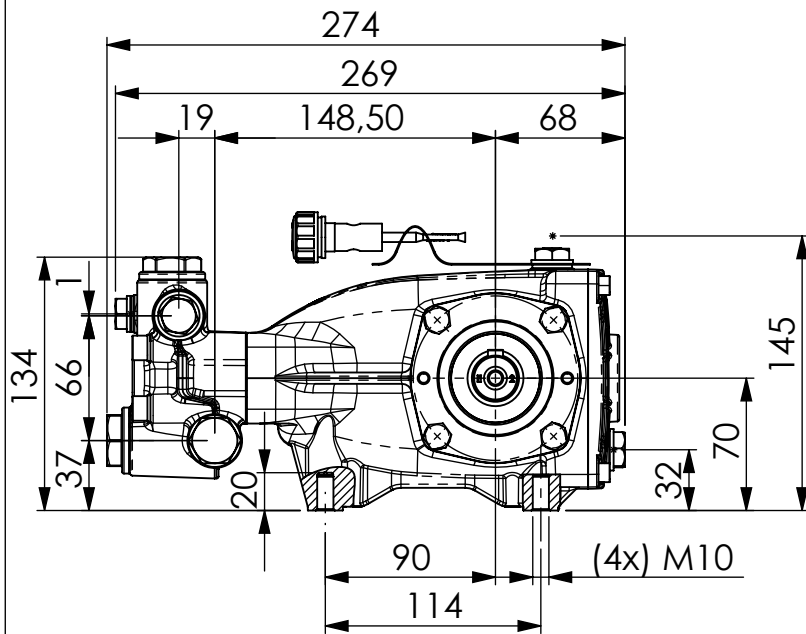

Detailed flange view
Vista dettagliata flangia

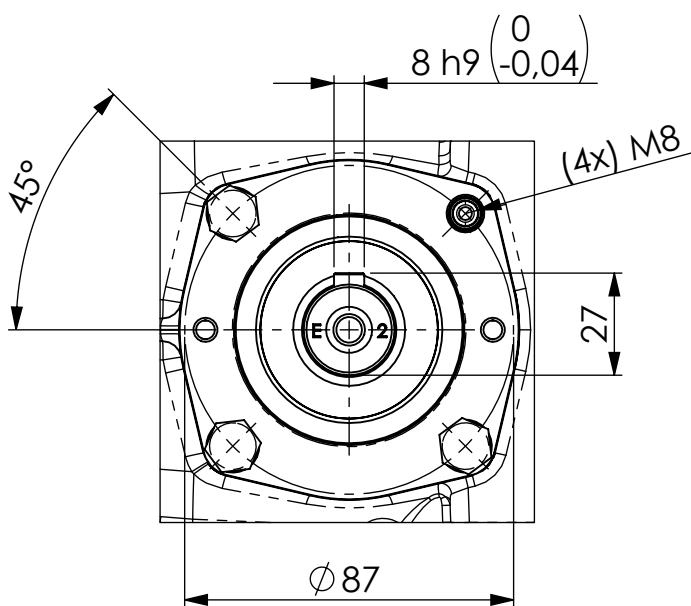

Detailed shaft view
Vista dettagliata albero

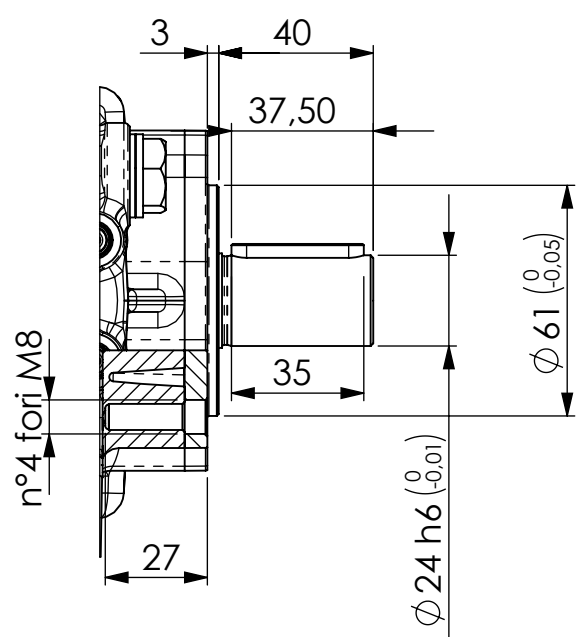

Spare Parts Ricambi

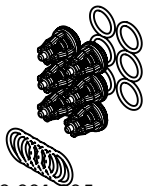

Code	Q.ty	ITALIANO	ENGLISH	DEUTSCH	ESPAÑOL	FRANCAIS
P2.003.006	6	Valvola VAM 21L/min ø21 MM-1	Valve VAM 21L/min ø21 MM-1	Ventil VAM 21L/min ø21 MM-1	Válvula VAM 21L/min ø21 MM-1	Valve VAM 21L/min ø21 MM-1
P4.005.001	6	OR 3068 NBR	O-ring 3068 NBR	O-Ring 3068 NBR	OR 3068 NBR	Joint torique 3068 NBR
P4.005.002	6	OR 2.62x20.29	O-ring 2.62x20.29	O-Ring 2.62x20.29	OR 2.62x20.29	Joint torique 2.62x20.29

P9.001.005
KIT VALVOLA COMPLETA POMPA MMD - KIT VALVES FOR MM PUMP



Code	Q.Ty	ITALIANO	ENGLISH	DEUTSCH	ESPAÑOL	FRANCAIS
P4.005.029	3	Guarnizione OR 2118 NBR-1.78x29.87	Gasket OR 2118 NBR-1.78x29.87	Dichtung OR 2118 NBR-1.78x29.87	Guarnición OR 2118 NBR-1.78x29.87	Garniture OR 2118 NBR-1.78x29.87
P4.100.015	3	Tenuta pistone posteriore HT ø20	Piston seal back HT ø20	Kolbendichtung zurück HT ø20	Piston sellado posterior HT ø20	Piston joint arrière HT ø20
P4.100.016	3	Tenuta pistone anteriore HT ø20	Front piston seal HT ø20	Front Kolbendichtung HT ø20	Junta del pistón delantero HT ø20	Joint de piston avant HT ø20

P9.003.017
GUARNIZIONE PISTONE ø20 POMPA MMD HT - KIT PLUNGER SEALS ø20 FOR MM PUMP



Code	Q.Ty	ITALIANO	ENGLISH	DEUTSCH	ESPAÑOL	FRANCAIS
P4.100.016	1	Tenuta pistone anteriore HT ø20	Front piston seal HT ø20	Front Kolbendichtung HT ø20	Junta del pistón delantero HT ø20	Joint de piston avant HT ø20
P1.024.018	1	Diffusore MM-2 HT	Diffusor MM-2 HT	Diffusor MM-2 HT	Difusor MM-2 HT	Diffuseur MM-2 HT
P2.118.004	1	Pressore MM-2 HT	Pressure Ring MM-2 HT	Bague de pression MM-2 HT	Anillo de presión MM-2 HT	Bague de pression MM-2 HT

P9.003.027
GUARN. PISTONE ø20 POMPA MMD PACCO COMPLETO (HT) - KIT COMPLETE SEALS

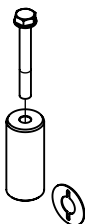

Code	Q.ty	ITALIANO	ENGLISH	DEUTSCH	ESPAÑOL	FRANCAIS
P1.003.003	1	Rondella Rame ø23.5 ø9.6X0.5	Copper washer ø23.5 ø9.6X0.5	Kupferunterlegscheibe ø23.5 ø9.6X0.5	Arandela de cobre ø23.5 ø9.6X0.5	Rondelle cuivre ø23.5 ø9.6X0.5
P1.071.013	1	Pistone ø20 h46-MM-2	Piston ø20 h46-MM-2	Kolben ø20 h46-MM-2	Pistón ø20 h46-MM-2	Piston ø20 h46-MM-2
P2.119.003	1	Vite M6X50	Screw M6X50	Schrauben M6X50	Tornillo M6X50	Vis M6X50

P9.004.013
KIT PISTONE ø20 POMPA MMD - KIT CERAMIC PISTON



Code	Q.ty	ITALIANO	ENGLISH	DEUTSCH	ESPAÑOL	FRANCAIS
P4.015.002	3	Anello 16x24x5 NBR	Ring 16x24x5 NBR	Ring 16x24x5 NBR	Anillo 16x24x5 NBR	Bague 16x24x5 NBR

P9.039.001
ANELLI TENUTA OLIO ASTA POMPA MM-PM - KIT OIL SEALS

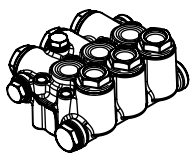

Code	Q.Ty	ITALIANO	ENGLISH	DEUTSCH	ESPAÑOL	FRANCAIS
P2.013.023	1	Tappo 3/8" GAS	Cap 3/8" GAS	Deckel 3/8" GAS	Tapón 3/8" GAS	Bouchon 3/8" GAS
P2.013.024	1	Tappo 1/2" GAS	Cap 1/2" GAS	Deckel 1/2" GAS	Tapón 1/2" GAS	Bouchon 1/2" GAS
P2.035.019	1	Testata pompa TMMD	Pump head TMMD	Pumpekopf TMMD	Cabeza bomba TMMD	Tete de pompe TMMD
P4.043.001	1	Protezione ø20	Protection ø20	Schutz ø20	Protección ø20	Protection ø20
P4.043.002	1	Protezione 15.5	Protection 15.5	Schutz 15.5	Protección 15.5	Protection 15.5

P9.040.019
KIT TESTATA COMPLETA PISTONE ø20 POMPA MMD HT - COMPLETE HEAD OF THE PUMP

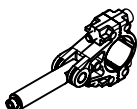

Code	Q.ty	ITALIANO	ENGLISH	DEUTSCH	ESPAÑOL	FRANCAIS
P2.150.006	1	Biella MMD	Connecting rod MMD	Plenelstange MMD	Biela MMD	Bielle MMD
P4.002.016	2	Vite M8x35 UNI5931-67	Screw M8x35 UNI5931-67	Schrauben M8x35 UNI5931-67	Tornillo M8x35 UNI5931-67	Vis M8x35 UNI5931-67

P9.041.004
BIELLA -ASTA POMPA MMD - PREASSEMBLED CONNECTING ROD

Pump head TMMD

Testata pompa TMMD



Use LOCTITE 270.
**TIGHTENING TORQUE
40Nm.**

*Spare parts
P9.003.017*

*Spare parts
P9.001.005*

**TIGHTENING
TORQUE 25Nm**

*Spare parts
P9.003.027*

Use LOCTITE 270.
**TIGHTENING TORQUE
40Nm.**

*Spare parts
P9.001.005*

P2.035.019.D

Spare parts P9.040.019

Pos.	Q.Ty	Code	ITALIANO	ENGLISH	DEUTSCH	ESPAÑOL	FRANCAIS
1	1	P1.012.017	Tappo G 1/4 H18	Cap G 1/4 H18	Deckel G 1/4 H18	Tapón G 1/4 H18	Bouchon G 1/4 H18
2	3	P1.024.018	Diffusore MM-2 HT	Diffusor MM-2 HT	Diffusor MM-2 HT	Difusor MM-2 HT	Diffuseur MM-2 HT
3	1	P1.043.015	Testata pompa TMMD	Pump head TMMD	Pumpekopf TMMD	Cabeza bomba TMMD	Tete de pompe TMMD
4	6	P2.003.006	Valvola VAM 21L/min ø21 MM-1	Valve VAM 21L/min ø21 MM-1	Ventil VAM 21L/min ø21 MM-1	Válvula VAM 21L/min ø21 MM-1	Valve VAM 21L/min ø21 MM-1
5	6	P2.013.010	Tappo VAM M24X1.5 + OR MM-2 HT	Cap VAM M24X1.5 + OR MM-2 HT	Deckel VAM M24X1.5 + OR MM-2 HT	Tapón VAM M24X1.5 + OR MM-2 HT	Bouchon VAM M24X1.5 + OR MM-2 HT
6	3	P2.118.004	Pressore MM-2 HT	Pressure Ring MM-2 HT	Bague de pression MM-2 HT	Anillo de presión MM-2 HT	Bague de pression MM-2 HT
6.1	1	P4.100.015	Tenuta pistone posteriore HT ø20	Piston seal back HT ø20	Kolbendichtung zurück HT ø20	Piston sellado posterior HT ø20	Piston joint arrière HT ø20
6.2	1	P4.005.029	Guarnizione OR 2118 NBR-1.78x29.87	Gasket OR 2118 NBR-1.78x29.87	Dichtung OR 2118 NBR-1.78x29.87	Guarnición OR 2118 NBR-1.78x29.87	Garniture OR 2118 NBR-1.78x29.87
7	6	P4.005.001	OR 3068 NBR	O-ring 3068 NBR	O-Ring 3068 NBR	OR 3068 NBR	Joint torique 3068 NBR
8	1	P4.008.007	Rondella Rame 1/4 Ø13x19x1.5	Copper washer 1/4 Ø13x19x1.5	Kupferunterlegsscheibe 1/4 Ø13x19x1.5	Arandela de cobre 1/4 Ø13x19x1.5	Rondelle cuivre 1/4 Ø13x19x1.5
9	3	P4.100.016	Tenuta pistone anteriore HT ø20	Front piston seal HT ø20	Front Kolbendichtung HT ø20	Junta del pistón delantero HT ø20	Joint de piston avant HT ø20

Connecting rod MMD

Biella MMD

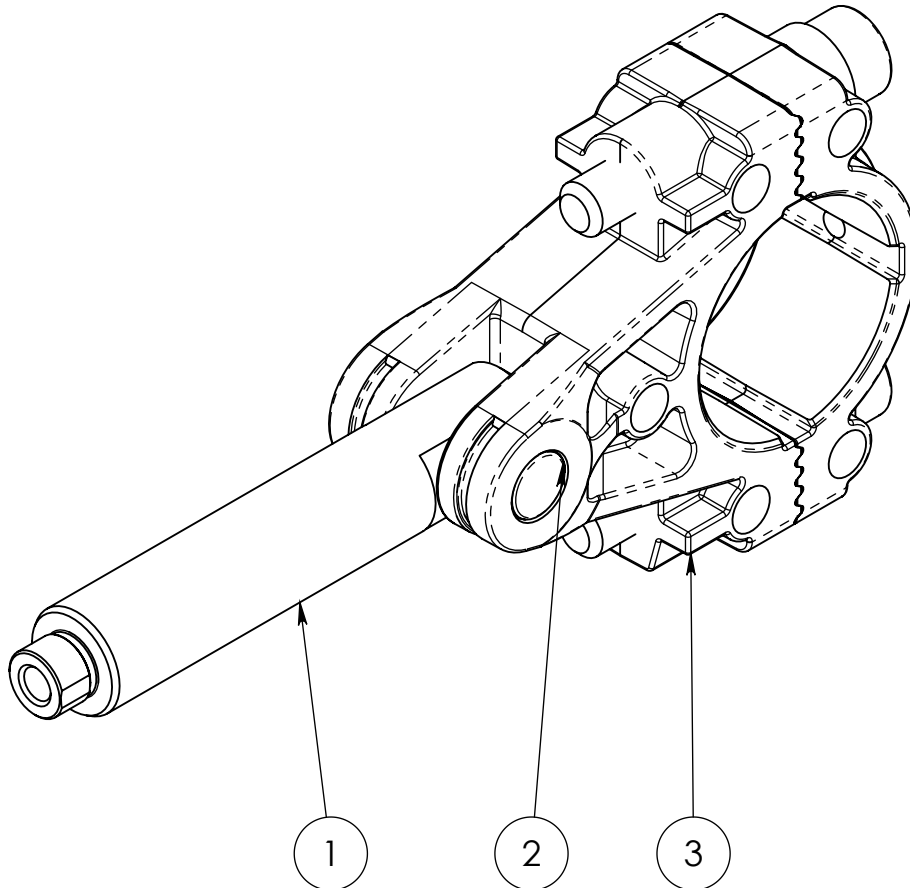

P2.150.006.B

Spare parts P9.041.004

Pos.	Q.ty	Code	ITALIANO	ENGLISH	DEUTSCH	ESPAÑOL	FRANCAIS
1	1	P1.010.008	Asta MMD	Pole MMD	Pfosten MMD	Asta MMD	Tige MMD
2	1	P1.013.004	Spina cilindrica ø10x30	Cylindrical pin ø10x30	Zylinder Stift ø10x30	Pasador cilindrico ø10x30	Goupille cylindrique ø10x30
3	1	P1.099.008	Biella MMD	Connecting rod MMD	Plenelstange MMD	Biela MMD	Bielle MMD

Cover MMD

Coperchio MMD

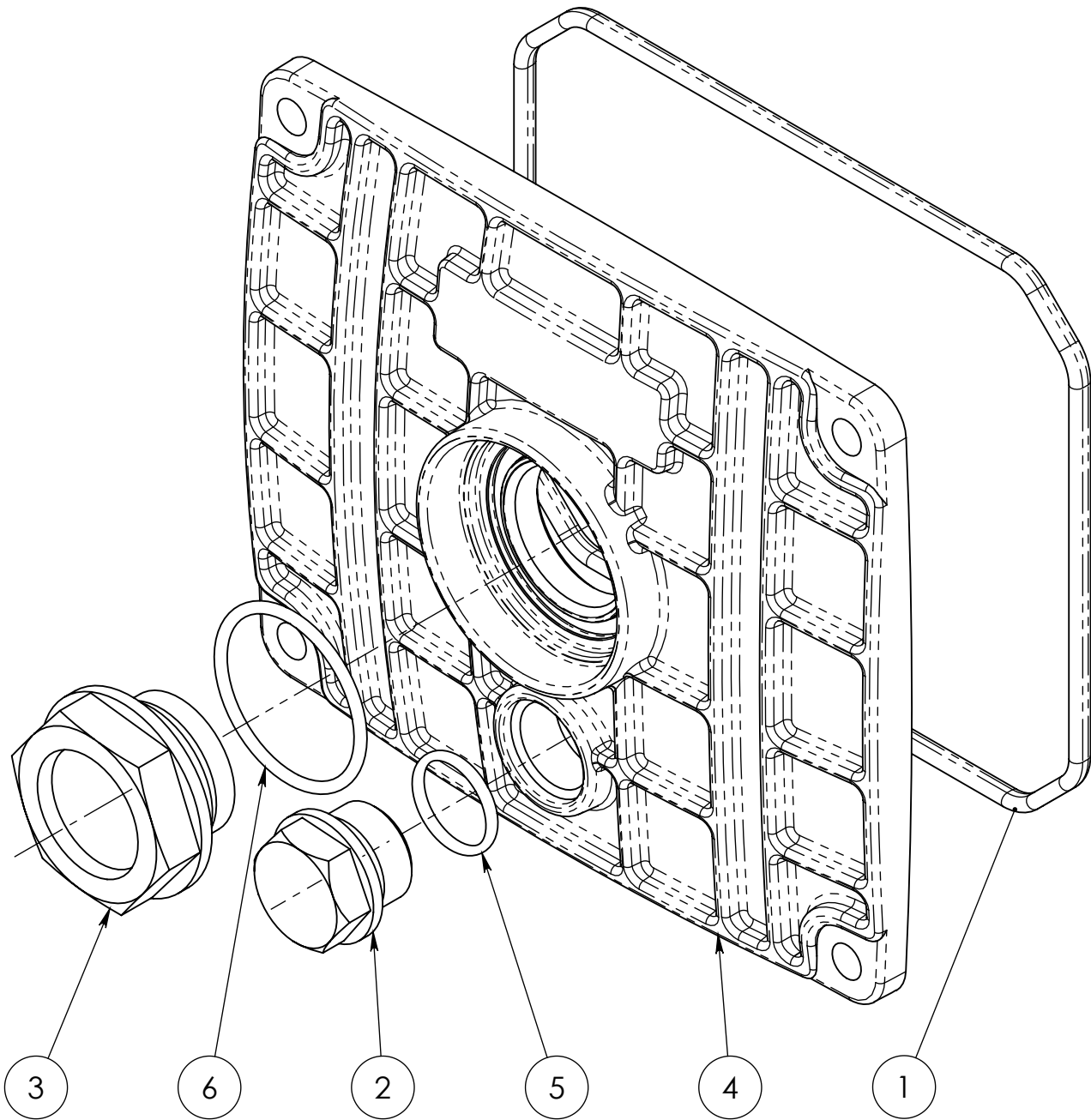

P2.012.001.G

Pos.	Q.Ty	Code	ITALIANO	ENGLISH	DEUTSCH	ESPANOL	FRANCAIS
1	1	P1.006.005	Guarnizione coperchio MMD	Lid gasket MMD	Deckeldichtung MMD	Junta de tapa MMD	Joint de couvercle MMD
2	1	P1.012.003	Tappo G 3/8" H18	Cap G 3/8" H18	Deckel G 3/8" H18	Tapón G 3/8" H18	Bouchon G 3/8" H18
3	1	P1.012.015	Tappo G3/4	Cap G3/4	Deckel G3/4	Tapón G3/4	Bouchon G3/4
4	1	P1.054.001	Coperchio "MM"	Cover "MM"	Deckel "MM"	Tapa "MM"	Couvercle "MM"
5	1	P4.005.007	Guarnizione OR 2056 14x1.78NBR 70Sh	Gasket OR 2056 14x1.78NBR 70Sh	Dichtung OR 2056 14x1.78NBR 70Sh	Guarnición OR 2056 14x1.78NBR 70Sh	Garniture OR 2056 14x1.78NBR 70Sh
6	1	P4.005.030	OR ORM0285-20 (NBR)	O-ring ORM0285-20 (NBR)	O-Ring ORM0285-20 (NBR)	OR ORM0285-20 (NBR)	Joint torique ORM0285-20 (NBR)