



# USE AND MAINTENANCE MANUAL

## INSTALLATION INSTRUCTIONS

TRANSLATION OF THE ORIGINAL INSTRUCTIONS



### PISTON PUMPS

## UDOR S.p.A.

Via Angelo Corradini, 2  
42048 Rubiera (RE) - ITALY  
Tel. 0522/628249 Fax 0522/628953  
[info@udor.it](mailto:info@udor.it) - [www.udor.it](http://www.udor.it)



Read this document carefully before carrying out any operation on the machine.  
This Manual is an integral part of the product and must always be available to its users.

<b>MACHINE TYPE</b>	PISTON PUMP	
<b>SERIES</b>	PN – PK – PS – PKWT – A – AWT – AK – B – BK – BCW – BWT – BS – C – CK – CX – CH – CS – CWT – NK – NK 500 – NH 500 – NKS – VX – VXX – VXS – VH – PENTA – PENTA 600 – GAMMA 62 – GAMMA 3P – GAMMA 6P – GAMMA-IL 3P – GAMMA-IL 6P – VX6	
<b>MODEL</b>	ALL	
<b>DOCUMENT TYPE</b>	USE AND MAINTENANCE MANUAL Code: 080595	
<b>REV.</b>	<b>DESCRIPTION</b>	<b>DATE</b>
4.0	New issue	03/2022
4.1	Changes to points 7 and 7.1	05/2024
4.2	Upgrade of pump series	03/2025

## TABLE OF CONTENTS

1	GENERAL INFORMATION .....	4
1.1	Structure of the Manual .....	4
1.1.1	Purpose and content .....	4
1.1.2	Recipients .....	4
1.1.3	Retention .....	5
1.1.4	Symbols used within the Manual .....	5
1.2	Manufacturer .....	5
1.3	Service Centres .....	5
1.4	CE Certification and Marking - Declaration of Incorporation .....	6
1.5	Warranty .....	7
2	GENERAL DESCRIPTION .....	8
2.1	Main components .....	8
2.1.1	<b>Overall dimensions</b> .....	9
2.2	Environmental conditions .....	9
2.3	Vibrations .....	9
2.4	Noise .....	9
2.5	High temperatures .....	9
2.6	Stability .....	9
2.7	Pressurised fluids .....	9
3	SAFETY .....	10
3.1	General warnings .....	10
3.2	Residual risks .....	11
3.3	Personal Protection Equipment .....	11
3.4	Products used .....	11
3.5	Plate .....	12
4	INTENDED USE .....	13
4.1	Intended Use .....	13
4.2	Contraindications for Use .....	13
5	INSTALLATION AND ASSEMBLY .....	14
5.1	Preparations by the Purchaser/User - Assembler .....	14
5.2	Handling .....	14
5.3	Assembly .....	15
5.4	Pump Fastening .....	16
6	PRELIMINARY CHECKS ON THE PUMP .....	17
6.1	Usable liquids .....	17
6.2	Pump Inlet and Outlet .....	17
6.3	Power supply conditions (Intake) .....	17
6.4	Outlet Conditions (Discharge) .....	18
6.5	Speed and direction of rotation .....	18
7	PRELIMINARY CHECKS ON THE SYSTEM .....	18
7.1	Pressure regulating valves .....	18
7.2	Nozzle .....	19
7.3	Pulsation damper (Accumulator) .....	19
7.4	Pressure gauge .....	19
8	START-UP AND SHUTDOWN .....	19
8.1	Start-up .....	19
8.2	Switch off and storage .....	20
8.3	Precautions against frost .....	20
9	MAINTENANCE .....	20
9.1	Routine maintenance .....	20
9.2	Lubrication .....	21
9.3	Oil and weight .....	22
9.4	Tightening torques .....	22
10	TROUBLE-SHOOTING .....	23
11	SPARE PARTS .....	24
12	PUMP DEMOLITION .....	24
13	ANNEXES .....	24

## 1 GENERAL INFORMATION

### 1.1 Structure of the Manual

This Manual has been prepared by the Manufacturer to provide the operating instructions and criteria to be followed for the installation, use and maintenance of the Pump. This Manual is an integral part of the official documentation of the Pump.

The Manufacturer reserves the right to make changes at any time without prior notice, except for changes in terms of safety.

The instructions are intended for experienced and appropriately trained operators who perform installation and routine maintenance.

The purchaser must ensure that the installation project is carried out in compliance with the instructions contained in this Manual, with the national and local laws and with the regulations in force.

The illustrations may differ from the actual configuration of the Pump but do not interfere with the presentation of the instructions. If in any doubt, ask the Manufacturer for the necessary clarifications.

**The Manufacturer is exempt from any liability for damage of any kind caused by incorrect use, negligence, superficial interpretations or by the complete failure to apply the safety concepts reported in this Manual.**

#### 1.1.1 Purpose and content

These user instructions contain all the indications concerning installation, use, maintenance, storage and all phases of the life cycle of the **PISTON PUMPS** that must be complied with by the assembler/end user to prevent possible risks.

Before carrying out any operation on the Pump, the operators and qualified technicians must carefully read the instructions contained in this publication.

If in any doubt about the correct interpretation of the instructions, contact UDOR S.p.A. for the necessary clarifications.

#### 1.1.2 Recipients

The instructions are intended for experienced and appropriately trained operators who perform installation and routine maintenance.

##### **Purchaser/User**

Person, entity or company who has purchased the Pump and intends to use it for its intended uses. This can be the assembler, if in possession of the necessary requirements.

##### **User/Operator**

Authorised person who possesses the requirements, skills and information necessary for use of the Pump, the machine or the system in which the Pump is installed and for routine maintenance.

##### **Assembler**

Authorised technician in possession of the requirements and specific skills to carry out the tasks related to the installation of the Pump and to perform routine maintenance operations in safe conditions, in an autonomous and risk-free manner. This may be the Purchaser/User.

The following definitions are recalled:

##### **Routine/general maintenance**

Set of interventions necessary to keep the machine in a good operating condition, to ensure a longer service life and to maintain the safety requirements. The intervals and methods of intervention are described by the Manufacturer in this Manual. These operations must be carried out by specialist personnel, that may be the operator, as described above.

### Extraordinary maintenance

Set of interventions to preserve the functionality and efficiency of the machine or to improve it. These operations must only be carried out by a specialist technician, authorised by the manufacturer.



### Training





Phase necessary to transfer to operators the knowledge necessary to perform the operations correctly while minimising risks.

#### 1.1.3 Retention

The Instruction Manual must be kept in the immediate vicinity of the machine, in a dedicated container, protected from liquids and from anything else that could compromise its legibility.

#### 1.1.4 Symbols used within the Manual

SYMBOL	MEANING	COMMENT
	<b>HAZARD</b>	Indicates a hazard with a serious risk for the user/assembler.
	<b>UPPER AND LOWER LIMB CRUSHING HAZARD</b>	Indicates the danger of crushing of the upper limbs when positioning or moving the Pump.
	<b>MOVING MECHANICAL PARTS HAZARD</b>	Indicates the danger due to the presence of mechanical parts during the processing (e.g. drive shaft, reducers, etc.).

SYMBOL	MEANING	COMMENT
	<b>WARNING</b>	Indicates a warning or note concerning key functions or useful information. Pay close attention to the text blocks indicated by these symbols.
	<b>SAFETY INFORMATION</b>	
	<b>CONSULTATION</b>	It is necessary to consult the Instruction Manual before carrying out a certain operation.
	<b>ADJUSTMENT/MAINTENANCE</b>	In cases of particular operations and/or anomalies, a particular mechanical adjustment may be required.

## 1.2 Manufacturer

	UDOR S.p.A. Via Angelo Corradini, 2 - 42048 Rubiera (RE) ITALY
---	---

## 1.3 Service Centres

For any requirement relating to the use or maintenance of the Pump, contact UDOR S.p.A. or the nearest service centre authorised by the Manufacturer.

For each request for technical assistance, indicate the data shown on the identification plate of the Pump and the type of anomaly found.

## 1.4 CE Certification and Marking - Declaration of Incorporation

The UDOR Piston Pumps referred to on the first page/header have been designed and built in accordance with the Machinery Directive 2006/42/EC and with the relevant European Community Directives and applicable at the time of placing on the market. According to this Directive, the Pumps in question are classified as "partly-completed machinery" and therefore, pursuant to article 2, letter g) of the afore-mentioned Directive, it is not possible to refer to certification but rather to Declaration of Incorporation. In fact, as can be seen from the content of the same, the Declaration of Conformity, with its CE marking, is the task of the Final Installer (which may be the purchaser).

In addition, these assembly instructions are drawn up in accordance with Annex VI of the afore-mentioned Directive. This Instruction Manual complies with Annex I section 1.7.4 of the afore-mentioned Directive as well as with the UNI 10893 standard and the ISO/IEC 37 guideline



A list of the Directives and standards applied can be found in the Declaration of Conformity in Annex I of this Manual.

### Facsimile



UDOR S.p.A. Via A. Corradini, 2 - 42048 Rubiera (RE) Italy  
Tel. +39 0522 628249 - Telefax +39 0522 628953  
E-mail: info@udor.it - http://www.udor.it



## DECLARATION OF INCORPORATION

*pursuant to Annex II, point B, to the Machinery Directive 2006/42/EC*

The Manufacturer

**UDOR S.p.A.**

Via A. Corradini, 2 - 42048 Rubiera (RE) - Italy

### DECLARES THAT THE DEVICE IDENTIFIED AND DESCRIBED AS FOLLOWS

Description	HIGH PRESSURE WATER PISTON PUMP
Series	See ATTACHMENT I, page.2
Model	See ATTACHMENT I, page.2

### IT COMPLIES WITH THE RELEVANT EUROPEAN UNION HARMONIZATION LEGISLATION

Directive 2006/42/EC "Machinery Directive" with special reference to the following ESHR:  
1.1.1 - 1.1.2 - 1.1.3 - 1.1.5 - 1.3.1 - 1.3.2 - 1.3.4 - 1.3.8.1 - 1.5.4 - 1.5.7 - 1.5.9 - 1.5.13 - 1.6.1 - 1.6.4 - 1.7.1.1 - 1.7.2 - 1.7.3 - 1.7.4 - 1.7.4.1

UNI EN ISO 12100:2010 Safety of machinery - General principles of design. Risk assesment and risk reduction  
UNI ISO/TR 14121-2:2013 Safety of machinery - Risk assessment - Part 2: Practical guidance and examples of methods  
UNI EN 809:2009 Pumps and pump units for liquids - Common safety requirements

### ADDITIONAL INFORMATION

The partly completed machinery MUST NOT BE PUT INTO SERVICE until the final machinery into which it is to be incorporated has been declared in conformity with the provisions of Directive 2006/42/EC.  
The relevant technical documentation was drafted in accordance with Annex VII, part B, to Directive 2006/42/EC.  
Upon motivated request by a National Authority, the Manufacturer agrees to provide information on the partly completed machinery by fax, email or hand within a reasonable period of time.

### PERSON AUTHORIZED TO COMPILE THE TECHNICAL DOCUMENTS

Name: **Paolo Lorenzini**

Address: **UDOR S.p.A., Via A. Corradini, 2 - 42048 Rubiera (RE) - ITALY**

### PERSON EMPOWERED TO DRAW THE DECLARATION

Rubiera (RE)  
12/11/2021

C.E.O. of UDOR S.p.A.

**Marco Zanasi**



## 1.5 Warranty

The warranty period for the Udor products is 12 (twelve) months from the date of shipment.

The warranty is limited to the replacement of parts or products that, at the sole discretion of Udor S.P.A., are considered defective from the time of shipment. The costs of labour and transportation remain the responsibility of the purchaser. The product must only be returned to UDOR S.P.A. with the authorisation of the same, ex warehouse UDOR S.P.A., must be complete with all its original components and must not have been tampered with. The replaced products or components become the property of UDOR S.P.A. The warranty of a product lapses if the terms of payment for the same by the purchaser are not respected.

The following types of damage are excluded from the warranty:

- Direct and indirect damage of any kind.
- Damage resulting from failure to comply with the safety regulations.
- Damage to products resulting from: incorrect use, falling, incorrect installation, exposure to frost, insufficient maintenance, neglect, inadequate storage and negligent use.
- Damage to components subject to normal wear and tear.
- Damage to the products in case of the use of non-original parts or parts not expressly approved by UDOR S.P.A.

UDOR S.P.A. reserves the right to make, at any time, changes deemed necessary to improve the product, without being obliged to apply these changes to products already sold or in the process of being shipped.

This warranty is the only valid one and supersedes any and all other warranties or conditions.

For any dispute, the Italian law will have jurisdiction in the court of Reggio Emilia.



**UDOR S.p.A. declines all responsibility for any errors generated in the drafting of this Manual.**



**For any modification to the product, or parts thereof, not agreed with the Manufacturer, the latter assumes no responsibility and will entail immediate forfeiture of the warranty**

## 2 GENERAL DESCRIPTION

The UDOR horizontal Piston Pumps are designed and built to pump or transfer **clean fresh or mixed water in low percentages with commonly used detergents (i.e. non-aggressive solutions) and up to a maximum temperature of 65°C\***.

**\*Only the series of pumps called WT can pump water at a maximum temperature of 85°C.**

They are generally operated by: electric motors, endothermic petrol or diesel engines, hydraulic motors, tractor power take-offs.

The couplings can be made by drive shaft, direct flange, reducer or multiplier, joints, pulleys and belts, referred to in Annex D of this Manual.

The Pumps are supplied as standard with the shaft power take-off on the right, looking at the Pump from the head side.

On request, all the Pump models can be supplied with left power take-off.



The Pumps referred to in this document are provided for the purpose of being installed on a more complex machine or system.

The Manufacturer of this machine or system must add all the information relating to the safety of the assembly made.

Before choosing and/or using each UDOR product, it is important that the purchaser carefully analyses all aspects relating to its specific application and thoroughly examines the information reported in the UDOR S.p.A. technical-commercial catalogues.

The products and the following document are subject to change by UDOR S.P.A. at any time without prior notice.



The Pumps referred to in this document are not designed to pump potentially dangerous liquids (explosive, toxic and flammable). Contact the Manufacturer if in any doubt.

Do not use the Pumps referred to in this document with different materials/fluids or with engine coupling systems other than those described.

If in any doubt contact the Manufacturer

### 2.1 Main components

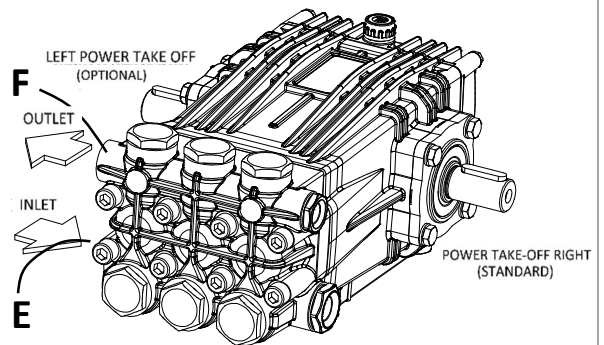
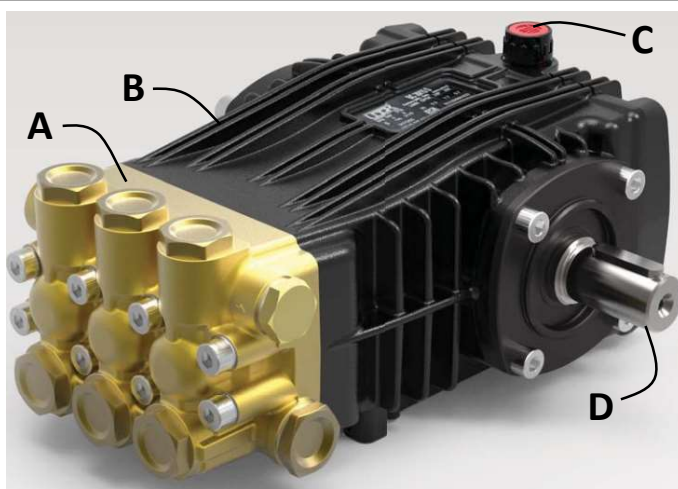

- A. HEAD
- B. PUMP BODY
- C. OIL LEVEL CAP
- D. ECCENTRIC SHAFT (PTO)
- E. INLET MOUTH (INTAKE)
- F. OUTLET MOUTH (DISCHARGE)

The pumping action is carried out by a series of pistons connected by connecting rods to the movement drive shaft. During movement the pistons slide axially inside the head where the intake and discharge ducts are equipped with valves that allow the passage of the liquid in only one direction.

### 2.1.1 Overall dimensions

The details of the technical characteristics for each range or series, together with the relevant models, are SET OUT IN ANNEX C to this document.

## 2.2 Environmental conditions

The UDOR Pumps covered by this Manual have been designed and built to work in light operating environments. The operating conditions are shown on the marking plate (see facsimile in para. 3.5). Here are some conditions.

Parameter	Permitted values
Ambient working temperatures	from 0°C to +45°C
Maximum temperature of the pumped fluids	+65°C
Maximum temperature of the pumped fluids PKWT; AWT; BWT; CWT; VXS WT; Series	+85°C

## 2.3 Vibrations

Under normal conditions of use, if the installation and assembly procedures contained in this document are carried out correctly, the UDOR Pumps do not generate vibrations such as to generate related risks. Furthermore, during operation, there is no contact with the operator, as the pumps are installed in a final machine/system that incorporates them. In different cases, the installer must proceed with their own risk assessment.

## 2.4 Noise

The pump is intended to be incorporated into a machine or system with different power supply systems that can also significantly vary the noise being emitted. It is the responsibility of the manufacturer of this machine or system to assess the noise level being emitted by the assembly and to also appropriately inform the user in relation to the use of suitable Personal Protection Equipment.

## 2.5 High temperatures

The mechanical parts are lubricated to avoid overheating conditions due to prolonged friction over time. The lubricating oil, indicated in the continuation of the Manual, has been chosen taking into account the characteristics of the Pumps that compose the complex. In addition, following normal maintenance procedures, this unforeseen event does not entail a risk in terms of probability.



Use suitable protection equipment, such as gloves and work clothes, when working on the Pump.

## 2.6 Stability

The UDOR Pumps are accompanied by the necessary instructions to ensure a stable and safe assembly in the machine/system in which they must be incorporated. The assembler/user must strictly follow and respect these instructions. The Udor Pumps have been designed and manufactured in such a way as not to present any type of risk regarding their stability, under normal conditions of use.



Further information is available in chapter 5 "Installation and Assembly".

## 2.7 Pressurised fluids

The Pumps covered by this Manual are made of materials suitable to withstand the envisaged operating pressures.

### 3 SAFETY



#### 3.1 General warnings

The UDOR Pumps have been designed to be safe in the use for which they are intended provided that they are put into operation (incorporated), used and maintained following the instructions contained in this use and maintenance Instruction Manual.

The operator and other personnel must, before installing and using the Pumps, carefully read and understand the instructions provided in the supplied Manual and the data of the installation project.

	<p><b>The Pump must not be tampered with otherwise any responsibility for correct operation or any damage caused by the product itself is disclaimed.</b></p>
	<p><b>Before using the Pump, make sure that any situation that poses a risk to safety has been appropriately eliminated.</b></p>



It is also essential that operators respect the warnings listed below:

	<p><b>Never start the Pump under pressure.</b></p>
	<p><b>Constantly check the state of wear of the pipes and of the relative connections, in particular those under pressure. Pipes that have abrasions and that do not guarantee a perfect seal must be replaced.</b></p>
	<p><b>The Pump must never run dry during use.</b></p>
	<p><b>Do not attempt to disassemble or modify parts of the Pump, except in the cases and in the manner described in this Manual.</b></p>
	<p><b>Wear the Personal Protection Equipment prescribed by the Manual according to the operations to be performed.</b></p>
	<p><b>Do not wear loose or dangling rings, wristwatches, jewellery, clothing such as ties, scarves, torn clothing, unbuttoned jackets or blouses with open zips that could become caught in moving parts.</b></p>
	<p><b>In case of anomalies or damage that could compromise the functionality and safety of the Pump it is necessary to remove it <i>immediately</i> from service.</b></p>
	<p><b>Make sure that all guards or other protections are in place and that all safety devices are present and efficient (Pump casing and safety devices of the machine/system in which it is incorporated).</b></p>
	<p><b>Do not allow unauthorised personnel to intervene on the Pump.</b></p>

	<p><b>Refer to the Use and Maintenance Manual of the final machine in which the Pump is incorporated for additional required safety conditions.</b></p>
---	---

### 3.2 Residual risks

The Pump is designed and built with the intention of eliminating all risks related to its use. The residual risks are specified below:

a) Crushing:	
A risk of crushing of the upper limbs, hands or feet may arise during movement and positioning of the Pump. Pay particular attention during these phases. Please note that it is necessary to use the personal protection equipment delivered (gloves and shoes) and to follow all the procedures drawn up for correct execution of this phase.	
b) Thermal hazard:	
During operation the Pump, in relation to the temperature of the liquid being pumped, can reach high temperatures. For this reason, the person responsible for incorporating the Pump into a final machine/system (Purchaser/User or Assembler) must take this fact into account during installation and must provide the appropriate protections and warning signs for personnel.	

### 3.3 Personal Protection Equipment

	<b>Failure to use personal protection equipment, indicated in this paragraph, results in exposure to hazards for operators. The employer is required to provide the workers operating on the machine referred to in this Manual with personal protection equipment.</b>
---	---

The operators assigned to use of the Pump, due to the operations being carried out, are required to wear at least the following personal protection equipment:

- protective gloves against the risk of cuts, abrasions
- safety shoes
- protective goggles (if necessary)



	<b>Refer to the Use and Maintenance Manual of the final machine in which the Pump is incorporated for additional required safety conditions.</b>
---	--

### 3.4 Products used

All products used for normal operation of the Pump, such as oils, lubricants and cleaning products, must be used in accordance with the provisions indicated in the safety data sheets issued by the manufacturer.

**The oil used for the UDOR Pumps referred to in this document is: SAE 15W/40.**

Any disposal must take place in accordance with the specific provisions of the laws in force.

	Further information is available in chapter 9 "Maintenance".
---	--

	<b>Do not use products other than those indicated. If in any doubt, contact the Manufacturer.</b>
---	---

### 3.5 Plate

An exact description of the Pump, model, serial number and technical data will facilitate quick and effective responses from the assistance service (where envisaged).

The identification data are shown on the Pump plate, as indicated below.



**It is absolutely forbidden to remove (or reposition) from the Pump any type of plate and/or labels bearing information and/or used for warning functions.**

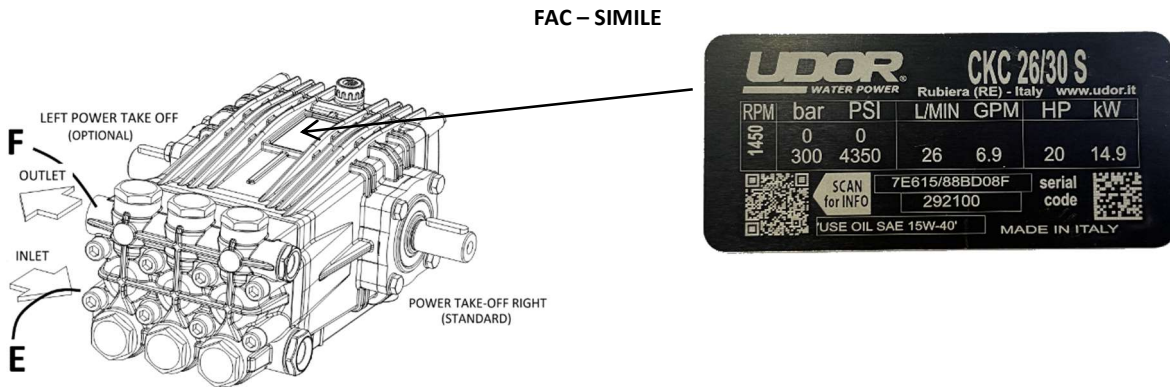

#### Additional signs affixed to the Pump

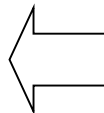

The plate is positioned near the blind cap, in the upper part of the pump body  
 There is also a version translated into English and Chinese

## 4 INTENDED USE

### 4.1 Intended Use

The UDOR Piston Pumps are intended to be used within machines or systems for the transfer of pressurised water such as: Vehicle washing, Civil and industrial washing, Road and Bin washers, Water treatment, Misting, Purging, Fire prevention. In addition, they must be used in a manner that corresponds to their technical characteristics (para. 2.1.1), without undergoing unagreed modifications or being used for improper uses.



**They must ONLY be used and installed by trained and qualified personnel who are aware of the information in this Manual.**



**It is forbidden to operate the Pump until the machine in which it is incorporated has been declared compliant with the relevant legislative provisions (Dir. 2006/42/EC).**

### 4.2 Contraindications for Use

It is **FORBIDDEN** to use the Pump:



- For purposes other than those indicated in section 1.1.2
- For uses other than those set out in section 2 and section 4.1
- Under environmental conditions other than those indicated in section 2.2
- In applications other than those indicated in para. 4.1
- For flammable, toxic, corrosive liquids (paints, solvents, fuels...) or for liquids with unsuitable density and at temperatures higher than those provided for by the technical characteristics reported in this document or on the plate
- For fluids other than those listed in Chapter 2
- For drinking use water mains
- For food use
- For pharmaceutical products



**For any other uses of the Pump other than those mentioned above, the Manufacturer reserves the right to review the warranty conditions of the Pump.**



## 5 INSTALLATION AND ASSEMBLY

Read this chapter carefully before installing the machine.

	<b>Incorrect installation in your pumping system can cause injury to persons and damage to property. It is therefore essential to respect all the points listed below.</b>
	<b>During the installation and assembly phase it is necessary to observe the utmost cleanliness.</b>

### 5.1 Preparations by the Purchaser/User - Assembler

The customer is responsible for the following preparations:

	<b>The assembler/end user must provide for the installation of a maximum pressure valve at the pump discharge mouth.</b>
	<b>For all connection operations, strictly follow the specifications indicated in the Use and Maintenance Manual of the final machine in which the Pump is incorporated.</b>

### 5.2 Handling

The packaging in which the UDOR Pumps are contained has been specially designed to prevent damage due to impacts or vibrations during transportation or handling.

	<b>When unpacking, check the integrity and exact quantity of the components and if damaged or missing, contact the dealer or directly the Manufacturer to agree on the procedures to be adopted. The packaging material must be properly disposed of in compliance with the laws in force.</b>
---	--

Depending on the quantity of goods to be shipped and the place of destination, the packages can be fixed on a pallet to facilitate lifting and handling.

Smaller, low-weight pumps can be handled in accordance with the current legislation.

For those of greater weight, the appropriate eyebolt must be used by hooking it to a rope or chain with the appropriate hook and using a suitable lifting device.

In the absence of an eyebolt, if it is necessary to use a lifting tool, use a strap/straps being careful not to damage the product. The weight of the pumps is shown on the relevant data sheet (Annex C).

	<p>Before starting operations, organise the work area in such a way as to allow the lifting and movement of materials safely.</p>
	<p>Unloading, loading, handling and lifting operations must be carried out by qualified, authorised persons with specific professional training.</p>
	<p>During lifting and handling operations, persons not involved in the operations must remain at a safe distance.</p>
	<p>All lifting equipment used, including accessories (hooks, ropes, chains, straps, etc.), as well as any used for transportation, must be of adequate capacity according to the weight to be lifted.</p>
	<p>Failure to comply with the following indications may result in situations of serious danger</p>

	<p>If the Pump is used in a particularly dirty environment or exposed to atmospheric agents, it is advisable to protect it respecting the ventilation conditions.</p>
---	---

### 5.3 Assembly

The Pumps can be installed in various ways: with pulley and belt drive, direct drive or with flange and joint coupling. In case of belt drive, carefully check the alignment of the pulleys and the tension of the belts. In case of coupling with flange it is necessary to use a suitable elastic coupling joint. (Annex D). Exposed moving parts can be dangerous, so they must be adequately protected. In the case of rotating shafts equipped with tabs or other exposed protrusions capable of causing cuts or entanglement, they must be provided with guards. The guards that perform the function of protections must only be removable with the use of a tool. Use suitably sized flexible hoses both at the inlet and outlet of the Pump according to the technical characteristics shown on the Plate.

	<p>For the drive with pulleys, ensure alignment of the same, adjust the tension of the belts and provide adequate safety protection. Excessive belt tension can cause the oil to overheat, reduce bearing life and create an explosion hazard.</p>
---	--

	<p>To prevent accidents it is essential to install a safety/exhaust valve to prevent the pressure from accidentally exceeding the operating value.</p>
---	--

	<p>The Manufacturer is not liable for damage caused by types of connections with different characteristics or not indicated in this Manual or for direct damage to property and/or persons resulting from moving parts left uncovered or caused by unsuitable protections. If in any doubt, it is advisable to contact the Manufacturer's Technical Department.</p>
---	---

### 5.4 Pump Fastening

Assemble the Pump on a rigid surface while keeping the power take-off and support feet horizontal in order to allow correct drainage in the event of water or oil spills.

Attach the Pump to the support with screws appropriate to the diameter and depth of the holes provided in the Pump body (see fig. below).

The illustration shows the maximum permissible inclination of the Pump to ensure correct lubrication of the crank drive.

SERIES	A	B	C	D
PN-PK-PS-PKWT	47.5	80	-	M8x10
A-AK-AWT	90	80	-	M8x10
B-BK-BS-BWT	125	95	-	M8x14
C-CK-CX-CH-CS-CWT	145	105	-	M10x16
NK-NK 500-NH 500-NKS	155	185	-	M12x17
PENTA-PENTA 600	195	210	160	M14x32
VX-VH-VXX-VXS-VX6	195	210	110	M14x32
GAMMA 62	113	215	-	Ø11
GAMMA 85/105/125/155 GAMMA-IL 83/103	176	264	88	Ø13
GAMMA 162/202/242 GAMMA-IL 160/200 VX6	200	268	100	Ø13

## 6 PRELIMINARY CHECKS ON THE PUMP

### 6.1 Usable liquids

The Pump has been designed and built for the transfer of clean water or non-aggressive aqueous solutions.

The aspirated liquid must be free from sand or other solid suspended particles.

The aspirated liquid must have viscosity and density characteristics similar to water.

The maximum temperature of the liquid to be pumped varies depending on the system conditions (see section 6.3 - SUPPLY CONDITIONS).



**Comply with all the requirements and limits described in chapter 4 – INTENDED USE.**  
**Any other use is not permitted unless there is a written exception from the UDOR S.P.A. Technical Service.**

### 6.2 Pump Inlet and Outlet

The inlet mouth of the liquid to be pumped is located at the bottom of the pump head and can also be called Intake or Supply. The outlet mouth of the pumped liquid is located at the top of the head and can also be called Discharge (see fig. paragraph 2.1).

The Inlet and Outlet mouths can be used independently, either from the right or left side of the Pump head, possibly disassembling or reversing the closing caps.



**The Pump Inlet and Outlet CANNOT be reversed between each other.**

### 6.3 Power supply conditions (Intake)

Pump installed above the supply tank.	Pump installed under the supply tank with falling liquid.	Pump installed with pressurised supply.
Maximum permissible difference in level between the Pump and the tank liquid: 0.5 m / 1.6 ft.	Maximum permissible pump rotation speed: 1750 RPM.	Maximum permissible pump inlet pressure: 6 bar (90 PSI).
Maximum permissible operating pressure: 200 bar (3000 PSI).	Pump inlet liquid temperature, maximum permitted: 50°C (122°F) for operating pressure up to 200 bar.	Any Booster Pump must be started before the Piston Pump.
Maximum permissible negative intake pressure: -0.2 bar (-6 inch.Hg).		The power source must be able to provide at least 50% more of the pump flow.
Maximum permissible pump rotation speed: 1450 RPM.	Pump inlet liquid temperature, maximum permitted: 35°C (104°F) for operating pressure above 200 bar.	Maximum permissible pump inlet liquid temperature: 50°C (122°F).
Maximum permissible pump inlet liquid temperature: 40°C (104°F).		

**The supply line must comply with the following requirements:**

- ✓ Have, at each point, a minimum inner diameter equal to the inner diameter of the inlet of the Pump.
- ✓ Be perfectly airtight in order to avoid damaging air infiltrations.
- ✓ Be absolutely free from 90° elbows near the Pump inlet,
- ✓ Be absolutely free from constrictions or narrowing of the ducts, throughout its length.
- ✓ Absolutely avoid turbulence near the inlet of the Pump and in the supply tank.
- ✓ Any filter must have a minimum capacity of at least 2 times the flow rate of the Pump and must not cause constrictions or pressure drops. The recommended filtration degree is 50 ÷ 80 mesh and must be kept efficient by cleaning the filter if necessary.



**Any other use is not permitted unless there is a written exception from the UDOR S.P.A. Technical Service.**

### 6.4 Outlet Conditions (Discharge)

Check that the discharge line and all accessories are correctly connected, securely fixed, hermetically sealed and that the pipes are suitably sized. All pressure pipes must be permanently marked with the maximum value from the permissible pressure that must never be lower than the maximum operating pressure of the Pump shown on the Plate.

### 6.5 Speed and direction of rotation

The minimum number of revolutions permitted is: Maximum RPM x 0.6.

The direction of rotation of the UDOR Pumps shaft can be either clockwise or anti-clockwise.



**The speed of rotation of the Pump shaft must never exceed the value of the rpm (RPM) indicated on the Pump Plate itself.**

## 7 PRELIMINARY CHECKS ON THE SYSTEM

By way of example, the diagram of a circuit is shown below:

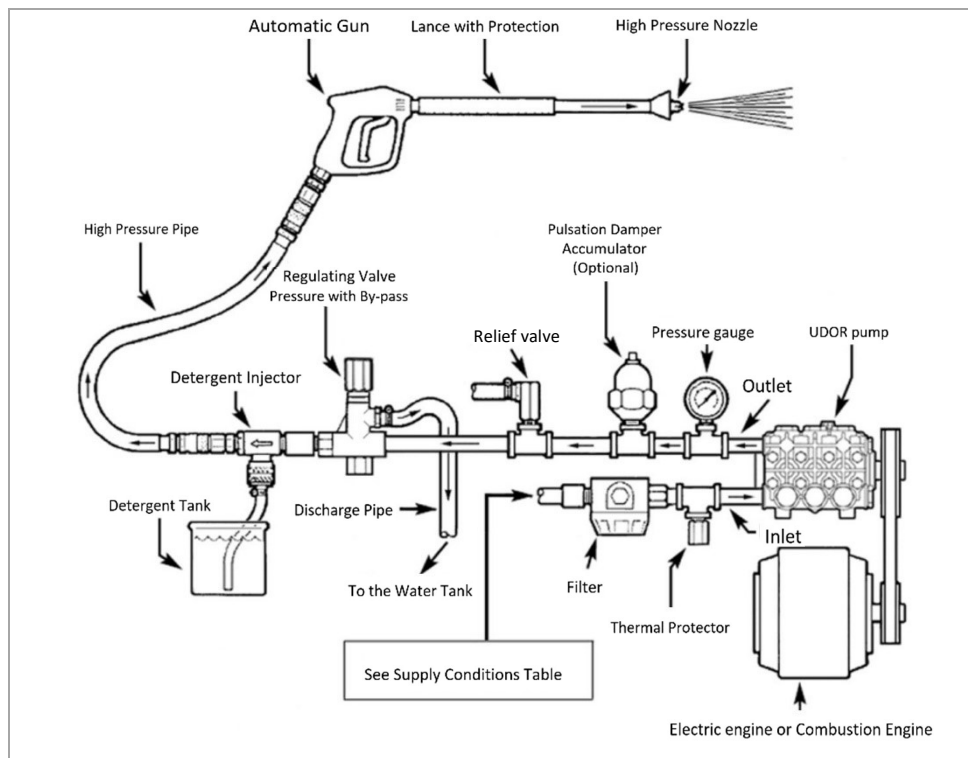

**All the components of the machine or circuit in which the Pump is integrated must have technical characteristics compatible with the data shown on the Pump Plate.**

### 7.1 Pressure regulating valves

A pressure regulating valve (not supplied with the Pump) must be installed to avoid overpressure beyond the maximum limit indicated on the Pump Plate.



**Use, even for a short period of time with a pressure higher than this limit would cause damage to the Pump itself.**

The choice of the control valve must be made compatibly with the maximum pressure, flow and temperature data shown on the Plate and in the conditions described in "6.3 - SUPPLY CONDITIONS".



**Incorrect installation of the pressure regulating valve can cause serious damage to persons and property as well as seriously damaging the Pump itself.**  
**The circuit must be equipped with an relief valve to prevent the maximum pressure from being exceeded in the event of a failure of the pressure regulating valve.**

## 7.2 Nozzle

A deteriorated nozzle causes a pressure drop; in this case, do not intervene on the pressure regulating valve to try to increase the pressure of the system as, at the end of the discharge, it would cause a pressure surge that could damage the Pump. In the presence of a pressure drop, it is advisable to replace the nozzle and re-adjust the pressure in the system. The flow rate of the Pump must be at least 10% higher than the flow rate required by the uses; the excess flow rate must be discharged. The choice of the nozzle (not supplied with the Pump) must be made by consulting the tables in this Manual (Annex B).

## 7.3 Pulsation damper (Accumulator)

For those applications in which the pulsations produced by the pump on the discharge line were harmful or undesirable, it is advisable to install a suitably sized pulsation damper (not supplied with the pump).

## 7.4 Pressure gauge



**Install a pressure gauge (not supplied with the Pump) as close as possible to the outlet of the Pump as the maximum pressure indicated on the Pump Plate refers to the pressure detected on the Pump head and not to the nozzle or other accessories.**

# 8 START-UP AND SHUTDOWN

## 8.1 Start-up

Before commissioning, carry out the following preliminary checks:

1. Replace the RED cap fitted on the Pump casing with the VENT cap inserted in the "accessory kit" supplied:



2. - Check the oil level from the appropriate cover or indicator cap; top up if necessary.
3. - Check the accumulator pressure value, if present; inflate or deflate if necessary.
4. - The pressure regulating valve must be adjusted to pressure "0" to facilitate suction.

Start the Pump for approximately 10 seconds until the liquid completely escapes from the discharge pipe.

Once the intake cycle has been completed, it is possible to bring the Pump to the desired pressure value, by acting on the pressure regulating valve, without ever exceeding the maximum pressure value shown on the Pump Plate itself.





**Always observe all the safety provisions indicated in chapter 3.**

**In any case, if the Pump does not appear suitable for correct and safe operation, IT must be taken OUT OF SERVICE until the damaged parts are repaired or replaced.**

## 8.2 Switch off and storage

After use or in case of storage it is advisable to wash the inside of the Pump. The operation can be performed by running the Pump for a few minutes with clean water, then disconnect the supply pipe and let the Pump run for approximately 15 seconds so that all the water contained in the Head comes out.

A few minutes dedicated to the internal washing of the Pump entail a considerable benefit in terms of the lifetime of the Pump itself.

	<p><b>Do not wash the Pump externally: water could enter inside the Pump casing for example through the oil vent.</b></p>
	<p><b>Do not disperse the liquid used for washing in the environment but comply with the current legislation.</b></p>

	<p><b>After switching off, the Pump may still have hot surfaces. Wear the appropriate prescribed PPE and, if necessary, wait for a short time before intervening (e.g. 20 min).</b></p>
---	---

## 8.3 Precautions against frost

In the case of winter shutdowns or in areas and at periods of the year at risk of frost, at the end of the work, turn the Pump for the time necessary to put into circulation an emulsion consisting of 50% clean water and 50% antifreeze liquid in order to prevent freezing and damage to the Pump.

	<p><b>The Pump must not be used to pump antifreeze liquid not mixed with water.          In the presence of ice or very low ambient temperatures, the Pump must never be started!          Doing so could result in serious damage to the Pump itself.          In order to start the system, it is essential that the entire circuit is completely thawed.</b></p>
---	---

# 9 MAINTENANCE

## 9.1 Routine maintenance

	<p><b>Always observe all the safety provisions indicated in chapter 3.</b></p> <hr/> <p><b>All maintenance work must be carried out by authorised and qualified personnel and recorded in a dedicated register.</b></p>
---	---

When carrying out maintenance or repair work, it is advisable to apply the following recommendations:

- Before carrying out any maintenance work, it is necessary to depressurise the water system and isolate the Pump from all energy sources;
- Wait until the machine has adequately cooled down and returned to idle conditions;
- Before starting work, display a "**MACHINE UNDER MAINTENANCE**" sign in a clearly visible position;
- Do not use flammable products and materials;
- To handle lubricants wear gloves that are resistant to mineral oils, overalls (the trousers must always be outside the safety shoes) and safety glasses;
- Be careful not to disperse lubricating oils and greases into the environment.

If the Pump is used for light work, the following routine maintenance operations are recommended:

- ✓ After the first 50 hours:  
Oil change (see paragraph 9.2 - Lubrication)
- ✓ Every 500 hours:  
Oil change (see paragraph 9.2 - Lubrication)
- ✓ Every 1000 hours:  
Replacement of Valves - Replacement of piston seal rings

Check that the retaining screws of the Pump are not loose. If necessary, tighten them with the tightening torque indicated in paragraph 9.4

For heavy duty use, shorten the intervention intervals.



In case of inspection or replacement of the Pump valves, pay particular attention to the type of Loctite® to be applied to the closing caps of the valves themselves (see the following paragraphs).



In case of any anomaly, the cause must always be found and the anomaly resolved before the machine can be put back into operation.  
For any maintenance (not indicated in this Manual or in its annexes) contact the Manufacturer in advance.

## 9.2 Lubrication

The Pump is supplied with the correct quantity of lubrication oil (see para. 9.3).

Periodically check the oil level inside the Pump using the appropriate level indicator.

Use SAE 15W-40 OIL or oil of corresponding characteristics. Here are some types of recommended oils:

BRAND	TYPE
AGIP	F.1 Supermotoroil 15W-40
BP	Vanellus C 15W-40
CASTROL	GTX 15W-40
ESSO	Uniflo 15W-40
MOBIL	Super M 15W-40
SHELL	Rimula R4 15W-40 / Helix Super 15W40
TOTAL	Rubia 15W-40 / Quartz 5000 15W-40



The oil change operation must be carried out by draining the oil from the relevant lower drain cap and strictly with the pump stopped.

Each time the oil drain cap is disassembled, it is advisable to replace the sealing gasket.



**DO NOT START THE PUMP IN THE ABSENCE OF OIL IN THE CASING!**



In the event of disposal:

1. Separate the components according to the type (e.g. plastic, hazardous liquids, metal, etc.).
2. Public or private collection systems provided for by the local legislation must be used for disposal.
3. This equipment may contain hazardous substances: improper use or incorrect disposal could have adverse effects on human health and on the environment.

### 9.3 Oil and weight

SERIES	RECOMMENDED QUANTITY OF OIL				PUMP WEIGHT	
	Kg.	Lbs.	Lt.	Gal.	Kg.	Lbs.
A	0,35	0,77	0,39	0,1	6,3 ÷ 7,3	13.9 ÷ 16.1
AK	0,35	0,77	0,39	0,1	7,3 ÷ 8,3	16.1 ÷ 18.3
AWT	0,35	0,77	0,39	0,1	7,0	15.4
PN	0,26	0,57	0,29	0,08	5,3 ÷ 6,0	11.7 ÷ 13.2
PS (Inox - Stainless Steel)	0,32	0,70	0,36	0,09	6,6	14.6
PK	0,32	0,70	0,36	0,09	6,3 ÷ 7,3	13.9 ÷ 16.1
PKWT (HWT)	0,32	0,70	0,36	0,09	6,2	13.7
B	0,42	0,93	0,47	0,12	9,1 ÷ 10,3	20.1 ÷ 22.7
BK	0,42	0,93	0,47	0,12	10,5 ÷ 11,6	23.1 ÷ 25.6
BS (Inox - Stainless Steel)	0,42	0,93	0,47	0,12	10,3	22.7
BWT (HWT)	0,42	0,93	0,47	0,12	9,3	20.5
BCW	0,42	0,93	0,47	0,12	9,3	20.5
C	0,93	2.05	1,04	0,27	14,8 ÷ 16,2	32.6 ÷ 35.7
CS (Inox - Stainless Steel)	0,93	2.05	1,04	0,27	19,7	43.4
CWT (HWT)	0,93	2.05	1,04	0,27	14,8 ÷ 17,5	32.6 ÷ 38.5
CK	0,93	2.05	1,04	0,27	17,5	38.5
CX	0,93	2.05	1,04	0,27	24,1 ÷ 25,1	53.1 ÷ 55.3
CH	0,93	2.05	1,04	0,27	21,1	46.5
NK - NH	1,5	3.3	1,7	0,45	30,5 ÷ 34.4	67.2 ÷ 75.8
NKS (Inox - Stainless Steel)	1,5	3.3	1,7	0,45	36,2	79.8
GAMMA 62	1,5	3.3	1,7	0,45	22,2	49.0
GAMMA 85 / 105 / 125 /155	3,4	7.5	3,8	1.00	37,6 ÷ 38,0	82.9 ÷ 83.7
GAMMA 162 / 202 / 242	1,7	3.7	1,9	0.50	51,8 ÷ 52,0	114.2 ÷ 114.6
GAMMA-IL 83 / 103	3,4	7.5	3,8	1.00	53,3	117.5
GAMMA-IL 160 / 200	1,7	3.7	1,9	0.50	69,0	152.1
PENTA	3,1	6.8	3,5	0.92	43,8 ÷ 44,5	96.6 ÷ 98.1
VX - VXX	3,4	7.5	3,8	1.00	57,9 ÷ 58,5	127.6 ÷ 129.0
VX6	1,7	3.7	1,9	0.50	90,0	198.0
VXS (Inox - Stainless Steel)	3,4	7.5	3,8	1.00	68,0	149.0
VH	3,4	7.5	3,8	1.00	66,0	145.5

### 9.4 Tightening torques

See Annex E at the end of this Manual

## 10 TROUBLE-SHOOTING



All troubleshooting operations must be carried out by authorised and qualified personnel.  
If in any doubt, contact the Manufacturer.

The purpose of this paragraph is to provide the User with solutions to the problems or malfunctions that may occur most frequently.

PROBLEMS	PROBABLE CAUSES	SOLUTIONS
The Pump does not reach the required pressure.	Inadequate, worn or dirty nozzle.	Clean or replace the nozzle.
	The belts are slipping.	Tighten or replace the belts.
	Air intakes from the supply.	Check or replace hoses or connections.
	Supply pipe obstructed or undersized.	Check and clean the pipe or size it correctly.
	Gaskets damaged due to: abrasive substances in the liquid being used; cavitation due to poor power supply.	Install a suitable filter. Replace the gaskets. Check the supply vacuum: max. -0.2 bar (-6 inch.Hg).
	Pressure gauge out of use or not calibrated.	Check the pressure with a new pressure gauge; replace if necessary.
	Pressure or safety control valve incorrectly calibrated, worn or dirty.	Calibrate, repair or replace the valve(s).
Noisy pump.	Pump valves worn or dirty.	Clean or replace the valves.
	Liquid leaks from the discharge circuit.	Check or replace hoses or connections.
	Air intakes from the supply.	Check or replace hoses or connections.
	Supply pipe obstructed or undersized.	Check and clean the pipe or size it correctly.
	Pump valves worn or dirty.	Clean or replace the valves.
	Worn gaskets or ORs.	Replace the gaskets and/or ORs.
	Inadequate or dirty filter.	Correctly size, clean or replace the filter.
Water leaks from the head.	Pulley with too much play on the shaft or shaft tab damaged.	Check the correct fixing of the pulley. Check or replace the tab.
	Bearings worn or damaged.	Replace the bearings.
	Low pressure or worn OR gaskets.	Replace the gaskets and/or ORs.
Presence of water inside the oil.	Broken pistons.	Replace the pistons.
	High percentage of humidity in the air.	Change the oil every 250 hours instead of 500.
The oil turns white.	Casing sealing rings worn.	Replace the sealing rings.
Oil leaks between the casing and the head.	Completely worn gaskets.	Replace the gaskets.
	Casing sealing rings worn.	Check the piston guide rods. Replace the sealing rings.
Oil leaks in the shaft area.	Worn shaft sealing ring.	Replace the sealing ring.
	Damaged flange OR.	Replace the OR.
	Damaged bearings.	Replace the bearings.
Oil leaks in the back of the Pump.	Incorrect assembly or damage to the oil level cap or the oil drain cap or the gasket between the cover and the casing.	Replace defective caps or gaskets.
Frequent or early wear of the gasket pack.	Damaged pistons.	Replace the pistons.
	Excessive pressure at pump inlet.	Reduce the supply pressure.
	Abrasive substances in the liquid being used.	Install the appropriate inlet filter.
	Corrosive additives present in the liquid being used.	Use clean water or contact UDOR S.P.A. Technical Service for information.
	Excessive temperature of the liquid being used.	Do not use hot water (see page 9)
Excessive vibrations on the discharge line.	The pump has run dry.	The Pump must never run dry.
	Air intakes from the supply.	Check or replace hoses or connections.
	Discharge pressure accumulator.	Check the pressure in the accumulator.
	Worn or dirty valves.	Clean or replace the valves.

## 11 SPARE PARTS

In ordinary and/or extraordinary maintenance use only original spare parts.  
For information contact the Manufacturer or its assistance service.

## 12 PUMP DEMOLITION

Demolition of the Pump must be entrusted to expert personnel in compliance with the laws in force regarding safety at work.

The disassembled components must be separated according to the nature of the materials they are made of. Do not disperse polluting materials such as lubricants into the environment.

Dispose of in compliance with the laws in force on the "Collection and separate disposal of waste".



The Pump contains precious recyclable materials which should therefore be recycled to ensure their use.

Therefore, dispose of the used Pump through suitable collection centres.

## 13 ANNEXES

- A. Declaration of incorporation
- B. Nozzles table
- C. Technical data sheets
- D. Engine coupling systems
- E. Tightening torques

# ANNEX A

## DECLARATION OF INCORPORATION

## DECLARATION OF INCORPORATION

pursuant to Annex II, point B, to the Machinery Directive 2006/42/EC

**The Manufacturer****UDOR S.p.A.**

Via A. Corradini, 2 - 42048 Rubiera (RE) - Italy

**DECLARES THAT THE DEVICE IDENTIFIED AND DESCRIBED AS FOLLOWS**

<b>Description</b>	HIGH PRESSURE WATER PISTON PUMP
<b>Series</b>	See ATTACHMENT I, page.2
<b>Model</b>	See ATTACHMENT I, page.2

**IT COMPLIES WITH THE RELEVANT EUROPEAN UNION HARMONIZATION LEGISLATION**

Directive 2006/42/EC "Machinery Directive" with special reference to the following ESHR:

1.1.1 - 1.1.2 - 1.1.3 - 1.1.5 - 1.3.1 - 1.3.2 - 1.3.4 - 1.3.8.1 - 1.5.4 - 1.5.7 - 1.5.9 - 1.5.13 - 1.6.1 - 1.6.4 - 1.7.1.1 - 1.7.2 - 1.7.3 - 1.7.4 - 1.7.4.1

UNI EN ISO 12100:2010 Safety of machinery - General principles of design. Risk assesment and risk reduction

UNI ISO/TR 14121-2:2013 Safety of machinery – Risk assessment - Part 2: Practical guidance and examples of methods

UNI EN 809:2009 Pumps and pump units for liquids - Common safety requirements

**ADDITIONAL INFORMATION**The partly completed machinery **MUST NOT BE PUT INTO SERVICE** until the final machinery into which it is to be incorporated has been declared in conformity with the provisions of Directive 2006/42/EC.

The relevant technical documentation was drafted in accordance with Annex VII, part B, to Directive 2006/42/EC. Upon motivated request by a National Authority, the Manufacturer agrees to provide information on the partly completed machinery by fax, email or hand within a reasonable period of time.

**PERSON AUTHORIZED TO COMPILE THE TECHNICAL DOCUMENTS**Name: **Paolo Lorenzini**Address: **UDOR S.p.A., Via A. Corradini, 2 - 42048 Rubiera (RE) - ITALY****PERSON EMPOWERED TO DRAW THE DECLARATION****Rubiera (RE)****12/11/2021**

C.E.O. of UDOR S.p.A.

**Marco Zanasi**

FIRMA

**ATTACHMENT I**

LIST OF EQUIPMENT THAT THE DECLARATION OF INCORPORATION REFERS TO:

Series	Model
PN/PS	PNC-S; PND-S; PNE-S; PND-Z; PNC-I; PNL-T; PND-T MI; PSC-S; PSD-Z
PK/PKWT	PKC-S; PKD-S; PKD-U; PKL-T; PKL-W; PKC-Z MI; PKWTC-S
A/AWT/AK	AC-S; AC-Z MI; AD-S; AD-U; AL-T; AL-W; AWT-C-S; AKC-S; AKC-Z MI; AKD-S; AKD-U; AKL-T; AKL-W
B/BK/BS/BCW/BWT	BC-S; BD-S; BD-U; BC-I; BL-W; BC-T MI; BKC-S; BKD-S; BKL-W; BKC-T MI; BSC-S; BCWB-S; BCWC-S; BWTC-S
C/CK/CX/CH/CS/CWT	CB-S; CC-S; CD-S; CC-T MI; CC- H MI; CKC-S; CKD-S; CKD-T MI; CXC-S; CXD-S; CHC-S; CHD-S; CSC-S; CWTC-S
NK/NK MI/NK 500 NH 500/NKS	NK-B-R; NK-C-R; NK-D-R; NK-C-R MI; NK-D-R MI; NH-B-R; NH-C-R; NH-D-R; NKS-C-R; NKS-B-R
VX/VX MI/VX6/VH VXX/ VXX MI/VXS	VX-A-R; VX-B-R; VX-C-R; VX-B-R MI; VX-A-R MI; VX-C-R MI; VX6-A-TS 1C; VH-B-R; VXX-B-R; VXX-F-R; VXX-B-R MI; VXX-F-R MI; VXS-B-R
VY	VY-B-R; VY-F-R; VY-C-R; VY-D-R
HX/HXR/HXR MI HXSR	HX-A-R; HXR-C-R; HXR-D-R, HXR-M-R; HXR-C-R MI; HXR-D-R MI, HXR-M-R MI, HXSR-C-DS
PENTA/PENTA 600	PENTA-B-R; PENTA-C-R; PENTA-D-R
GAMMA 62/3P/6P GAMMA-IL 3P/6P	GAMMA 62 TS 1C; GAMMA 85 TS 1C; GAMMA 85 TS 2C; GAMMA 105 TS 1C; GAMMA 105 TS 2C; GAMMA 125 TS 1C; GAMMA 125 TS 2C; GAMMA 155 TS 2C; GAMMA 162 TS 1C; GAMMA 162 TS 2C; GAMMA 202 TS 1C; GAMMA 202 TS 2C; GAMMA 242 TS 1C; GAMMA 242 TS 2C GAMMA-IL 83 TS 1C; GAMMA-IL 103 TS 1C; GAMMA-IL 160 TS 1C; GAMMA-IL 200 TS 1C

# ANNEX B

## NOZZLES TABLE

		PRESSIONE / PRESSURE [l/min - PSI]																		
TPO TYPE	bar	20	30	40	50	60	70	80	90	100	110	120	130	140	150	160	170	180	190	200
	PSI	290	435	580	725	870	1015	1160	1305	1450	1595	1740	1885	2031	2176	2321	2466	2611	2756	2901
	Ø mm	PORTATA / FLOW RATE [l/min - GPM]																		
015	0,8	1,5	1,9	2,2	2,4	2,6	2,9	3,1	3,2	3,4	3,6	3,7	3,9	4,0	4,2	4,3	4,5	4,6	4,7	4,8
		0,4	0,5	0,6	0,6	0,7	0,8	0,8	0,9	0,9	0,9	1,0	1,0	1,1	1,1	1,1	1,2	1,2	1,2	1,3
02	0,91	2,0	2,5	2,9	3,2	3,5	3,8	4,1	4,3	4,6	4,8	5,0	5,2	5,4	5,6	5,8	5,9	6,1	6,3	6,4
		0,5	0,7	0,8	0,9	0,9	1,0	1,1	1,1	1,2	1,3	1,3	1,4	1,4	1,5	1,5	1,6	1,6	1,7	1,7
025	1	2,5	3,1	3,6	4,0	4,4	4,8	5,1	5,4	5,7	6,0	6,2	6,5	6,7	7,0	7,2	7,4	7,6	7,8	8,0
		0,7	0,8	1,0	1,1	1,2	1,3	1,3	1,4	1,5	1,6	1,6	1,7	1,8	1,8	1,9	2,0	2,0	2,1	2,1
03	1,09	3,1	3,7	4,3	4,8	5,3	5,7	6,1	6,5	6,8	7,2	7,5	7,8	8,1	8,4	8,6	8,9	9,2	9,4	9,7
		0,8	1,0	1,1	1,3	1,4	1,5	1,6	1,7	1,8	1,9	2,0	2,1	2,1	2,2	2,3	2,4	2,4	2,5	2,6
035	1,15	3,6	4,4	5,0	5,6	6,2	6,7	7,1	7,6	8,0	8,4	8,7	9,1	9,4	9,8	10,1	10,4	10,7	11,0	11,3
		0,9	1,2	1,3	1,5	1,6	1,8	1,9	2,0	2,1	2,2	2,3	2,4	2,5	2,6	2,7	2,7	2,8	2,9	3,0
04	1,19	4,1	5,0	5,8	6,4	7,1	7,6	8,1	8,6	9,1	9,5	10,0	10,4	10,8	11,2	11,5	11,9	12,2	12,6	12,9
		1,1	1,3	1,5	1,7	1,9	2,0	2,2	2,3	2,4	2,5	2,6	2,7	2,8	2,9	3,0	3,1	3,2	3,3	3,4
045	1,27	4,6	5,6	6,5	7,2	7,9	8,6	9,2	9,7	10,2	10,7	11,2	11,7	12,1	12,5	13,0	13,4	13,7	14,1	14,5
		1,2	1,5	1,7	1,9	2,1	2,3	2,4	2,6	2,7	2,8	3,0	3,1	3,2	3,3	3,4	3,5	3,6	3,7	3,8
05	1,35	5,1	6,2	7,2	8,0	8,8	9,5	10,2	10,8	11,4	11,9	12,5	13,0	13,5	13,9	14,4	14,8	15,3	15,7	16,1
		1,3	1,6	1,9	2,1	2,3	2,5	2,7	2,9	3,0	3,2	3,3	3,4	3,6	3,7	3,8	3,9	4,0	4,1	4,3
055	1,4	5,6	6,9	7,9	8,9	9,7	10,5	11,2	11,9	12,5	13,1	13,7	14,3	14,8	15,3	15,8	16,3	16,8	17,3	17,7
		1,5	1,8	2,1	2,3	2,6	2,8	3,0	3,1	3,3	3,5	3,6	3,8	3,9	4,1	4,2	4,3	4,4	4,6	4,7
06	1,47	6,1	7,5	8,6	9,7	10,6	11,4	12,2	13,0	13,7	14,3	15,0	15,6	16,2	16,7	17,3	17,8	18,3	18,8	19,3
		1,6	2,0	2,3	2,6	2,8	3,0	3,2	3,4	3,6	3,8	4,0	4,1	4,3	4,4	4,6	4,7	4,8	5,0	5,1
065	1,52	6,6	8,1	9,4	10,5	11,5	12,4	13,2	14,0	14,8	15,5	16,2	16,9	17,5	18,1	18,7	19,3	19,9	20,4	20,9
		1,7	2,1	2,5	2,8	3,0	3,3	3,5	3,7	3,9	4,1	4,3	4,5	4,6	4,8	4,9	5,1	5,2	5,4	5,5
07	1,6	7,1	8,7	10,1	11,3	12,3	13,3	14,3	15,1	15,9	16,7	17,5	18,2	18,9	19,5	20,2	20,8	21,4	22,0	22,5
		1,9	2,3	2,7	3,0	3,3	3,5	3,8	4,0	4,2	4,4	4,6	4,8	5,0	5,2	5,3	5,5	5,6	5,8	6,0
075	1,65	7,6	9,4	10,8	12,1	13,2	14,3	15,3	16,2	17,1	17,9	18,7	19,5	20,2	20,9	21,6	22,3	22,9	23,5	24,1
		2,0	2,5	2,9	3,2	3,5	3,8	4,0	4,3	4,5	4,7	4,9	5,1	5,3	5,5	5,7	5,9	6,1	6,2	6,4
08	1,7	8,1	10,0	11,5	12,9	14,1	15,2	16,3	17,3	18,2	19,1	19,9	20,8	21,5	22,3	23,0	23,7	24,4	25,1	25,8
		2,2	2,6	3,0	3,4	3,7	4,0	4,3	4,6	4,8	5,0	5,3	5,5	5,7	5,9	6,1	6,3	6,5	6,6	6,8
085	1,75	8,7	10,6	12,2	13,7	15,0	16,2	17,3	18,4	19,3	20,3	21,2	22,1	22,9	23,7	24,5	25,2	26,0	26,7	27,4
		2,3	2,8	3,2	3,6	4,0	4,3	4,6	4,8	5,1	5,4	5,6	5,8	6,0	6,3	6,5	6,7	6,9	7,0	7,2
09	1,8	9,2	11,2	13,0	14,5	15,9	17,1	18,3	19,4	20,5	21,5	22,4	23,4	24,2	25,1	25,9	26,7	27,5	28,2	29,0
		2,4	3,0	3,4	3,8	4,2	4,5	4,8	5,1	5,4	5,7	5,9	6,2	6,4	6,6	6,8	7,1	7,3	7,5	7,7
095	1,85	9,7	11,8	13,7	15,3	16,8	18,1	19,3	20,5	21,6	22,7	23,7	24,7	25,6	26,5	27,4	28,2	29,0	29,8	30,6
		2,6	3,1	3,6	4,0	4,4	4,8	5,1	5,4	5,7	6,0	6,3	6,5	6,8	7,0	7,2	7,4	7,7	7,9	8,1
10	1,9	10,2	12,5	14,4	16,1	17,6	19,0	20,4	21,6	22,8	23,9	24,9	26,0	26,9	27,9	28,8	29,7	30,5	31,4	32,2
		2,7	3,3	3,8	4,3	4,7	5,0	5,4	5,7	6,0	6,3	6,6	6,9	7,1	7,4	7,6	7,8	8,1	8,3	8,5
105	1,94	10,7	13,1	15,1	16,9	18,5	20,0	21,4	22,7	23,9	25,1	26,2	27,3	28,3	29,3	30,2	31,2	32,1	32,9	33,8
		2,8	3,5	4,0	4,5	4,9	5,3	5,6	6,0	6,3	6,6	6,9	7,2	7,5	7,7	8,0	8,2	8,5	8,7	8,9
11	1,98	11,2	13,7	15,8	17,7	19,4	20,9	22,4	23,8	25,0	26,3	27,4	28,5	29,6	30,7	31,7	32,6	33,6	34,5	35,4
		3,0	3,6	4,2	4,7	5,1	5,5	5,9	6,3	6,6	6,9	7,2	7,5	7,8	8,1	8,4	8,6	8,9	9,1	9,4
115	2,03	11,7	14,3	16,6	18,5	20,3	21,9	23,4	24,8	26,2	27,5	28,7	29,8	31,0	32,1	33,1	34,1	35,1	36,1	37,0
		3,1	3,8	4,4	4,9	5,4	5,8	6,2	6,6	6,9	7,3	7,6	7,9	8,2	8,5	8,7	9,0	9,3	9,5	9,8
12	2,08	12,2	15,0	17,3	19,3	21,2	22,9	24,4	25,9	27,3	28,6	29,9	31,1	32,3	33,5	34,6	35,6	36,6	37,7	38,6
		3,2	4,0	4,6	5,1	5,6	6,0	6,5	6,8	7,2	7,6	7,9	8,2	8,5	8,8	9,1	9,4	9,7	9,9	10,2
125	2,13	12,7	15,6	18,0	20,1	22,0	23,8	25,4	27,0	28,5	29,8	31,2	32,4	33,7	34,8	36,0	37,1	38,2	39,2	40,2
		3,4	4,1	4,8	5,3	5,8	6,3	6,7	7,1	7,5	7,9	8,2	8,6	8,9	9,2	9,5	9,8	10,1	10,4	10,6
13	2,16	13,2	16,2	18,7	20,9	22,9	24,8	26,5	28,1	29,6	31,0	32,4	33,7	35,0	36,2	37,4	38,6	39,7	40,8	41,8
		3,5	4,3	4,9	5,5	6,1	6,5	7,0	7,4	7,8	8,2	8,6	8,9	9,2	9,6	9,9	10,2	10,5	10,8	11,1
14	2,26	14,3	17,5	20,2	22,5	24,7	26,7	28,5	30,2	31,9	33,4	34,9	36,3	37,7	39,0	40,3	41,6	42,8	43,9	45,1
		3,8	4,6	5,3	6,0	6,5	7,0	7,5	8,0	8,4	8,8	9,2	9,6	10,0	10,3	10,6	11,0	11,3	11,6	11,9
15	2,34	15,3	18,7	21,6	24,1	26,4	28,6	30,5	32,4	34,1	35,8	37,4	38,9	40,4	41,8	43,2	44,5	45,8	47,1	48,3
		4,0	4,9	5,7	6,4	7,0	7,5	8,1	8,6	9,0	9,5	9,9	10,3	10,7	11,0	11,4	11,8	12,1	12,4	12,8
16	2,41	16,3	19,9	23,0	25,8	28,2	30,5	32,6	34,6	36,4	38,2	39,9	41,5	43,1	44,6	46,1	47,5	48,9	50,2	51,5
		4,3	5,3	6,1	6,8	7,5	8,0	8,6	9,1	9,6	10,1	10,5	11,0	11,4	11,8	12,2	12,5	12,9	13,3	13,6
18	2,54	18,3	22,4	25,9	29,0	31,7	34,3	36,6	38,9	41,0	43,0	44,9	46,7	48,5	50,2	51,8	53,4	55,0	56,5	57,9
		4,8	5,9	6,8	7,7	8,4	9,1	9,7	10,3	10,8	11,4	11,9	12,3	12,8	13,3	13,7	14,1	14,5	14,9	15,3
20	2,69	20,4	24,9	28,8	32,2	35,3	38,1	40,7	43,2	45,5	47,7	49,9	51,9	53,9	55,8	57,6	59,4	61,1	62,8	64,4
		5,4	6,6	7,6	8,5	9,3	10,1	10,8	11,4	12,0	12,6	13,2	13,7	14,2	14,7	15,2	15,7	16,1	16,6	17,0
25	3	25,4	31,2	36,0	40,2	44,1	47,6	50,9	54,0	56,9	59,7	62,3	64,9	67,3	69,7	72,0	74,2	76,3	78,4	80,5
		6,7	8,2	9,5	10,6	11,6	12,6	13,4	14,3	15,0	15,8	16,5	17,1	17,8	18,4	19,0	19,6	20,2	20,7	21,3
30	3,3	30,5	37,4	43,2	48,3	52,9	57,1	61,1	64,8	68,3	71,6	74,8	77,9	80,8	83,6	86,4	89,0	91,6	94,1	96,6
		8,1	9,9	11,4	12,8	14,0	15,1	16,1	17,1	18,0	18,9	19,8	20,6	21,3	22,1	22,8	23,5	24,2	24,9	25,5
40	3,8	40,7	49,9	57,6	64,4	70,5	76,2	81,4	86,4	91,1	95,5	99,7	103,8	107,7	111,5	115,2	118,7	122,2	125,5	128,8
		10,8	13,2	15,2	17,0	18,6	20,1	21,5	22,8	24,1	25,2	26,3	27,4	28,5	29,5	30,4	31,4	32,3	33,2	34,0
50	4,2	50,9	62,3	72,0	80,5	88,2	95,2	101,8	108,0	113,8	119,4	124,7	129,8	134,7	139,4	144,0	148,4	152,7		

		PRESSIONE / PRESSURE [l/min - PSI]																		
TIPO TYPE	bar	210	220	230	240	250	280	300	350	400	450	500	550	600	700	800	900	1000	1100	1250
	PSI Q	3046	3191	3336	3481	3626	4061	4351	5076	5802	6527	7252	7977	8702	10153	11603	13053	14504	15954	18130
		PORTATA / FLOW RATE [l/min - GPM]																		
	Ø mm																			
015	0,8	4,9	5,1	5,2	5,3	5,4	5,7	5,9	6,4	6,8	7,2	7,6	8,0	8,4	9,0	9,7	10,2	10,8	11,3	12,1
		1,3	1,3	1,4	1,4	1,4	1,5	1,6	1,7	1,8	1,9	2,0	2,1	2,2	2,4	2,6	2,7	2,9	3,0	3,2
02	0,91	6,6	6,8	6,9	7,1	7,2	7,6	7,9	8,5	9,1	9,7	10,2	10,7	11,2	12,0	12,9	13,7	14,4	15,1	16,1
		1,7	1,8	1,8	1,9	1,9	2,0	2,1	2,2	2,4	2,6	2,7	2,8	2,9	3,2	3,4	3,6	3,8	4,0	4,3
025	1	8,2	8,4	8,6	8,8	9,0	9,5	9,9	10,6	11,4	12,1	12,7	13,3	13,9	15,1	16,1	17,1	18,0	18,9	20,1
		2,2	2,2	2,3	2,3	2,4	2,5	2,6	2,8	3,0	3,2	3,4	3,5	3,7	4,0	4,3	4,5	4,8	5,0	5,3
03	1,09	9,9	10,1	10,4	10,6	10,8	11,4	11,8	12,8	13,7	14,5	15,3	16,0	16,7	18,1	19,3	20,5	21,6	22,6	24,1
		2,6	2,7	2,7	2,8	2,9	3,0	3,1	3,4	3,6	3,8	4,0	4,2	4,4	4,8	5,1	5,4	5,7	6,0	6,4
035	1,15	11,5	11,8	12,1	12,3	12,6	13,3	13,8	14,9	15,9	16,9	17,8	18,7	19,5	21,1	22,5	23,9	25,2	26,4	28,2
		3,0	3,1	3,2	3,3	3,3	3,5	3,6	3,9	4,2	4,5	4,7	4,9	5,2	5,6	6,0	6,3	6,7	7,0	7,4
04	1,19	13,2	13,5	13,8	14,1	14,4	15,2	15,8	17,0	18,2	19,3	20,4	21,4	22,3	24,1	25,8	27,3	28,8	30,2	32,2
		3,5	3,6	3,6	3,7	3,8	4,0	4,2	4,5	4,8	5,1	5,4	5,6	5,9	6,4	6,8	7,2	7,6	8,0	8,5
045	1,27	14,8	15,2	15,5	15,9	16,2	17,1	17,7	19,2	20,5	21,7	22,9	24,0	25,1	27,1	29,0	30,7	32,4	34,0	36,2
		3,9	4,0	4,1	4,2	4,3	4,5	4,7	5,1	5,4	5,7	6,1	6,3	6,6	7,2	7,7	8,1	8,6	9,0	9,6
05	1,35	16,5	16,9	17,3	17,6	18,0	19,0	19,7	21,3	22,8	24,1	25,4	26,7	27,9	30,1	32,2	34,1	36,0	37,7	40,2
		4,4	4,5	4,6	4,7	4,8	5,0	5,2	5,6	6,0	6,4	6,7	7,1	7,4	8,0	8,5	9,0	9,5	10,0	10,6
055	1,4	18,1	18,6	19,0	19,4	19,8	20,9	21,7	23,4	25,0	26,6	28,0	29,4	30,7	33,1	35,4	37,6	39,6	41,5	44,3
		4,8	4,9	5,0	5,1	5,2	5,5	5,7	6,2	6,6	7,0	7,4	7,8	8,1	8,8	9,4	9,9	10,5	11,0	11,7
06	1,47	19,8	20,3	20,7	21,2	21,6	22,9	23,7	25,6	27,3	29,0	30,5	32,0	33,5	36,1	38,6	41,0	43,2	45,3	48,3
		5,2	5,4	5,5	5,6	5,7	6,0	6,2	6,7	7,2	7,7	8,1	8,5	8,8	9,5	10,2	10,8	11,4	12,0	12,8
065	1,52	21,4	21,9	22,4	22,9	23,4	24,8	25,6	27,7	29,6	31,4	33,1	34,7	36,2	39,1	41,8	44,4	46,8	49,1	52,3
		5,7	5,8	5,9	6,1	6,2	6,5	6,8	7,3	7,8	8,3	8,7	9,2	9,6	10,3	11,1	11,7	12,4	13,0	13,8
07	1,6	23,1	23,6	24,2	24,7	25,2	26,7	27,6	29,8	31,9	33,8	35,6	37,4	39,0	42,2	45,1	47,8	50,4	52,8	56,3
		6,1	6,2	6,4	6,5	6,7	7,0	7,3	7,9	8,4	8,9	9,4	9,9	10,3	11,1	11,9	12,6	13,3	14,0	14,9
075	1,65	24,7	25,3	25,9	26,4	27,0	28,6	29,6	31,9	34,1	36,2	38,2	40,0	41,8	45,2	48,3	51,2	54,0	56,6	60,4
		6,5	6,7	6,8	7,0	7,1	7,5	7,8	8,4	9,0	9,6	10,1	10,6	11,0	11,9	12,8	13,5	14,3	15,0	15,9
08	1,7	26,4	27,0	27,6	28,2	28,8	30,5	31,5	34,1	36,4	38,6	40,7	42,7	44,6	48,2	51,5	54,6	57,6	60,4	64,4
		7,0	7,1	7,3	7,5	7,6	8,0	8,3	9,0	9,6	10,2	10,8	11,3	11,8	12,7	13,6	14,4	15,2	16,0	17,0
085	1,75	28,0	28,7	29,3	30,0	30,6	32,4	33,5	36,2	38,7	41,0	43,3	45,4	47,4	51,2	54,7	58,0	61,2	64,2	68,4
		7,4	7,6	7,8	7,9	8,1	8,6	8,9	9,6	10,2	10,8	11,4	12,0	12,5	13,5	14,5	15,3	16,2	17,0	18,1
09	1,8	29,7	30,4	31,1	31,7	32,4	34,3	35,5	38,3	41,0	43,5	45,8	48,0	50,2	54,2	57,9	61,5	64,8	67,9	72,4
		7,8	8,0	8,2	8,4	8,6	9,1	9,4	10,1	10,8	11,5	12,1	12,7	13,3	14,3	15,3	16,2	17,1	17,9	19,1
095	1,85	31,3	32,1	32,8	33,5	34,2	36,2	37,5	40,5	43,2	45,9	48,4	50,7	53,0	57,2	61,2	64,9	68,4	71,7	76,5
		8,3	8,5	8,7	8,8	9,0	9,6	9,9	10,7	11,4	12,1	12,8	13,4	14,0	15,1	16,2	17,1	18,1	18,9	20,2
10	1,9	33,0	33,8	34,5	35,3	36,0	38,1	39,4	42,6	45,5	48,3	50,9	53,4	55,8	60,2	64,4	68,3	72,0	75,5	80,5
		8,7	8,9	9,1	9,3	9,5	10,1	10,4	11,2	12,0	12,8	13,4	14,1	14,7	15,9	17,0	18,0	19,0	19,9	21,3
105	1,94	34,6	35,5	36,2	37,0	37,8	40,0	41,4	44,7	47,8	50,7	53,4	56,1	58,5	63,2	67,6	71,7	75,6	79,3	84,5
		9,1	9,4	9,6	9,8	10,0	10,6	10,9	11,8	12,6	13,4	14,1	14,8	15,5	16,7	17,9	18,9	20,0	20,9	22,3
11	1,98	36,3	37,1	38,0	38,8	39,6	41,9	43,4	46,8	50,1	53,1	56,0	58,7	61,3	66,2	70,8	75,1	79,2	83,0	88,5
		9,6	9,8	10,0	10,2	10,5	11,1	11,5	12,4	13,2	14,0	14,8	15,5	16,2	17,5	18,7	19,8	20,9	21,9	23,4
115	2,03	37,9	38,8	39,7	40,6	41,4	43,8	45,3	49,0	52,4	55,5	58,5	61,4	64,1	69,3	74,0	78,5	82,8	86,8	92,5
		10,0	10,3	10,5	10,7	10,9	11,6	12,0	12,9	13,8	14,7	15,5	16,2	16,9	18,3	19,6	20,7	21,9	22,9	24,4
12	2,08	39,6	40,5	41,4	42,3	43,2	45,7	47,3	51,1	54,6	57,9	61,1	64,1	66,9	72,3	77,3	81,9	86,4	90,6	96,6
		10,5	10,7	10,9	11,2	11,4	12,1	12,5	13,5	14,4	15,3	16,1	16,9	17,7	19,1	20,4	21,6	22,8	23,9	25,5
125	2,13	41,2	42,2	43,2	44,1	45,0	47,6	49,3	53,2	56,9	60,4	63,6	66,7	69,7	75,3	80,5	85,4	90,0	94,4	100,6
		10,9	11,1	11,4	11,6	11,9	12,6	13,0	14,1	15,0	15,9	16,8	17,6	18,4	19,9	21,3	22,5	23,8	24,9	26,6
13	2,16	42,9	43,9	44,9	45,8	46,8	49,5	51,3	55,4	59,2	62,8	66,2	69,4	72,5	78,3	83,7	88,8	93,6	98,1	104,6
		11,3	11,6	11,9	12,1	12,4	13,1	13,5	14,6	15,6	16,6	17,5	18,3	19,1	20,7	22,1	23,5	24,7	25,9	27,6
14	2,26	46,2	47,3	48,3	49,4	50,4	53,3	55,2	59,6	63,7	67,6	71,3	74,7	78,1	84,3	90,1	95,6	100,8	105,7	112,7
		12,2	12,5	12,8	13,0	13,3	14,1	14,6	15,7	16,8	17,9	18,8	19,7	20,6	22,3	23,8	25,3	26,6	27,9	29,8
15	2,34	49,5	50,6	51,8	52,9	54,0	57,1	59,1	63,9	68,3	72,4	76,3	80,1	83,6	90,3	96,6	102,4	108,0	113,2	120,7
		13,1	13,4	13,7	14,0	14,3	15,1	15,6	16,9	18,0	19,1	20,2	21,2	22,1	23,9	25,5	27,1	28,5	29,9	31,9
16	2,41	52,8	54,0	55,2	56,4	57,6	60,9	63,1	68,1	72,8	77,3	81,4	85,4	89,2	96,4	103,0	109,3	115,2	120,8	128,8
		13,9	14,3	14,6	14,9	15,2	16,1	16,7	18,0	19,2	20,4	21,5	22,6	23,6	25,5	27,2	28,9	30,4	31,9	34,0
18	2,54	59,4	60,8	62,1	63,5	64,8	68,6	71,0	76,7	81,9	86,9	91,6	96,1	100,4	108,4	115,9	122,9	129,6	135,9	144,9
		15,7	16,1	16,4	16,8	17,1	18,1	18,7	20,2	21,6	23,0	24,2	25,4	26,5	28,6	30,6	32,5	34,2	35,9	38,3
20	2,69	66,0	67,5	69,0	70,5	72,0	76,2	78,9	85,2	91,1	96,6	101,8	106,8	111,5	120,4	128,8	136,6	144,0	151,0	161,0
		17,4	17,8	18,2	18,6	19,0	20,1	20,8	22,5	24,1	25,5	26,9	28,2	29,5	31,8	34,0	36,1	38,0	39,9	42,5
25	3	82,5	84,4	86,3	88,2	90,0	95,2	98,6	106,5	113,8	120,7	127,2	133,5	139,4	150,6	161,0	170,7	180,0	188,7	201,2
		21,8	22,3	22,8	23,3	23,8	25,2	26,0	28,1	30,1	31,9	33,6	35,3	36,8	39,8	42,5	45,1	47,5	49,9	53,1
30	3,3	99,0	101,3	103,6	105,8	108,0	114,3	118,3	127,8	136,6	144,9	152,7	160,1	167,3	180,7	193,1	204,9	215,9	226,5	241,4
		26,1	26,8	27,4	27,9	28,5	30,2	31,2	33,7	36,1	38,3	40,3	42,3	44,2	47,7	51,0	54,1	57,0	59,8	63,8
40	3,8	131,9	135,0	138,1	141,1	144,0	152,4	157,7	170,3	182,1	193,1									

# ANNEX C

## TECHNICAL DATA SHEETS

PN	S – Albero MASCHIO Ø24 mm DESTRO S – MALE Shaft Ø24 mm RIGHT	Z – Albero CAVO 5/8" DESTRO Z - HOLLOW Shaft 5/8" RIGHT	PN
273100 – 959800 – 959900 – 950600 – 950200 – 950700 - 949700 - 271000 – 951100 – 950500 – 951300 – 949200 - 949600 – 950000			700033 – 700034 – 952000 – 952400 – 952200 – 952700
271200 - 959700			955400 – 953900 – 955500
956700			<b>PK</b> 272800 – 917600 – 917500 – 917400 – 916700 – 270700 – 274800 – 271500

PK	U – Albero CAVO 1" 1/8 DESTRO U – HOLLOW Shaft 1" 1/8 RIGHT	T – Albero CAVO 3/4" DESTRO T – HOLLOW Shaft 3/4" RIGHT	PK
917000			710003
PK	W – Albero CAVO 1" DESTRO W – HOLLOW Shaft 1" RIGHT	Z MI – Albero CAVO 5/8" DESTRO Z MI – HOLLOW Shaft 5/8" RIGHT	PK
917300 – 917200 – 917100		271400	
A	S – Albero MASCHIO Ø24 mm DESTRO S – MALE Shaft Ø24 mm RIGHT	U – Albero CAVO 1" 1/8 DESTRO U – HOLLOW Shaft 1" 1/8 RIGHT	A
720012 - 720013 - 720014 - 720042 - 720015 - 720001 - 720044 - 720016 - 720018 - 720017			720004 - 720010

A	T – Albero CAVO 3/4" DESTRO T – HOLLOW Shaft 3/4" RIGHT	W – Albero CAVO 1" DESTRO W – HOLLOW Shaft 1" RIGHT	A
720029 - 720006 - 720028			720030 - 720031 - 720007
A	Z MI – Albero CAVO 5/8" DESTRO Z MI – HOLLOW Shaft 5/8" RIGHT	S – Albero MASCHIO Ø24 mm DESTRO S – MALE Shaft Ø24 mm RIGHT	AK
720005		720002 - 720019 - 720020 - 720021 - 720022 - 720023 - 720024 - 720025 - 720043	
AK	U – Albero CAVO 1" 1/8 DESTRO U – HOLLOW Shaft 1" 1/8 RIGHT	T – Albero CAVO 3/4" DESTRO T – HOLLOW Shaft 3/4" RIGHT	AK
720010			720011

AK	W – Albero CAVO 1" DESTRO W – HOLLOW Shaft 1" RIGHT	Z MI – Albero CAVO 5/8" DESTRO Z MI – HOLLOW Shaft 5/8" RIGHT	AK
720003 - 720027 - 720040 - 720041			720009
B	S – Albero MASCHIO Ø24 mm DESTRO S – MALE Shaft Ø24 mm RIGHT	U – Albero CAVO 1" 1/8 DESTRO U – HOLLOW Shaft 1" 1/8 RIGHT	B
905200 – 908000 – 905700 – 906100 – 907900 – 905000 – 427700 – 905300 – 905400 – 905800 – 909300			907700 – 907800 – 907600
B	I – Albero CAVO Ø28 mm DESTRO I – HOLLOW Shaft Ø28 mm RIGHT	W – Albero CAVO 1" DESTRO W – HOLLOW Shaft 1" RIGHT	B
906600 – 906700 – 425700			907200 – 907400

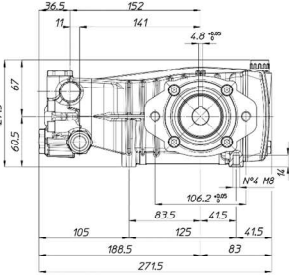
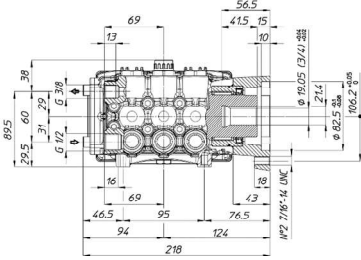
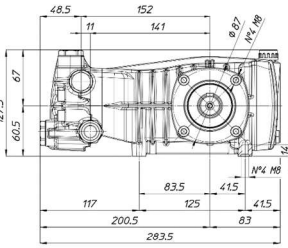
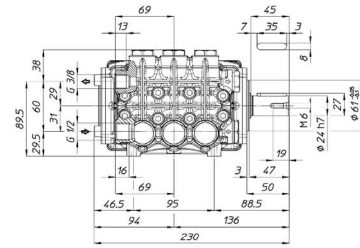
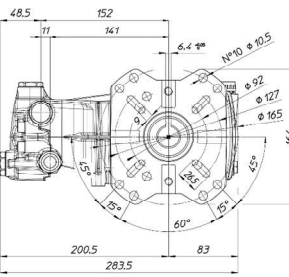
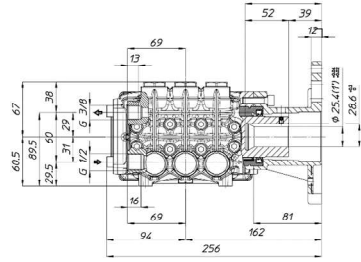
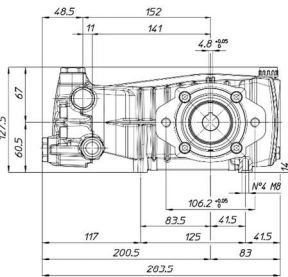
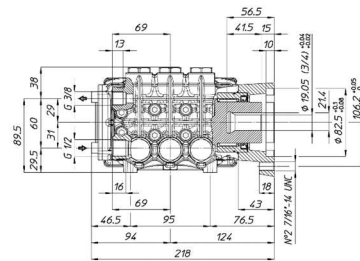
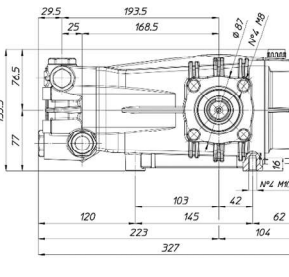
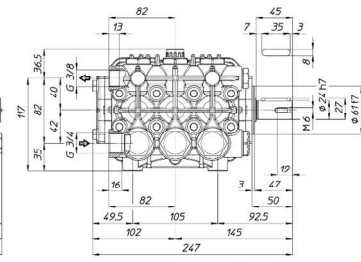
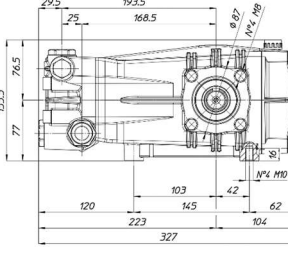
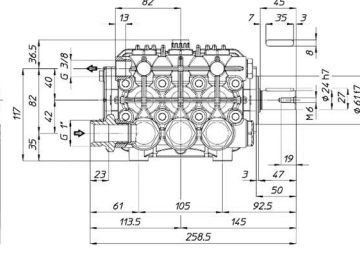
B	T MI – Albero CAVO 3/4" DESTRO T MI – HOLLOW Shaft 3/4" RIGHT	S – Albero MASCHIO Ø24 mm DESTRO S – MALE Shaft Ø24 mm RIGHT	BK
428500 – 428600		905500 – 906000 – 905900 – 906200 – 906400 – 425200 – 909800	
 		 	
BK	W – Albero CAVO 1" DESTRO W – HOLLOW Shaft 1" RIGHT	T MI – Albero CAVO 3/4" DESTRO T MI – HOLLOW Shaft 3/4" RIGHT	BK
907000 – 907100 – 907500		429800 – 429900	
 		 	
C	S – Albero MASCHIO Ø24 mm DESTRO S – MALE Shaft Ø24 mm RIGHT	S – Albero MASCHIO Ø24 mm DESTRO S – MALE Shaft Ø24 mm RIGHT	C
900100 – 901200 – 901500 – 900000 – 900800 – 902100 – 901300 – 902200 – 901700		902300 – 900600 – 900700	
 		 	

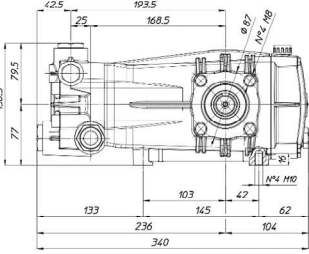
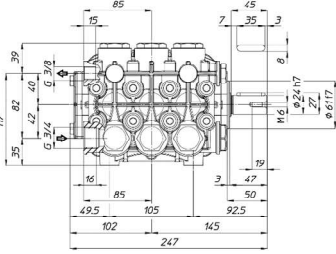
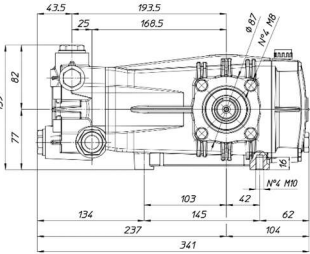
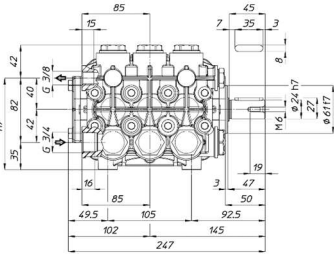
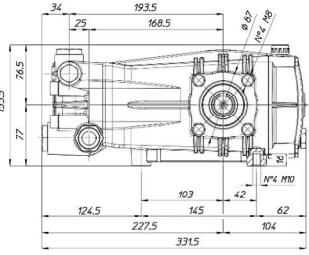
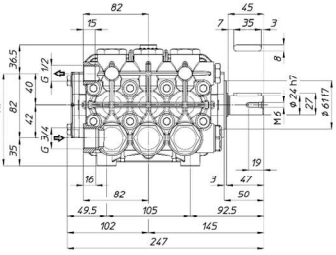
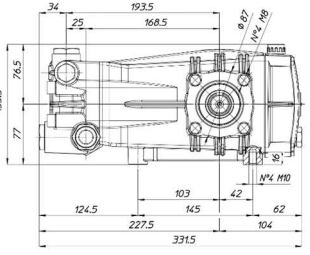
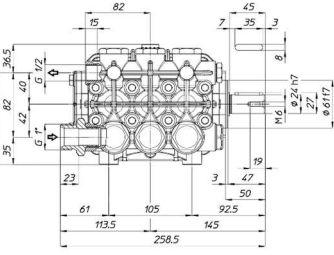
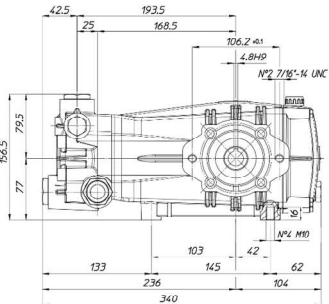
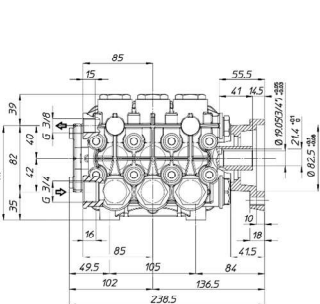
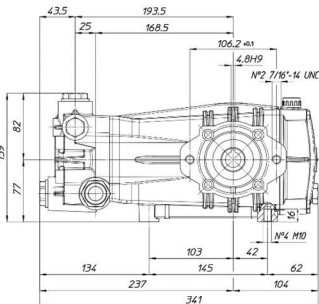
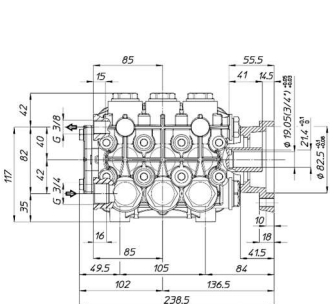

CK	S – Albero MASCHIO Ø24 mm DESTRO S – MALE Shaft Ø24 mm RIGHT	S – Albero MASCHIO Ø24 mm DESTRO S – MALE Shaft Ø24 mm RIGHT	CK
294000 – 294200 – 294600 – 740015 – 294400		291600 – 290000 – 292100 – 292400 – 292600 – 291800 – 291900 – 295500 – 295600 - 295700	
 		 	
CK	S – Albero MASCHIO Ø24 mm DESTRO S – MALE Shaft Ø24 mm RIGHT	S – Albero MASCHIO Ø24 mm DESTRO S – MALE Shaft Ø24 mm RIGHT	CK
292700		293000 – 293400 - 295800	
 		 	
CK	T MI – Albero CAVO 3/4" DESTRO T MI – HOLLOW Shaft 3/4" RIGHT	T MI – Albero CAVO 3/4" DESTRO T MI – HOLLOW Shaft 3/4" RIGHT	CK
299300		299400 – 299500	
 		 	

CX	S – Albero MASCHIO Ø24 mm DESTRO S – MALE Shaft Ø24 mm RIGHT	S – Albero MASCHIO Ø24 mm DESTRO S – MALE Shaft Ø24 mm RIGHT	CH
294800 – 294900 – 295000 -298500 – 298600 – 298700			291000 – 290200 – 291300 – 291200 – 290400
NK	R – Albero MASCHIO Ø30 mm DESTRO R – MALE Shaft Ø30 mm RIGHT	R – Albero MASCHIO Ø30 mm DESTRO R – MALE Shaft Ø30 mm RIGHT	NK
878000 – 878200 – 877900 – 878500 – 878400 – 875900 – 876000 – 875100 – 876100 – 875200 – 878100 – 878300 – 750012		878800 – 878600 – 879000 – 876200 – 875300 – 875400 – 878900 – 878700	
NK	R – Albero MASCHIO Ø30 mm DESTRO R – MALE Shaft Ø30 mm RIGHT	R MI - Albero 13T 16/32 DP - SAE B - DESTRO R MI - Shaft 13T 16/32 DP - SAE B - RIGHT	NK
879100 – 879400 – 875500		877800 – 320000 – 320100 – 320200 – 320400	

NK	R MI - Albero 13T 16/32 DP - SAE B - DESTRO R MI - Shaft 13T 16/32 DP - SAE B - RIGHT	R MI - Albero 13T 16/32 DP - SAE B - DESTRO R MI - Shaft 13T 16/32 DP - SAE B - RIGHT	NK
877400 – 877500 – 877600 – 320500 – 320600			320300 – 877700
NK 500	R – Albero MASCHIO Ø30 mm DESTRO R – MALE Shaft Ø30 mm RIGHT	R – Albero MASCHIO Ø30 mm DESTRO R – MALE Shaft Ø30 mm RIGHT	NH 500
879200 – 879300 – 817900 – 878000 – 750002 – 750001			750010 – 750011 – 750003 – 750004 -750006 – 750005
GAMMA 62	TS 1C / TS 2C / TS GR TS 1C / TS 2C / TS GR	TS 1C / TS 2C TS 1C / TS 2C	GAMMA 3P
837700 – 837600 – 837800			838200 – 838100 – 838700 – 838600 – 839200 – 839100

GAMMA 3P	TS 2C (1" 3/8 Scanalato – 1" 3/8 Scanalato) TS 2C (1" 3/8 Splined – 1" 3/8 Splined)	TS 1C / TS 2C TS 1C / TS 2C	GAMMA 6P
817200	839700 – 839600 – 837200 – 837100 – 840200 – 840100		
GAMMA-IL 3P	TS 1C (Ø35 – 1" 3/8 Scanalato) TS 1C (Ø35 – 1" 3/8 Splined)	TS 1C (Ø35 – 1" 3/8 Scanalato) TS 1C (Ø35 – 1" 3/8 Splined)	GAMMA-IL 6P
832100 – 832600	833100 – 833600		
PENTA	R – Albero MASCHIO Ø35 mm DESTRO R – MALE Shaft Ø35 mm RIGHT	R – Albero MASCHIO Ø35 mm DESTRO R – MALE Shaft Ø35 mm RIGHT	PENTA
880900 – 880700 – 880800 – 880600	880500 – 880300 – 883000 – 880100 – 880400 – 880200 – 882600 – 880000		

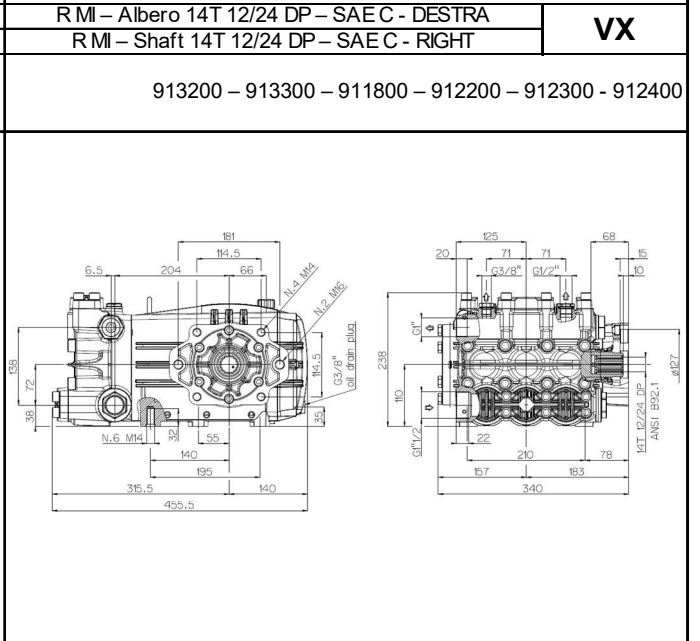
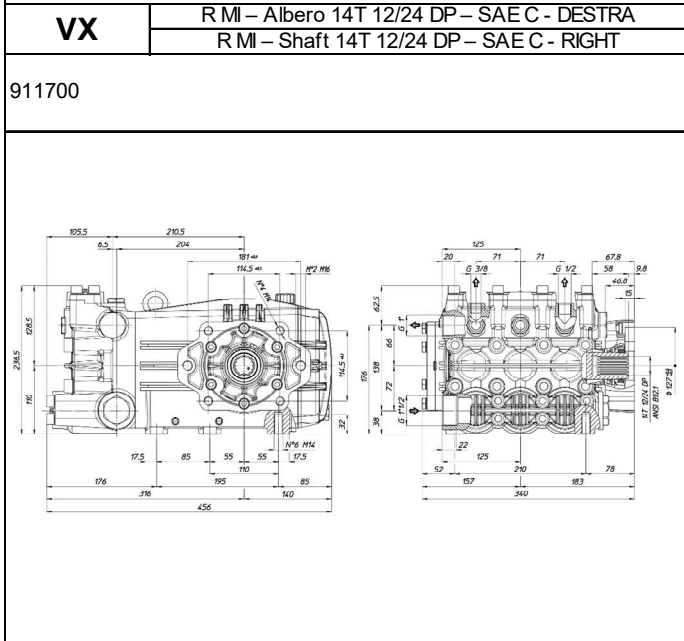
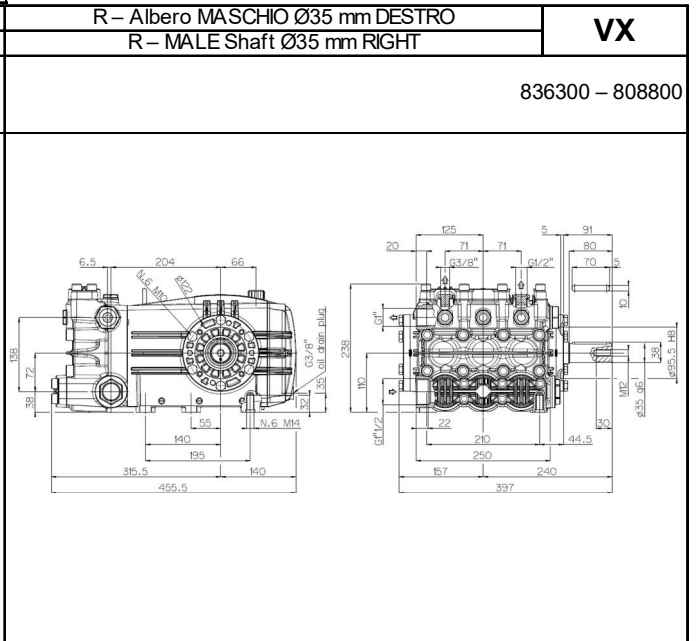
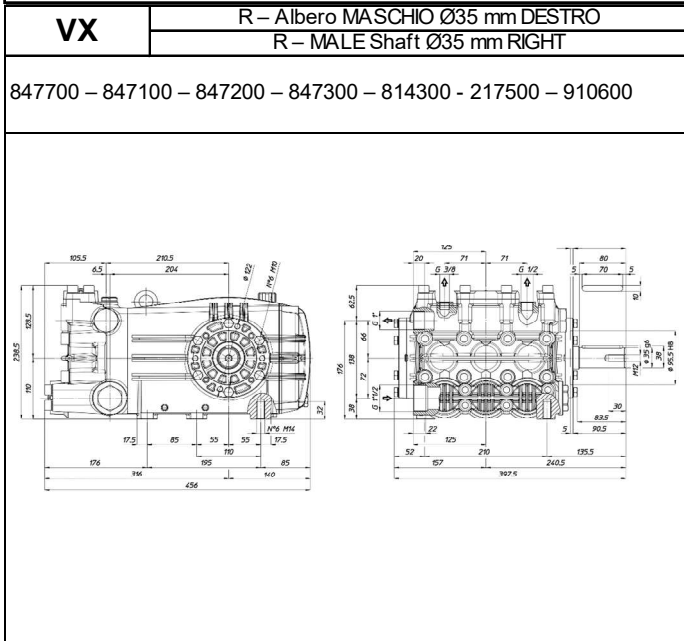
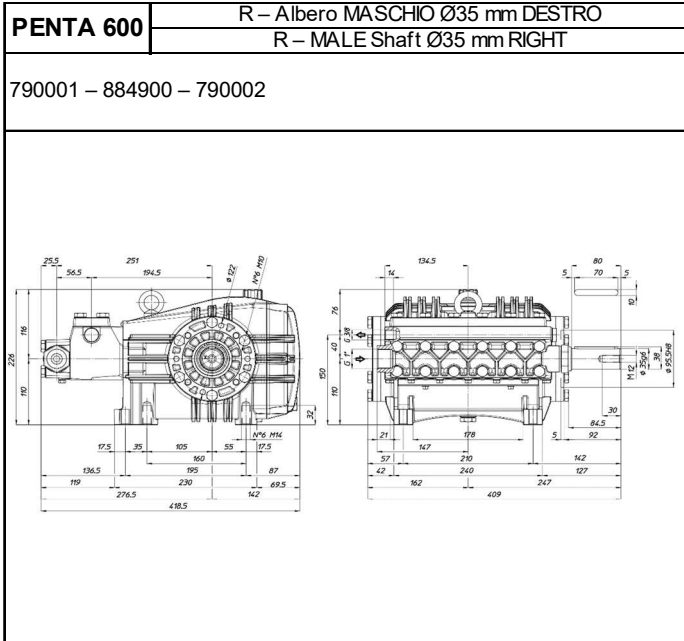

<b>VX6</b>	TS 1C – Ø35 – 1”3/8 SCANALATO TS 1C – Ø35 – 1”3/8 SPLINED	R – Albero MASCHIO Ø35 mm DESTRO R – MALE Shaft Ø35 mm RIGHT	<b>VH</b>
915500 – 915400 – 915300		834700	
<b>VXX</b>	R – Albero MASCHIO Ø40 mm DESTRO R – MALE Shaft Ø40 mm RIGHT	R MI – Albero 14T 12/24 DP – SAEC - DESTRA R MI – Shaft 14T 12/24 DP – SAEC - RIGHT	<b>VXX</b>
800003 – 910800 – 911000 – 911200 – 800007		800004 – 912700 – 912800 – 912900 – 913000	
S – Albero MASCHIO Ø24 mm DESTRO S – MALE Shaft Ø24 mm RIGHT		<b>PS</b>	
270600 – 700042 – 915800 – 915900			

PS	Z – Albero CAVO 5/8" DESTRO Z – HOLLOW Shaft 5/8" RIGHT	S – Albero MASCHIO Ø24 mm DESTRO S – MALE Shaft Ø24 mm RIGHT	BS
700010 – 700011 – 700012 – 700013 – 700014			730004 – 730003 – 730002
CS	S – Albero MASCHIO Ø24 mm DESTRO S – MALE Shaft Ø24 mm RIGHT	R – Albero MASCHIO Ø30 mm DESTRO R – MALE Shaft Ø30 mm RIGHT	NKS
620000 – 620100 – 620200 – 620300			876300 – 876400 – 876500
NKS	R – Albero MASCHIO Ø30 mm DESTRO R – MALE Shaft Ø30 mm RIGHT	R – Albero MASCHIO Ø35 mm DESTRO R – MALE Shaft Ø35 mm RIGHT	VXS
872100 – 879900			818800 – 818900 – 819000

BCW	S – Albero MASCHIO Ø24 mm DESTRO S – MALE Shaft Ø24 mm RIGHT	S – Albero MASCHIO Ø24 mm DESTRO S – MALE Shaft Ø24 mm RIGHT	PKWT
730067 – 730056 – 730066 – 730049 – 730048 – 730045 – 730051 – 730052			270300 – 270200 – 710026
BWT	S – Albero MASCHIO Ø24 mm DESTRO S – MALE Shaft Ø24 mm RIGHT	S – Albero MASCHIO Ø24 mm DESTRO S – MALE Shaft Ø24 mm RIGHT	CWT
429700 – 429600 – 429500			904500 – 740029 – 904400
CWT	S – Albero MASCHIO Ø24 mm DESTRO S – MALE Shaft Ø24 mm RIGHT	S – Albero MASCHIO Ø24 mm DESTRO S – MALE Shaft Ø24 mm RIGHT	CWT
904600 – 904700			740009

# ANNEX D

## ENGINE COUPLING SYSTEMS

ACCOPIAMENTI DISPONIBILI PER MOTORI ELETTRICI  
COUPLINGS AVAILABLE FOR ELECTRIC MOTORS

P04	MOTORE ELETTRICO B3/B14 Gr.90 ELECTRIC MOTOR B3/B14 Gr.90	MOTORE ELETTRICO B3/B14 Gr.100/112 ELECTRIC MOTOR B3/B14 Gr.100/112	P05
Pompe serie PN-PS Pump series PN-PS		Pompe serie PN-PS Pump series PN-PS	
PK08	MOTORE ELETTRICO B3/B14 Gr.100/112 ELECTRIC MOTOR B3/B14 Gr.100/112	MOTORE ELETTRICO B3/B14 Gr.100/112 ELECTRIC MOTOR B3/B14 Gr.100/112	BC04
Pompe serie PK-PKWT-A-AK-AWT Pump series PK-PKWT-A-AK-AWT		Pompe serie B-BS-BWT-BK-C-CS-CWT-CK-CX-CH Pump series B-BS-BWT-BK-C-CS-CWT-CK-CX-CH	
BC05	MOTORE ELETTRICO NEMA 182T/184T ELECTRIC MOTOR NEMA 182T/184T	MOTORE ELETTRICO B3/B14 Gr.132 ELECTRIC MOTOR B3/B14 Gr.132	BC10
Pompe serie B-BS-BWT-BK-C-CS-CWT-CK-CX-CH Pump series B-BS-BWT-BK-C-CS-CWT-CK-CX-CH		Pompe serie B-BS-BWT-BK-C-CS-CWT-CK Pump series B-BS-BWT-BK-C-CS-CWT-CK	

<b>C14</b>	MOTORE ELETTRICO B3/B5 Gr.160	MOTORE ELETTRICO B3/B5 Gr.160	<b>NK01</b>
	ELECTRIC MOTOR B3/B5 Gr.160	ELECTRIC MOTOR B3/B5 Gr.160	
Pompe serie C-CS-CWT-CK-CX-CH		Pompe serie NK	
Pompe serie C-CS-CWT-CK-CX-CH		Pump series NK	
<b>NK02</b>	MOTORE ELETTRICO B3/B5 Gr.180	MOTORE ELETTRICO B3/B5 Gr.200	<b>NK03</b>
	ELECTRIC MOTOR B3/B5 Gr.180	ELECTRIC MOTOR B3/B5 Gr.200	
Pompe serie NK		Pompe serie NK-NKS	
Pump series NK		Pump series NK-NKS	
<b>VX01</b>	MOTORE ELETTRICO B3/B5 Gr.180	MOTORE ELETTRICO B3/B5 Gr.200	<b>VX02</b>
	ELECTRIC MOTOR B3/B5 Gr.180	ELECTRIC MOTOR B3/B5 Gr.200	
Pompe serie PENTA-VX-VY		Pompe serie B-BS-BWT-BK-C-CS-CWT-CK-CX-CH	
Pump series PENTA-VX-VY		Pump series B-BS-BWT-BK-C-CS-CWT-CK-CX-CH	

ACCOPIAMENTI DISPONIBILI PER MOTORI IDRAULICI  
COUPLINGS AVAILABLE FOR HYDRAULIC MOTORS

CI04	MOTORE IDRAULICO SAE "A" Gr. 2	MOTORE IDRAULICO SAE "B" Gr.3	CI03
	HYDRAULIC MOTOR SAE "A" Gr. 2	HYDRAULIC MOTOR SAE "B" Gr.3	
Pompe serie B-BK-C-CS-CWT-CK-CX-CH		Pompe serie C-CS-CWT-CK-CX-CH	
Pump series B-BK-C-CS-CWT-CK-CX-CH		Pump series C-CS-CWT-CK-CX-CH	
GMI01	MOTORE IDRAULICO ORBITALE SAE "A"	MOTORE IDRAULICO ORBITALE SAE "A"	GMI02
	HYDRAULIC ORBITAL MOTOR SAE "A"	HYDRAULIC ORBITAL MOTOR SAE "A"	
Pompe serie GAMMA62-GAMMA85/105/125		Pompe serie GAMMA62-GAMMA85/105/125	
Pump series GAMMA62-GAMMA85/105/125		Pump series GAMMA62-GAMMA85/105/125	

<b>GMI03</b>	<p>MOTORE IDRAULICO ORBITALE SAE "A" HYDRAULIC ORBITAL MOTOR SAE "A"</p>	<p>MOTORE IDRAULICO A PISTONI HYDRAULIC PISTON MOTOR</p>	<b>PTI01</b>
<p>Pompe serie GAMMA125/155- GAMMA162/202/242</p>		<p>Pompe serie PENTA</p>	
<p>Pompe serie GAMMA125/155-GAMMA162/202/242</p>		<p>Pump series PENTA</p>	
<b>VXI01</b>	<p>MOTORE IDRAULICO SAE J744-C HYDRAULIC MOTOR SAE J744-C</p>	<p>MOTORE IDRAULICO SAE J744-C HYDRAULIC MOTOR SAE J744-C</p>	<b>VXXI01</b>
<p>Pompe serie NK-NKS-VX-VXS-VH-VY-PENTA</p>		<p>Pompe serie VXX</p>	
<p>Pump series NK-NKS-VX-VXS-VH-VY-PENTA</p>		<p>Pump series VXX</p>	
<b>CI06</b>	<p>MOTORE IDRAULICO SAE J744-B HYDRAULIC MOTOR SAE J744-B</p>	<p>MOTORE IDRAULICO SAE J744-B HYDRAULIC MOTOR SAE J744-B</p>	<b>NKI01</b>
<p>Pompe serie C-CS-CWT-CK-CH</p>		<p>Pompe serie NK-NKS-NH</p>	
<p>Pompe serie C-CS-CWT-CK-CH</p>		<p>Pump series NK-NKS-NH</p>	

# ANNEX E

## TIGHTENING TORQUES

## TIGHTENING TORQUES

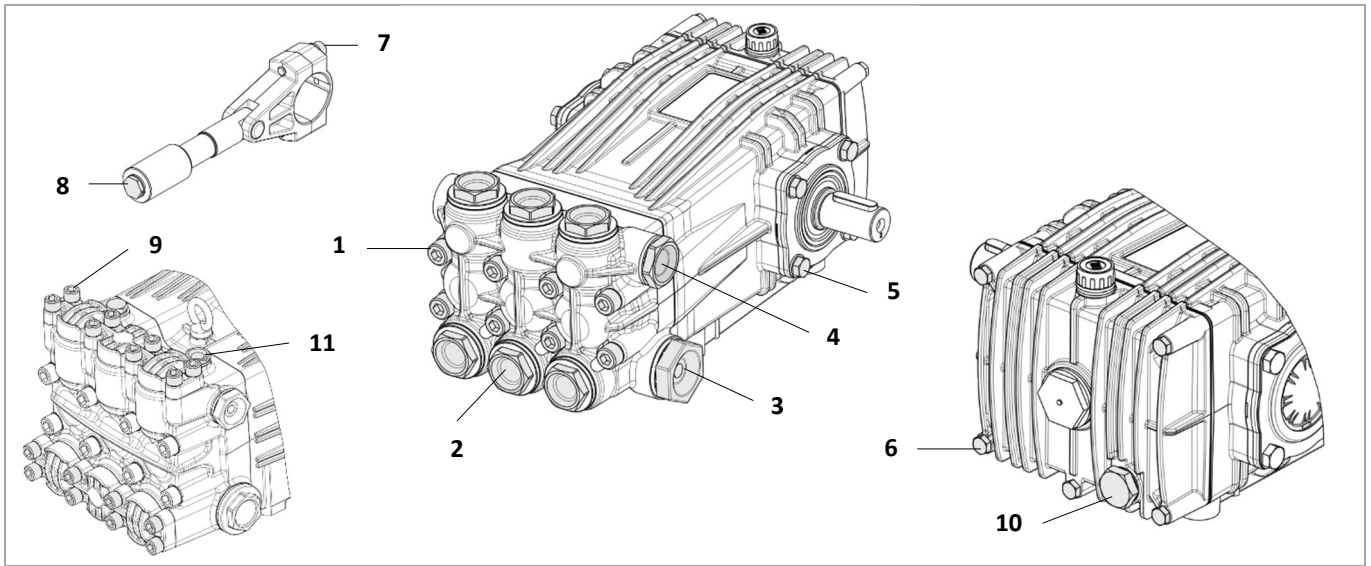

ITEM	DESCRIPTION	NOTE
1	Head Screws	Loctite® 243 - Threadlocker Medium Color: Light Blue
2	Valve Caps	
3	Inlet Cap	
4	Outlet plug	
5	Flange Bearing Screws	Loctite® 270 - Forte Threadlocker Color: Green
6	Rear Cover Screws	
7	Connecting rod screws	Loctite® 542 - Seals fittings medium strength Color: Red
8	Screw / Nut Plunger	
9	Valve Cover Screws	
10	Oil Plug	
11	Head service caps	

ITEM	PN				PK – PKWT – A – AWT				AK			
	d	N•m	lb•ft	Loctite®	d	N•m	lb•ft	Loctite®	d	N•m	lb•ft	Loctite®
1	M6	11	8	-	M6	11	8	-	M8	25	18	-
2	M22x1.5	100	74	243	M22x1.5	100	74	243	M22x1.5	100	74	243
3	G3/8	70	52	-	G1/2	70	52	-	G1/2	70	52	-
4	G3/8	70	52	-	G3/8	70	52	-	G3/8	70	52	-
5	-	-	-	-	-	-	-	-	-	-	-	-
6	M6	11	8	-	M6	11	8	-	M6	11	8	-
7	-	-	-	-	-	-	-	-	-	-	-	-
8	M8	15	11	243	M8	15	11	243	M8	15	11	243
9	-	-	-	-	-	-	-	-	-	-	-	-
10	G1/4	11	8	-	G1/4	11	8	-	G1/4	11	8	-
11	-	-	-	-	-	-	-	-	-	-	-	-
ITEM	B – BK – BCW – BWT				C (1)				C (2)			
	d	N•m	lb•ft	Loctite®	d	N•m	lb•ft	Loctite®	d	N•m	lb•ft	Loctite®
1	M8	25	18	-	M10	50	37	-	M10	50	37	-
2	M22x1.5	100	74	243	M27x1.5	140	103	243	M27x1.5	140	103	243
3	G1/2	70	52	-	G3/4	70	52	-	G3/4	70	52	-
4	G3/8	70	52	-	G3/8	70	52	-	G1/2	70	52	-
5	M8	25	18	-	M8	25	18	-	M8	25	18	-
6	M8	25	18	-	M6	11	8	-	M6	11	8	-
7	M6	11	8	243	M8	25	18	243	M8	25	18	243
8	M8	15	11	243	M8	20	15	243	M8	20	15	243
9	-	-	-	-	-	-	-	-	-	-	-	-
10	G1/4	11	8	-	G3/8	11	8	-	G3/8	11	8	-
11	-	-	-	-	-	-	-	-	-	-	-	-
(1) = CC 21/20 – CC 26/20 – CD 5.5/30 – CD 7.0/30 – CD 7.5/30 – CD 8.5/30 – CD 9.5/30 – CB 21/20 – CC 30/20 – CC 34/20 – CD 11.0/25 – CD 12.0/20 – CWTC 27/20 – CWTC 34/20												
(2) = CB 26/20 – CB 30/20 – CC 38/17 – CC 42/17 – CB 34/20 – CC 50/15 – CWTC 42/15 – CWTC 50/15												
(3) = CB 50/15 – CC 70/15 – CD 18.5/22 – CWTC 70/15												
ITEM	C (3)				CK (1)				CK (2)			
	d	N•m	lb•ft	Loctite®	d	N•m	lb•ft	Loctite®	d	N•m	lb•ft	Loctite®
1	M10	50	37	-	M10	50	37	-	M10	50	37	-
2	M30x1.5	180	133	243	M22x1.5	100	74	243	M30x1.5	180	133	243
3	G1	120	89	-	G3/4	70	52	-	G3/4	70	52	-
4	G3/4	70	52	-	G3/8	70	52	-	G3/8	70	52	-
5	M8	25	18	-	M8	25	18	-	M8	25	18	-
6	M6	11	8	-	M6	11	8	-	M6	11	8	-
7	M8	25	18	243	M8	25	18	243	M8	25	18	243
8	M8	20	15	243	M8	20	15	243	M8	20	15	243
9	-	-	-	-	-	-	-	-	-	-	-	-
10	G3/8	11	8	-	G3/8	11	8	-	G3/8	11	8	-
11	-	-	-	-	-	-	-	-	-	-	-	-
(1) = CKD 3.5/51 – CKC 17/36 – CKC 21/36 – CKD 4.5/51 – CKD 6.0/51												
(2) = CKC 17/30 – CKC 21/30 – CKC 26/30 – CKC 30/30 – CKD 5.5/44 – CKD 7.0/44 – CKC 34/25												
(3) = CKC 38/20 – CKC 42/20 – CKC 50/20												
ITEM	CK (3)				CX (1)				CH (2)			
	d	N•m	lb•ft	Loctite®	d	N•m	lb•ft	Loctite®	d	N•m	lb•ft	Loctite®
1	M10	50	37	-	M10	80	59	-	M10	80	59	-
2	M27x1.5	140	103	243	M22x1.5	100	74	243	-	-	-	-
3	G3/4	70	52	-	G3/4	70	52	-	G3/4	70	52	-
4	G1/2	70	52	-	G3/8	70	52	-	G3/8	70	52	-
5	M8	25	18	-	M8	25	18	-	M8	25	18	-
6	M6	11	8	-	M6	11	8	-	M6	11	8	-
7	M8	25	18	243	M8	25	18	243	M8	25	18	243
8	M8	20	15	243	M8	15	11	243	M8	15	11	243
9	-	-	-	-	-	-	-	-	M10	50	37	-
10	G3/8	11	8	-	G3/8	11	8	-	G3/8	11	8	-
11	-	-	-	-	-	-	-	-	-	-	-	-
(1) = CXC 15/50 – CXC 18/50 – CXC 22/50												
(2) = CHC 12/50 – CHC 16/50 – CHD 3.0/75 – CHD 4.5/75 – CHC 20/50												

ITEM	NK (1)				NK (2)				NK (3)			
	d	N•m	lb•ft	Loctite®	d	N•m	lb•ft	Loctite®	d	N•m	lb•ft	Loctite®
1	M10	50	37	-	M10	50	37	-	M10	50	37	-
2	M30x1.5	180	133	243	M36x1.5	180	133	243	M36x1.5	180	133	243
3	G1	140	103	-	G1 1/4	140	103	-	G1 1/4	140	103	-
4	G1/2	80	59	-	G3/4	80	59	-	G1	80	59	-
5	M10	50	37	-	M10	50	37	-	M10	50	37	-
6	M6	11	8	-	M6	11	8	-	M6	11	8	-
7	M8	25	18	243	M8	25	18	243	M8	25	18	243
8	M8	25	18	243	M8	25	18	243	M8	25	18	243
9	-	-	-	-	-	-	-	-	-	-	-	-
10	G3/8	11	8	-	G3/8	11	8	-	G3/8	11	8	-
11	-	-	-	-	-	-	-	-	-	-	-	-

(1) = NK-B 25/350 - NK-B 32/350 - NK-B 37/300 - NK-B 42/250 - NK-B 50/250 - NK-C 35/350 - NK-C 47/350 - NK-C 55/300 - NK-C 60/250 - NK-C 70/250 - NK-D 11.0/51 - NK-D 15.0/44  
(2) = NK-B 52/170 - NK-B 60/170 - NK-B 70/150 - NK-C 75/170 - NK-C 85/170 - NK-C 100/150 - NK-D 115/145 - NK-D 24.0/25 - NK-D 27.0/25  
(3) = NK-B 100/100 - NK-C 130/130 - NK-C 145/100

ITEM	VX - VXX (1)				VX - VXX -VH (2)				VX - VXX (3)			
	d	N•m	lb•ft	Loctite®	d	N•m	lb•ft	Loctite®	d	N•m	lb•ft	Loctite®
1	M14	200	148	-	M14	200	148	-	M14	200	148	-
2	-	-	-	-	-	-	-	-	-	-	-	-
3	G1 1/2	140	111	-	G1 1/2	140	111	-	G1 1/2	140	111	-
4	G1	140	89	-	G1	140	89	-	G1	140	89	-
5	M10	50	37	-	M10	50	37	-	M10	50	37	-
6	M6	11	8	-	M6	11	8	-	M6	11	8	-
7	M8	25	18	243	M8	25	19	243	M8	25	19	243
8	M10	50	37	243	M8	25	19	243	M12	50	37	243
9	M12	140	103	-	M12	140	103	-	M12	140	103	-
10	G3/8	11	8	-	G3/8	11	8	-	G3/8	11	8	-
11	G1/2 - G3/8	80	59	-	G1/2 - G3/8	80	59	-	G1/2 - G3/8	80	59	-

(1) = VX-B 100/200 - VX-B 130/160 - VX-B 160/130 - VX-C 135/160 - VX-D 140/130 - VX-D 150/80 - VX-C 115/110 - VX-C 150/80 - VXX-B 130/220 - VXX-B 160/180  
(2) = VX-C 100/200 - VX-B 60/350 - VX-B 75/280 - VX-C 95/140 - VX-D 90/140 - VH-B 40/600  
(3) = VX-A 161/110 - VX-B 200/100 - VXX-B 200/150 - VXX-F 230/140

ITEM	GAMMA 62				GAMMA 85/105/125/150 GAMMA-IL 83/103				GAMMA 162/202/242 GAMMA-IL 160/200 - VX6			
	d	N•m	lb•ft	Loctite®	d	N•m	lb•ft	Loctite®	d	N•m	lb•ft	Loctite®
1	M10	50	37	-	M12	80	59	-	M12	80	59	-
2	-	-	-	-	-	-	-	-	-	-	-	-
3	G1	120	89	-	G1	120	89	-	G1	120	89	-
4	G3/4	70	52	542	G3/4	70	52	542	G3/4	70	52	542
5	M10	50	37	-	M10	50	37	-	M10	50	37	-
6	M6	11	8	-	M6	11	8	-	M6	11	8	-
7	M8	25	18	243	M8	25	18	243	M8	25	18	243
8	M12	50	37	243	M14	65	48	243	M14	65	48	243
9	-	-	-	-	-	-	-	-	-	-	-	-
10	G3/8	11	8	-	G3/8	11	8	-	G3/8	11	8	-
11	-	-	-	-	-	-	-	-	-	-	-	-

ITEM	PENTA (1)				PENTA (2)				PENTA (3)			
	d	N•m	lb•ft	Loctite®	d	N•m	lb•ft	Loctite®	d	N•m	lb•ft	Loctite®
1	M10	50	37	-	M10	50	37	-	M10	50	37	-
2	M30x1.5	180	133	243	M30x1.5	180	133	243	-	-	-	-
3	G1	140	103	-	G1 1/4	140	103	-	G1	140	103	-
4	G1/2	80	59	-	G3/4	80	59	-	G3/8	80	59	-
5	M10	50	37	-	M10	50	37	-	M10	50	37	-
6	M6	11	8	-	M6	11	8	-	M6	11	8	-
7	M8	25	18	243	M8	25	18	243	M8	25	18	243
8	M8	20	15	243	M8	20	15	243	M8	15	11	243
9	-	-	-	-	-	-	-	-	M10	50	37	-
10	G3/8	11	8	-	G3/8	11	8	-	G3/8	11	8	-
11	-	-	-	-	-	-	-	-	-	-	-	-

(1) = PENTA-B 25/400 - PENTA-B 25/350 - PENTA-C 35/400 - PENTA-C 35/350  
(2) = PENTA-B 30/300 - PENTA-B 40/250 - PENTA-B 40/300 - PENTA-B 50/200 - PENTA-C 43/300 - PENTA-C 55/250 - PENTA-C 58/300 - PENTA-C 70/20  
(3) = PENTA-B 21/600 - PENTA-C 30/600 - PENTA-D 28/600

ITEM	PS				BS				CS			
	d	N•m	lb•ft	Loctite°	d	N•m	lb•ft	Loctite°	d	N•m	lb•ft	Loctite°
1	M6	11	8	-	M8	25	18	-	M10	50	37	-
2	M22x1.5	100	74	243	M22x1.5	100	74	243	M27x1.5	140	103	243
3	G1/2	70	52	-	G1/2	70	52	-	G3/4	70	52	-
4	G3/8	70	52	-	G3/8	70	52	-	G3/8	70	52	-
5	-	-	-	-	M8	25	18	-	M8	25	18	-
6	M6	11	8	-	M8	25	18	-	M6	11	8	-
7	-	-	-	-	M6	11	8	243	M8	25	18	243
8	M8	15	11	243	M8	15	11	243	M8	20	15	243
9	-	-	-	-	-	-	-	-	-	-	-	-
10	G1/4	11	8	-	G1/4	11	8	-	G3/8	11	8	-
11	-	-	-	-	-	-	-	-	-	-	-	-
ITEM	NKS (1)				NKS (2)				VXS			
	d	N•m	lb•ft	Loctite°	d	N•m	lb•ft	Loctite°	d	N•m	lb•ft	Loctite°
1	M10	50	37	-	M10	50	37	-	M14	140	148	-
2	M36x1.5	180	133	243	M36x1.5	180	133	243	-	-	-	-
3	G1 1/4	140	103	-	G1 1/4	140	103	-	G1 1/2	140	111	-
4	G3/4	80	59	-	G1	80	59	-	G1	140	89	-
5	M10	50	37	-	M10	50	37	-	M10	50	37	-
6	M6	11	8	-	M6	11	8	-	M6	11	8	-
7	M8	25	18	243	M8	25	18	243	M8	25	18	243
8	M8	25	18	243	M8	25	18	243	M10	50	37	243
9	-	-	-	-	-	-	-	-	M12	130	103	-
10	G3/8	11	8	-	G3/8	11	8	-	G3/8	11	8	-
11	-	-	-	-	-	-	-	-	G1/2 – G3/8	80	59	-

(1) = NKS-C 75/170 - NKS-C 85/170 - NKS-C 100/150

(2) = NKS-B 100/100 - NKS-C 145/100