

Il presente disegno è di proprietà di Interpump Group S.p.A., ne è vietata la riproduzione o la divulgazione a termini di legge. This drawing belongs to Interpump Group S.p.A., copy or divulgation are forbidden by law.

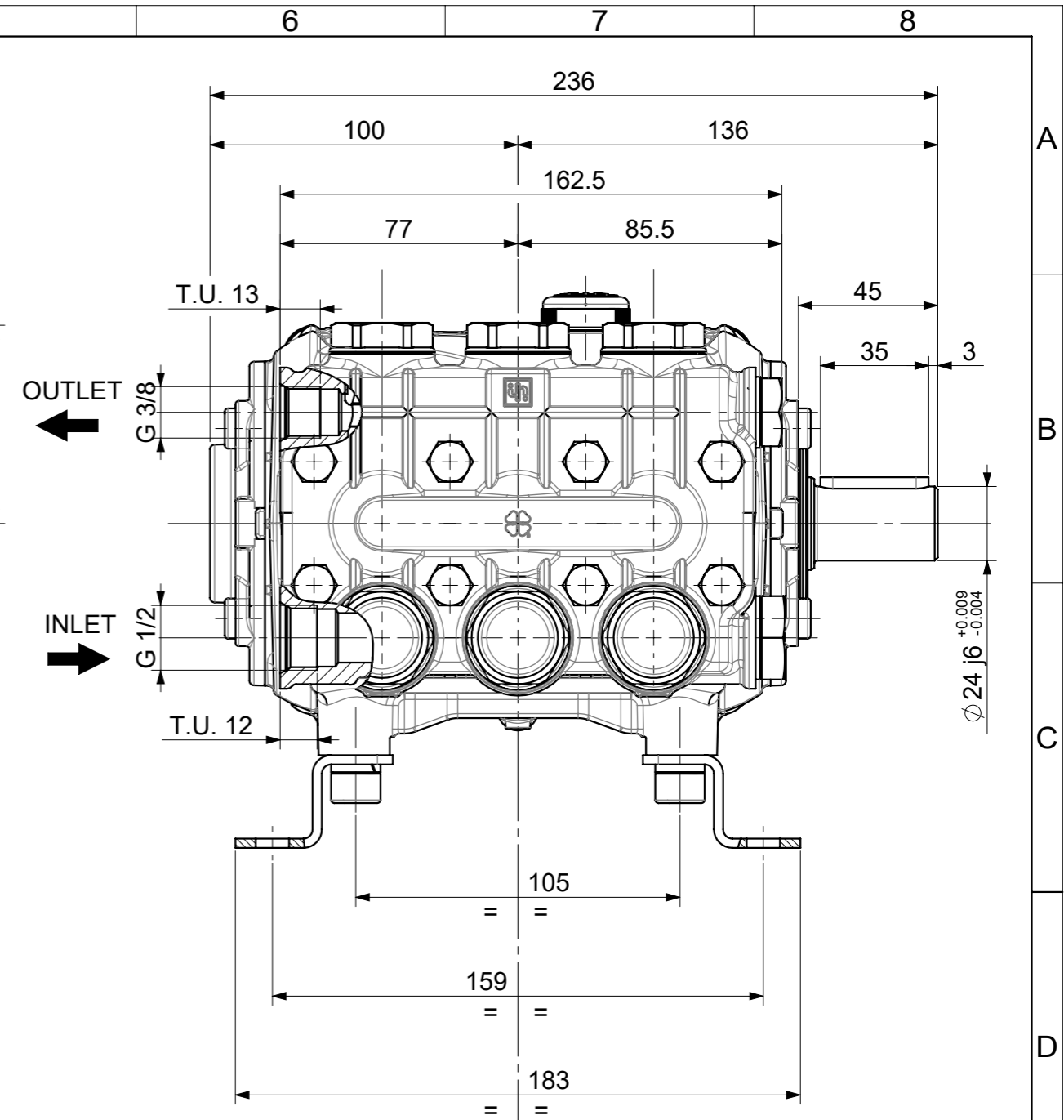
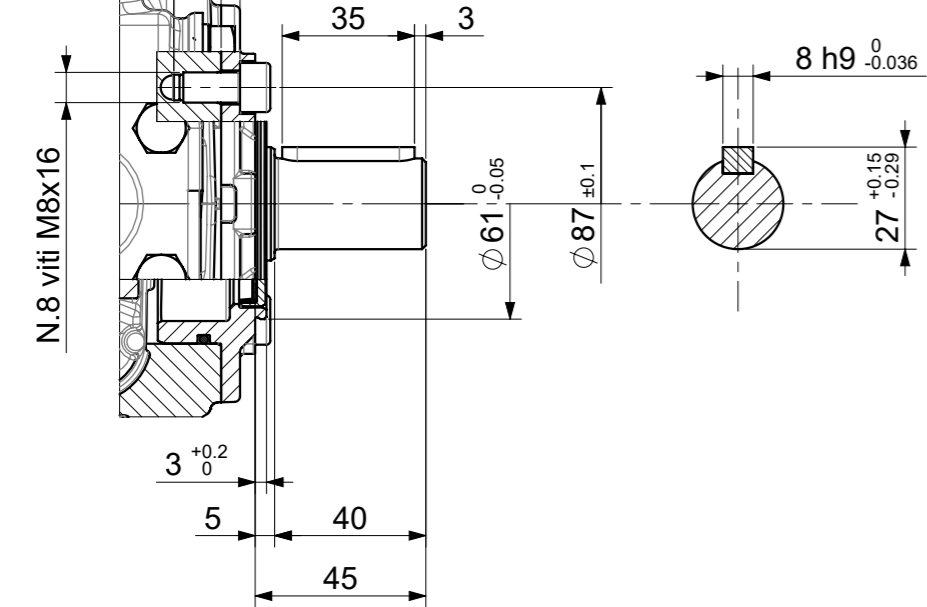
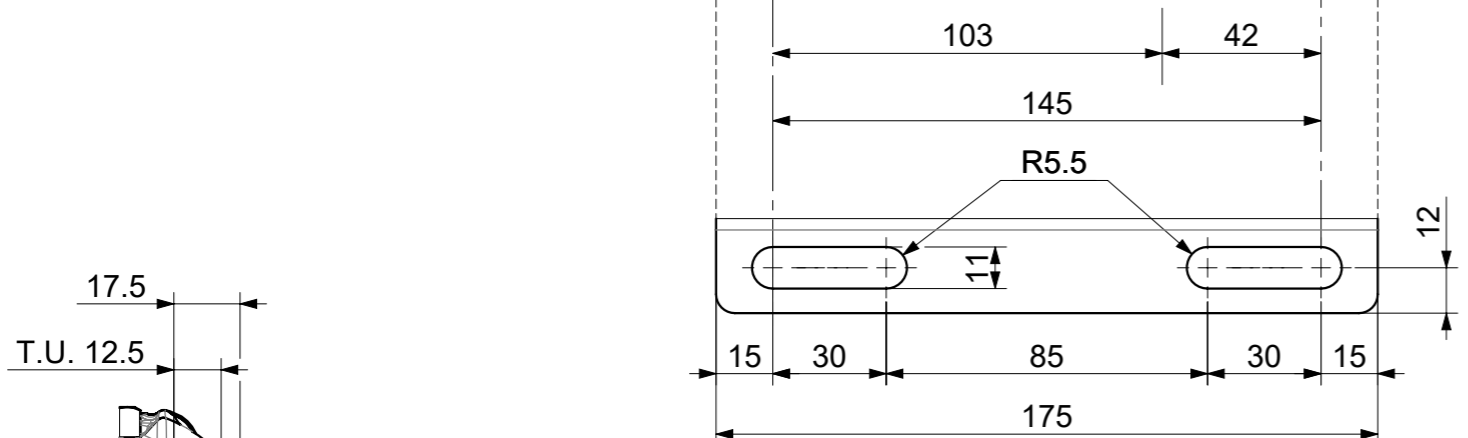
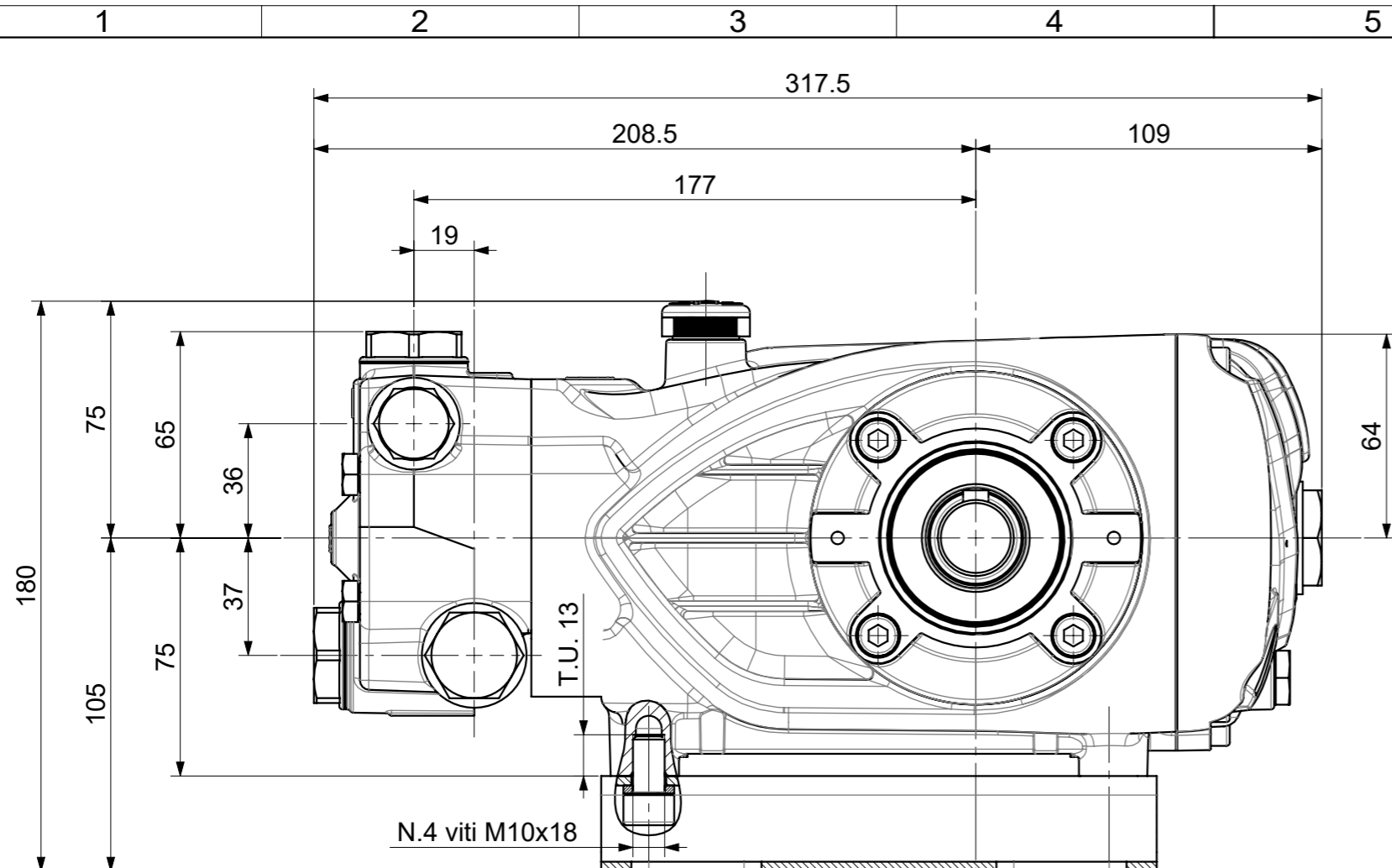

					ip		
REV.	Data/Date	Descrizione modifica / Modification description			Firma/Signature	MT N°	
DISEGN.:	FTECN.:	DATA:	SCALA: 1:1	Foglio: 1/1	Peso: 0 g	M.T.:	
DENOMINAZIONE / DENOMINATION					DIS. COD. / DRAWING CODE	REV.	
INGOMBRO POMPA SERIE 47 - USA S/FORO					47961700	0	
LEGENDA CRITICITA': vedi DT n°2850000082 CRITICALITY LEGEND: according to DT n.2850000082					Sicurezza Security	Critica Critical	
					Importante Important	Nessun simbolo No symbol	
					Standard	CRITICITA' NONE	