

P.A. – S.p.A. – EQUIPAGGIAMENTI TECNICI DEL LAVAGGIO

VIA MILANO, 13 – CASELLA POSTALE 115 – 42048 RUBIERA (REGGIO EMILIA) – ITALY
 Tel. +39 0522 623611 – Fax. +39 0522 629600 – R.E.A. RE 156319 – R.I. RE11535 – Mecc. RE 013446
 C.F. e P. IVA 01035950359 – Cap. Soc. i.v. € 750.000,00 – Codice Identificativo C.E.E. IT 01035950359
 ART. 2497 – BIS C.C. DIREZIONE E COORDINAMENTO BENETTI srl R.I. TRIB. DI RE 01480690351
 Web: <http://www.pa-etl.it> – E-mail: info@pa-etl.it



VB 10 - Unloader Valve (discharging)

Technical manual: E 212

Pressure regulating unloader valve with discharge control pressure with very low readings.
 At gun-lance closure, the water flow is bypassed at reduced pressure

DN 10

- **60.1100.00** VB 10 G3/8 FF
- **60.1100.50** VB 10 3/8NPT FF
- **60.1150.00** VB 10/2 G3/8 FF

- Sturdy steel and brass construction.
- Bypass control brought into effect by very low pressure readings. Therefore delivery line at reduced pressure at gun closure.
- Quick start at gun opening assures gradual pressure reset, essential for use on endothermic engines.
- Specially designed check valve prevents jamming and vibrations even in presence of sand and scale.
- Safety valve built in the delivery side.
- Working typology protected by registered patent.

Technical specifications

Max. flow rate: 30 l/min. Max temperature: 90°C (1)

Part number	Rated pressure bar - MPa	Permissible pressure bar - MPa	Minimum adjustable pressure bar - MPa	Pressure remainder at circuit closure		(2) Pressure drop to reset bypass bar			Inlet outlet bypass	Weight g
				> 150 bar > (15 MPa)	a 220 bar a (22 MPa)	100 (10)	150 (15)	200 (20)		
60.1100.00	220 - 22	250 - 25	22 – 2.2	45 (4.5)	55 (5.5)	15 (1.5)	20 (2)	30 (3)	G3/8 F	1100
60.1100.50	220 - 22	250 - 25	22 – 2.2	45 (4.5)	55 (5.5)	15 (1.5)	20 (2)	30 (3)	3/8 NPT F	1100
60.1150.00	220 - 22	250 - 25	22 – 2.2	45 (4.5)	55 (5.5)	15 (1.5)	20 (2)	30 (3)	G3/8 F	1200

(1) The valve has been designed for a continuous use at a water temperature of 60°C. It can resist for short periods at a maximum temperature of 90°C.

(2) This is the pressure reduction necessary in comparison to the set up, in order that the valve brings back pressure in the circuit.

Instruction manual, maintenance, installation, spare parts.	n. 12.9212.00
For a correct utilization, follow the directions of this manual	
Re-print them on the Use and Maintenance booklet of the machine.	

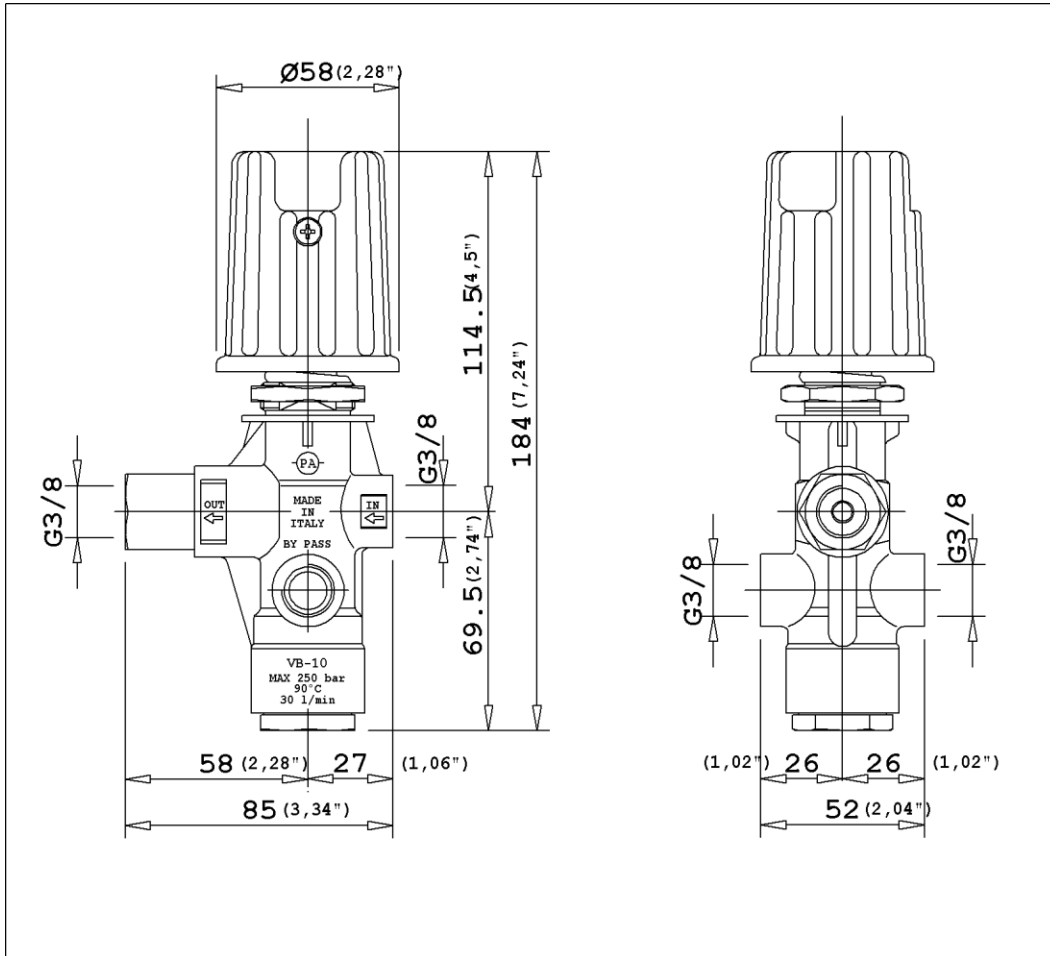
DIMENSIONAL DRAWING**INSTRUCTIONS****SELECTION**

This product is to be utilized with clean fresh water, even slightly additivated with normal detergents. For use involving different or corrosive liquids, contact the PA Technical department. Appropriate filtration should be installed when using unclean liquids. Choose the valve in line with the data of nominal running (system rated pressure, max flow and max temperature). In any case, the pressure of the machine should not exceed the permissible pressure rate imprinted on the valve.

INSTALLATION

This accessory, on a system that produces hot water, must be fitted in **front of the heat generator**. This product is bound to be incorporated on a finished machine. On a system that generates hot water, anticipate the fitting of accessories that limit the accidental increase of fluid temperature.

Always install a safety valve that protects the pressurized inlet channel.

Choose a correct nozzle size, which allows a regular discharge on bypass, at least 5% of the total flow of the system in order to achieve a constant pressure value and avoid troublesome pressure spikes at closure. If the nozzle wears out, the pressure drops.

On installation of a new nozzle, re-adjust the system to the original pressure setting.

OPERATIONS

The valve regulates the the max pressure of the system through a piston, which acts on a ball correctly positioned, that closes the bypass opening. A check valve cuts out the delivery section, the pressure of which controls the drive of the piston.

Each regulation should be made when the system is operational and the nozzle open.

ATTENTION: In order not to overstep the max pressure, the nut (pos 30) must be fastened and never removed otherwise a mechanical safety feature would lack that limits the max pressure avoiding serious damage to persons and machine. For the min pressure position the locknut (pos 33) on the nut (pos 34) blocking it with a dowel (pos 32). Mark the position with a drop of paint in order to prevent possible slackening and tampering.

The balanced conformation of the valve allows a renewed pressure at very low readings giving a longer function in bypass and a progressive restart, without unpleasant pressure spikes, useful with endothermic engines.

DISCHARGE SYSTEM AND WATER ADDUCTION

The bypass line should be returned into a tank with deflectors. By using a direct pump recycle, with elevated pressure intake, it is necessary to install a pressure reducer in order to have an even flow supply and to protect the circuit intake.

When the system is opened and closed frequently, it is recommended to install a thermal protector valve (VT3 or VT6) in order to eliminat excessive temperature build-up

PROBLEMS AND SOLUTIONS

PROBLEMS	PROBABLE CAUSES	SOLUTIONS
Frequent unloader recycles	Damaged seat or cone Leaking connections Restricted bypass	Replace Check and renew Clean or adapt
Unloader does not reach pressure	Unloader not properly sized Piston O rings worn out Material matter between seat and shutter Worn out nozzle	Change spring or type of valve Replace Clean the seat Replace
Pressure peaks	There is not a min of 5% of total flow in bypass Excessive flow in bypass Spring totally compressed	Reset Change type of valve or adjust passages Loosen knob and change nozzle
Unloader does not bypass at low pressure	Jammed check valve Check valve O ring worn out Material matter on check valve	Clean or replace Replace Clean

REGULATIONS : *see norm manual*

For a correct utilization, follow the directions described in this manual and re-print them on the Use and maintenance manual of the machine.

Make sure that you are given **the Original Conformity Declaration** for the accessory chosen. The present manual is valid for all unloader valves named **VB 10**.

MAINTENANCE

Maintenance has to be carried out by **Specialized Technicians**.

STANDARD: every 400 working hours (circa 10,000 cycles), check and lubricate the seals with water resistant grease.

SPECIAL: every 800 working hours (circa 20,000 cycles), control the wear of the seals and internal parts and if necessary, replace with original PA parts taking care during installation and to lubricate with water resistant grease.

ATTENTION: reassemble the valve in the correct manner paying special attention to the **Nut (pos 31)** which must always be in place.

The manufacturer is not to be considered responsible for damage as a result from incorrect fitting and maintenance

Technical data, descriptions and illustrations are indicative and liable to modification without notice.

60.1100.00 VB10 unload. 3/8F Bsp+knob

60.1100.50 VB10 unload. 3/8F Npt +knob

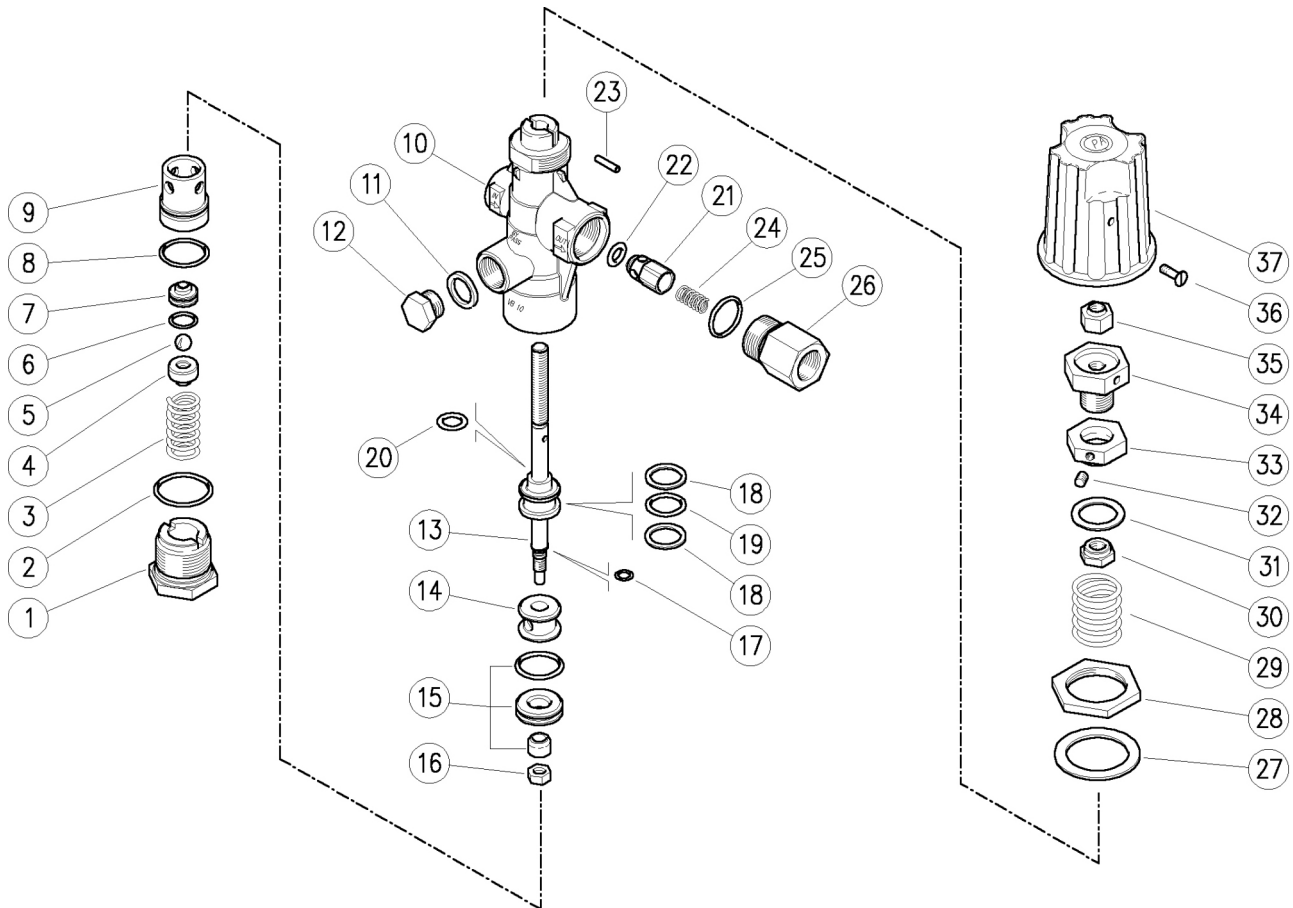

Pos.	P/N	Description	Q.ty	K1	K2	K3	K4	
1	60.1101.31R	Lower plug, M27x1,5 brass	1					3
2	10.3074.01R	O-ring, 1,78x25,12 mm Ni 85	1	•				10
3	60.1102.51R	Spring, 2,5x12,6x26 mm Sst.	1					10
4	60.1112.31R	Ball holding piston, brass	1					3
5	14.7421.50R	Ball, 1/4" Sst.	1	•				10
6	10.3059.01R	O-ring, 1,78x11,11 mm Ni 85	1	•				10
7	60.1103.51R	Seat, 5x14x7 mm Sst.	1	•				10
8	10.3072.01R	O-ring, 1,78x20,35 mm Ni 85	1	•				10
9	60.1107.31R	Spacer ring, 9x24x29 mm brass	1					3
10	60.1108.35R	Housing -VB10, 3/8 FFF Bsp brass (1)	1					3
10	60.1120.35R	Housing -VB10, 3/8 Npt FFF brass (2)	1					3
11	14.4042.00R	Washer, 16,7x22x1,5 mm alu. (1)	1					25
12	60.0028.31R	Plug,brass 3/8 Bsp,hex.19 (1)	1					25
12	60.0025.31R	Grub screw, brass 3/8M Npt (2)	1					10
13	60.1106.23R	Piston -VB10	1	•				3
14	60.1105.31R	Spacer ring, 8,5x20,8x14,5mm brs.	1					3
15	60.1116.24	Seat, 10mm+O-ring, 1,78mm+shutt.	1	•				1
16	11.4540.00R	Hex. nut, M6, Sst.	1					10
17	10.3001.01R	O-ring, 1x4 mm Ni 85	1	•				10
18	10.4056.00R	Back-up ring, opn. 15,5x19,9x2 mm	2	•				10

Pos.	P/N	Description	Q.ty	K1	K2	K3	K4	
19	10.3180.00R	O-ring, 2,62x15,08 mm	1	•				10
20	10.3170.08R	O-ring, 2,62x7,6 mm Ni 85	1	•				10
21	60.0052.99R	Shutter pin, brass+o-ring 3x6 mm	1					10
22	10.3213.00R	O-ring, 3x6 mm	1	•				10
23	15.1021.00R	Roll pin, 3x14 mm Sst.	1					10
24	60.0053.51R	Spring, 0,7x9x20 mm Sst.	1					10
25	10.3070.02R	O-ring, 1,78x18,77 mm Ni 85	1	•				10
26	60.0058.31R	Delivery coupl., 3/8F Bsp brass (1)	1					5
26	60.0059.31R	Delivery coupl., 3/8F Npt brass (2)	1					10
27	14.3582.00R	Washer, 30,5x42x2 mm	1					10
28	60.2254.31R	Ring nut, M30 brass	1					10
29	60.2203.61R	Spring, 4,2x27,4x31 mm z.pl.	1					10
30	60.2207.31R	Ring nut, M8 brass	1					10
31	60.2208.84R	Washer, 19x26x1,5 mm PA black	1					10
32	16.2105.00R	Set screw, DIN913 M5x6 mm	1					10
33	60.2252.31R	Ring nut, M16x1 brass	1					10
34	60.2253.31R	Regulating pin, brass	1					10
35	11.4589.10R	Hex. locknut, M8	1					10
36	16.1838.00R	Screw, DIN7985 M4x10 mm z.pl.	1					10
37	60.2251.84R	Valve regulating knob, PA black	1					5

Kit	P/N	Description	Q.ty
K1	60.1115.24	Spare kit -VB10, 14x1pcs.	1

(1) 60.1100.00 (2) 60.1100.50

60.1150.00 VB10 unload. 3/8F Bsp +sst.pist.

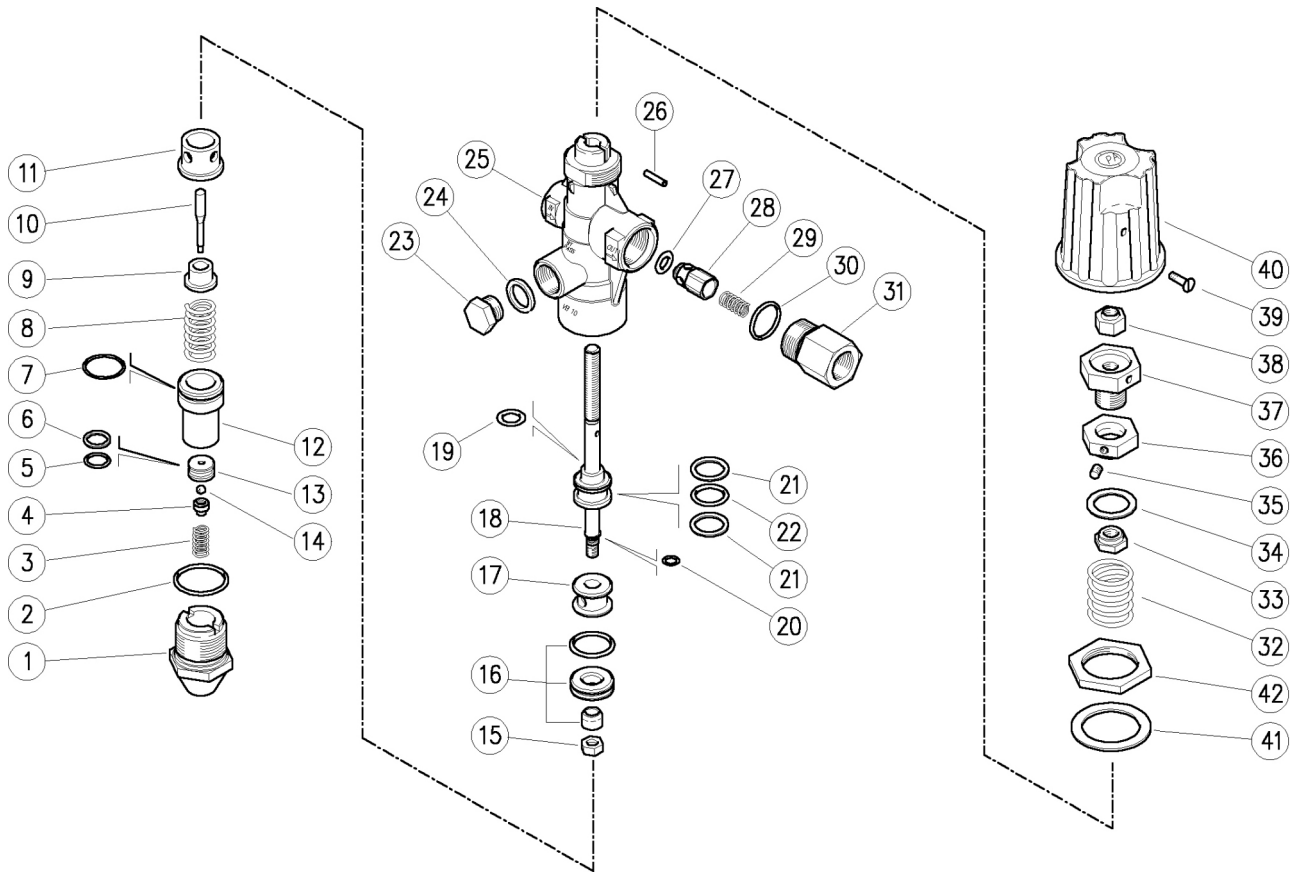

Pos.	P/N	Description	Q.ty	K1	K2	K3	K4	
1	60.1156.31R	Lower plug, M27x1,5 brass	1					3
2	10.3074.01R	O-ring, 1,78x25,12 mm Ni 85	1	•				10
3	60.8006.51R	Spring, 1x7,2x14 mm Sst.	1					3
4	60.8014.51R	Ball holding piston, Sst.	1					5
5	10.3058.02R	O-ring, 1,78x10,82 mm Ni 85	1	•				10
6	10.4090.00R	Back-up ring, 11,2x14x1,5 mm	1	•				10
7	10.3072.01R	O-ring, 1,78x20,35 mm Ni 85	1	•				10
8	60.1102.51R	Spring, 2,5x12,6x26 mm Sst.	1					10
9	60.1154.31R	Spacer ring, 5,2x15x8,5 mm brass	1					5
10	60.1157.51R	Pin, Sst.	1					5
11	60.1155.31R	Spacer ring, 11,5x24x19 mm brass	1					5
12	60.1153.31R	Seat holder, 24 mm brass	1					5
13	60.8015.51R	Seat, 3x14x7,5 mm Sst.	1	•				5
14	14.7404.00R	Ball, 3,5 mm Sst.	1	•				10
15	11.4540.00R	Hex. nut, M6, Sst.	1					10
16	60.1116.24	Seat, 10mm+O-ring, 1,78mm+shutt.	1	•				1
17	60.1105.31R	Spacer ring, 8,5x20,8x14,5mm brs.	1					3
18	60.1151.23R	Piston -VB10/2	1					3
19	10.3170.08R	O-ring, 2,62x7,6 mm Ni 85	1	•				10
20	10.3001.01R	O-ring, 1x4 mm Ni 85	1	•				10
21	10.4056.00R	Back-up ring, opn. 15,5x19,9x2 mm	2	•				10
22	10.3180.00R	O-ring, 2,62x15,08 mm	1	•				10
23	60.0028.31R	Plug,brass 3/8 Bsp,hex.19	1					25
24	14.4042.00R	Washer, 16,7x22x1,5 mm alu.	1					25
25	60.1108.35R	Housing -VB10, 3/8 FFF Bsp brass	1					3
26	15.1021.00R	Roll pin, 3x14 mm Sst.	1					10
27	10.3213.00R	O-ring, 3x6 mm	1	•				10
28	60.0052.99R	Shutter pin, brass+o-ring 3x6 mm	1					10
29	60.0053.51R	Spring, 0,7x9x20 mm Sst.	1					10
30	10.3070.02R	O-ring, 1,78x18,77 mm Ni 85	1	•				10
31	60.0058.31R	Delivery coupl., 3/8F Bsp brass	1					5
32	60.2203.61R	Spring, 4,2x27,4x31 mm z.pl.	1					10
33	60.2207.31R	Ring nut, M8 brass	1					10
34	60.2208.84R	Washer, 19x26x1,5 mm PA black	1					10
35	16.2105.00R	Set screw, DIN913 M5x6 mm	1					10
36	60.2252.31R	Ring nut, M16x1 brass	1					10
37	60.2253.31R	Regulating pin, brass	1					10
38	11.4589.10R	Hex. locknut, M8	1					10
39	16.1838.00R	Screw, DIN7985 M4x10 mm z.pl.	1					10
40	60.2251.84R	Valve regulating knob, PA black	1					5
41	14.3582.00R	Washer, 30,5x42x2 mm	1					10
42	60.2254.31R	Ring nut, M30 brass	1					10
Kit	P/N	Description						
K1	60.1158.24	Spares kit -VB10/2, 14x1pcs.	1					