

P.A. – S.p.A. – EQUIPAGGIAMENTI TECNICI DEL LAVAGGIO

VIA MILANO, 13 – CASELLA POSTALE 115 – 42048 RUBIERA (REGGIO EMILIA) – ITALY
 Tel. +39 0522 623611 – Fax. +39 0522 629600 – R.E.A. RE 156319 – R.I. RE11535 – Mecc. RE 013446
 C.F. e P. IVA 01035950359 – Cap. Soc. i.v. € 750.000,00 – Codice Identificativo C.E.E. IT 01035950359
 ART. 2497 – BIS C.C. DIREZIONE E COORDINAMENTO BENETTI srl R.I. TRIB. DI RE 01480690351
 Web: <http://www.pa-etl.it> – E-mail: info@pa-etl.it



VB 200/150-70 - Unloader Valve (discharging)

Technical manual: E 217

Pressure regulating unloader valve

At gun shut off, the water flow is bypassed at reduced pressure.

DN 25

- **60.5000.00** VB 200/150 1" NPT FF
- **60.5000.10** VB 200/150 OR VITON G 1" FF
- **60.5000.15** VB 200/150 G 1" FF
- **60.5020.00** VB 200/150 w/handwheel 1" NPT FF
- **60.5020.15** VB 200/150 w/handwheel G 1" FF
- **60.5025.00** VB 200/70 1" NPT FF
- **60.5025.15** VB 200/70 G 1" FF

- Sturdy steel and brass construction
- Hexagonal shaped check valve to avoid jamming.
- Max pressure adjustment by screw and locknut
- Model with manual set up simplified by a handwheel

Technical specifications

Max. flow rate: 200 l/min. Max temperature: 90°C (1)

Part Number	Rated pressure	Permissible pressure	Minimum adjustable pressure	(2) Trapped pressure at circuit closure	(3) Pressure drop to reset bypass	Inlet Outlet Bypass	Weight
	bar - MPa						
60.5000.00	150 - 15	170 - 17	15 - 1.5	15%	30%	1" NPT F	2025
60.5000.10	150 - 15	170 - 17	15 - 1.5	15%	30%	G 1" F	2025
60.5000.15	150 - 15	170 - 17	15 - 1.5	15%	30%	G 1" F	2025
60.5020.00	150 - 15	170 - 17	15 - 1.5	15%	30%	1" NPT F	2060
60.5020.15	150 - 15	170 - 17	15 - 1.5	15%	30%	G 1" F	2060
60.5025.00	70 - 7	80 - 8	7 - 0.7	15%	30%	1" NPT F	2000
60.5025.15	70 - 7	80 - 8	7 - 0.7	15%	30%	G 1" F	2000

(1) The valve has been designed for a continuous use at a water temperature of 60°C. It can resist for short periods at a maximum temperature of 90°C.

(2) This is the maximum pressure increase implemented in the circuit for the intervention of the valve and to bring all the fluid in bypass (percentage figures of the pressure set up)

(3) This is the pressure reduction necessary in comparison to the set up, in order that the valve brings back pressure in the circuit. (percentage figures of the pressure set up)

Instruction manual, maintenance, installation, spare parts. For a correct utilization, follow the directions of this manual Re-print them on the Use and Maintenance booklet of the machine.	n. 12.9217.00
--	---------------

DIMENSIONAL DRAWING

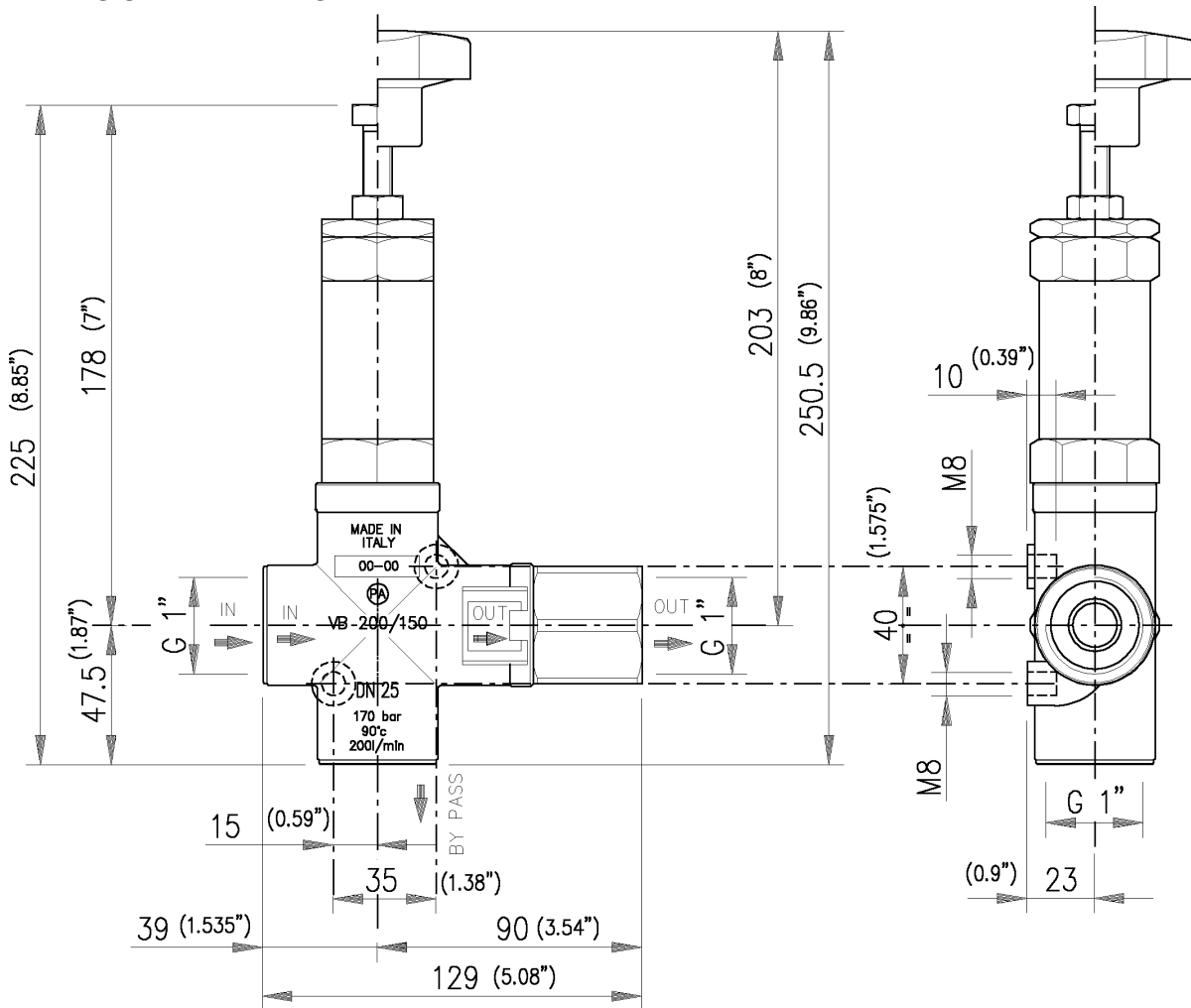

INSTRUCTIONS

SELECTION

This product is to be utilized with clean fresh water, even slightly additivated with normal detergents. For use involving different or corrosive liquids, contact the PA Technical department. Appropriate filtration should be installed when using unclean liquids. Choose the valve in line with the data of nominal running (system rated pressure, max flow and max temperature). In any case, the pressure of the machine should not exceed the permissible pressure rate imprinted on the valve.

INSTALLATION

This accessory, on a system that produces hot water, must be fitted in **front of the heat generator**. This product is bound to be incorporated on a finished machine. On a system that generates hot water, anticipate the fitting of accessories that limit the accidental increase of fluid temperature.

Always install a safety valve that protects the pressurized inlet channel.

Choose a correct nozzle size, which allows a regular discharge on bypass, at least 5% of the total flow of the system in order to achieve a constant pressure value and avoid troublesome pressure spikes at closure. If the nozzle wears out, the pressure drops.

On installation of a new nozzle, re-adjust the system to the original pressure setting.

OPERATIONS

The valve regulates the max pressure of the system through a piston, which acts on a ball correctly positioned, that closes the bypass opening. A check valve cuts out the delivery section, the pressure of which controls the drive of the piston.

Each regulation should be made when the system is operational and the nozzle open.

ATTENTION: The nut (pos 16) must never be removed otherwise a mechanical safety feature that limits the max pressure will lack, avoiding serious damage to persons and machine.

DISCHARGE SYSTEM AND WATER ADDUCTION

The bypass line should be returned into a tank with deflectors. By using a direct pump recycle, with elevated pressure intake, it is necessary to install a pressure reducer in order to have an even flow supply and to protect the circuit intake.

When the system is opened and closed frequently, it is recommended to install a thermal protector valve (VT3 or VT6) in order to eliminate excessive temperature build-up.

PROBLEMS AND SOLUTIONS

PROBLEMS	PROBABLE CAUSES	SOLUTIONS
Frequent unloader recycles	Damaged check valve O ring Leaking connections Restricted bypass	Replace Check and renew Clean or adapt
Unloader does not reach pressure	Unloader not properly sized Piston O rings worn out Material matter between seat and shutter Worn out nozzle	Change spring or type of valve Replace Clean the seat Replace
Pressure peaks	There is not a min of 5% of total flow in bypass Excessive flow in bypass Spring totally compressed	Reset Change type of valve or adjust passages Loosen knob and change nozzle
Unloader does not bypass at low pressure	Jammed check valve Check valve O ring worn out Material matter on check valve	Clean or replace Replace Clean

REGULATIONS : see norm manual

For a correct utilization, follow the directions described in this manual and re-print them on the Use and maintenance manual of the machine.

Make sure that you are given **the Original Conformity Declaration** for the accessory chosen. The present manual is valid for all unloader valves named **VB 200/150-70**.

MAINTENANCE

Maintenance has to be carried out by **Specialized Technicians**.

STANDARD: every 400 working hours (circa 10,000 cycles), check and lubricate the seals with water resistant grease.

SPECIAL: every 800 working hours (circa 20,000 cycles), control the wear of the seals and internal parts and if necessary, replace with original PA parts taking care during installation and to lubricate with water resistant grease.

ATTENTION: reassemble the valve in the correct manner paying special attention to the Nut (pos 16) by fastening it with a drop of strong glue.

The manufacturer is not to be considered responsible for damage as a result from incorrect fitting and maintenance

Technical data, descriptions and illustrations are indicative and liable to modification without notice.

60.5000.00 VB200/150 unload. 1" F Npt
 60.5000.10 VB200/150 unload. 1" F Bsp Viton O-Rings
 60.5000.15 VB200/150 unload. 1" F Bsp
 60.5020.00 VB200/150 unload. 1" F Npt +handwheel

60.5020.15 VB200/150 unloader 1" F Bsp +hand wheel
 60.5025.00 VB200/70 unldr valve, 1" Npt
 60.5025.15 VB200/70 unldr valve, 1" Bsp FF

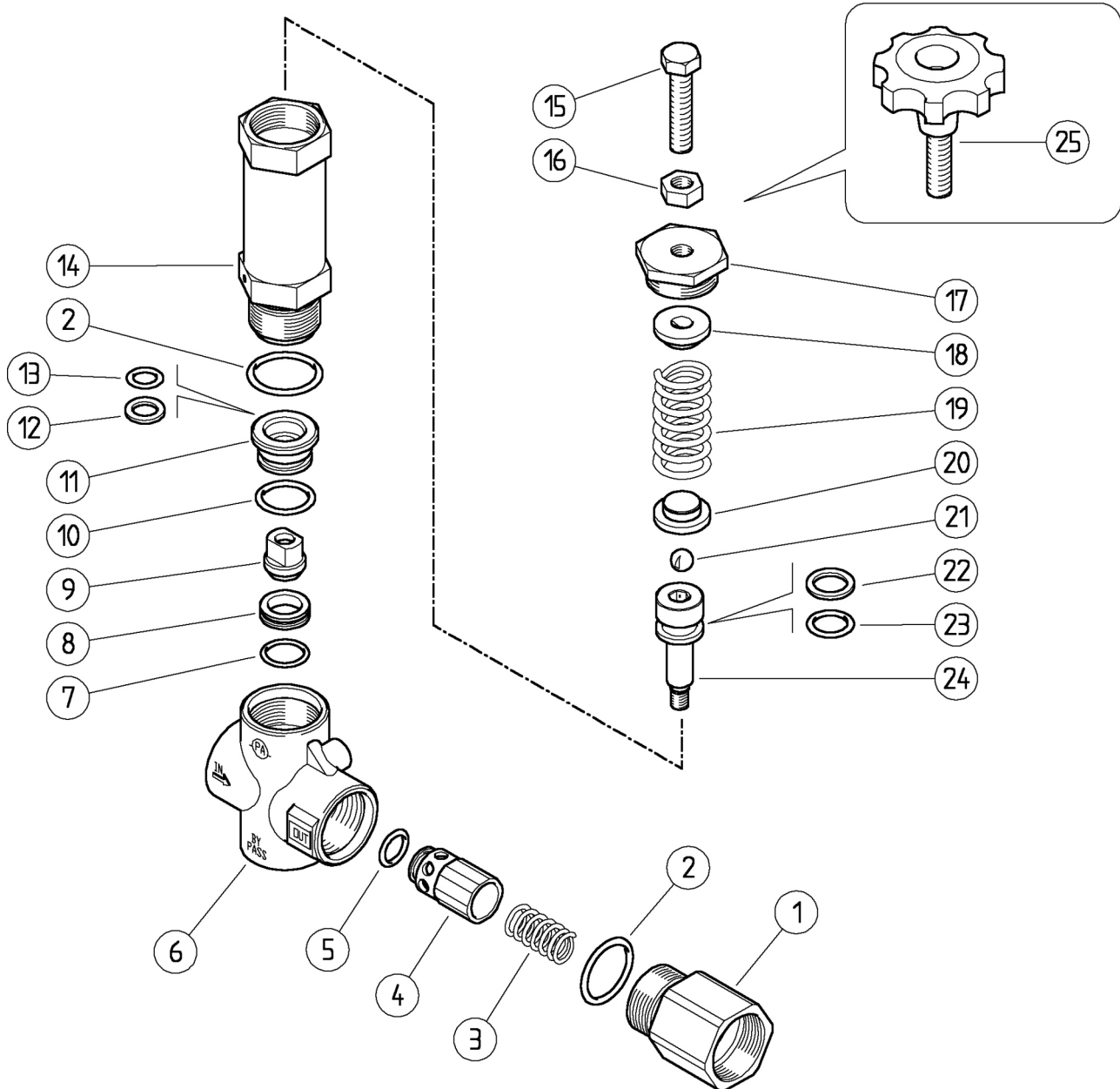

Pos.	P/N	Description	Q.ty	K1	K2	K3	K4
1	60.5014.31R	Shutter coupl., 1"Npt F brass	1				3
1	60.5026.31R	Coupling, 1"Bsp F brass (1,2)	1				3
2	10.3206.01R	O-ring, 2,62x28,25 mm	2	•	•		10
3	60.5013.51R	Spring, 1,3x18x29 mm Sst.	1				10
4	60.5012.99R	Shutter pin, brass+or 5,33x12,06 mm N	1				5
5	10.3314.00R	O-ring, 5,33x12,06 mm	1	•			10
5	10.3314.10R	O-ring, 5,33x12,06 mm Vi 90 (3)	1	•			10
6	60.5001.35R	Housing-VB200/60-150, 1"Npt brass	1				1
6	60.5024.35R	Hous.-VB200/150-1"Bsp FF (1,2)	1				1
7	10.3072.01R	O-ring, 1,78x20,35 mm Ni 85	1	•	•		10
8	60.5002.51R	Seat, 15,8x23x6 mm Sst.	1	•	•		5
9	60.5003.51R	Shutter pin, M8 Sst.	1	•	•		3
10	10.3195.01R	O-ring, 2,62x20,29 mm Ni 90	1	•	•		10
11	60.5010.31R	Reduction bushing, brass	1				10
12	10.4080.00R	Back-up ring, 12x18,2x2 mm	1	•	•		10
13	10.3234.00R	O-ring, 3,53x10,69 mm	1	•			10

Pos.	P/N	Description	Q.ty	K1	K2	K3	K4
13	10.3234.10R	O-ring, 3,53x10,69 mm Vi 70 (3)	1		•		10
14	60.5009.31R	Piston holder, brass	1				3
15	60.5011.61R	Valve regulating screw, M10x44 z.pl. (4)	1				10
16	11.4629.00R	Hex. nut, M10	1				10
17	60.5008.31R	Upper plug, M10 brass	1				10
18	60.5005.31R	Spring guide spacer, brass	1				10
19	60.5006.61R	Spring, 6x30x62 mm	1				5
19	60.5031.61R	Spring 5x23x62 mm (5,2)	1				1
20	60.5007.31R	Spring guide spacer, brass	1				10
21	14.7461.00R	Ball, 13/32" Sst.	1				10
22	10.4081.00R	Back-up ring, 15,8x22x2 mm	1	•	•		10
23	10.3237.00R	O-ring, 3,53x15,47 mm	1	•			10
23	10.3237.10R	O-ring, 3,53x15,47 mm Vi 70 (3)	1		•		10
24	60.5004.51R	Piston, M8 Sst.	1				5
25	60.5021.22	Handwheel, 70mm -M10x44 (6,7)	1				2

Kit	P/N	Description	
K1	60.5016.24	Spares kit -VB200/150, 10x1pcs.	1
K2	60.5019.24	Spares kit -VB200/150, or. vit.10x1pcs.	1

(1) 60.5000.15 (2) 60.5025.15 (3) 60.5000.10 (4) 60.5000.00 (5) 60.5025.00 (6) 60.5020.00 (7) 60.5020.15