

P.A. – S.p.A. – EQUIPAGGIAMENTI TECNICI DEL LAVAGGIO

VIA MILANO, 13 – CASELLA POSTALE 115 – 42048 RUBIERA (REGGIO EMILIA) – ITALY
 Tel. +39 0522 623611 – Fax. +39 0522 629600 – R.E.A. RE 156319 – R.I. RE11535 – Mecc. RE 013446
 C.F. e P. IVA 01035950359 – Cap. Soc. i.v. € 750.000,00 – Codice Identificativo C.E.E. IT 01035950359
 ART. 2497 – BIS C.C. DIREZIONE E COORDINAMENTO BENETTI srl R.I. TRIB. DI RE 01480690351
 Web: <http://www.pa-etl.it> – E-mail: info@pa-etl.it



VB 80 150/280/400 Sst Aisi 303

Technical manual: E 214

Pressure regulating valve equipped with double connection for inlet port.
 Possibility of different pressure settings by a choice of 3 spring models.
 At gun shut off, the water flow is bypassed at reduced pressure.

DN 15

- **60.0430.15** G1/2 F white spring
- **60.0430.40** G1/2 F blue spring
- **60.0430.00** G1/2 F black spring
- **60.0430.17** 1/2 Npt F white spring
- **60.0430.45** 1/2 Npt F blue spring
- **60.0430.50** 1/2 Npt F black spring

- Sturdy construction in Sst Aisi 303
- Return action of the piston by means of a powerful spring, for confident working and a reliable pressure adjustment.
- Multiple connections for easy installation
- Hexagonal shaped check valve to avoid jamming.

Technical specifications

Max. flow rate: 80 l/min.(1) Max temperature: 90°C (2)

Part Number	Rated pressure	Permissible pressure	Minimum adjustable pressure	(3)Trapped pressure at circuit closure	(4)Pressure drop to reset bypass	Inlet Outlet Bypass	Weight g
	bar - MPa	bar - MPa	bar - MPa	%	%		
60.0430.15	150 - 15	170 - 17	15 – 1.5	9 %	24%	G1/2 F	1240
60.0430.40	280 - 28	310 - 31	28 – 2.8	8 %	25%	G1/2 F	1275
60.0430.00	400 - 40	450 - 45	40 - 4	10%	25%	G1/2 F	1330
60.0430.17	150 - 15	170 - 17	15 – 1.5	9 %	24%	1/2Npt F	1240
60.0430.45	280 - 28	310 - 31	28 – 2.8	8 %	25%	1/2Npt F	1275
60.0430.50	400 - 40	450 - 45	40 - 4	10%	25%	1/2Npt F	1330

(1) Max.flow rate: 30 l/min if fed by lower fitting.

(2) The valve has been designed for a continuous use at a water temperature of 60°C. It can resist for short periods at a maximum temperature of 90°C.

(3) This is the maximum pressure increase implemented in the circuit for the intervention of the valve and to bring all the fluid in bypass (percentage figures of the pressure set up)

(4) This is the pressure reduction necessary in comparison to the set up, in order that the valve brings back pressure in the circuit. (percentage figures of the pressure set up)

Instruction manual, maintenance, installation, spare parts.

For a correct utilization, follow the directions of this manual

Re-print them on the Use and Maintenance booklet of the machine.

n. 12.9214.00

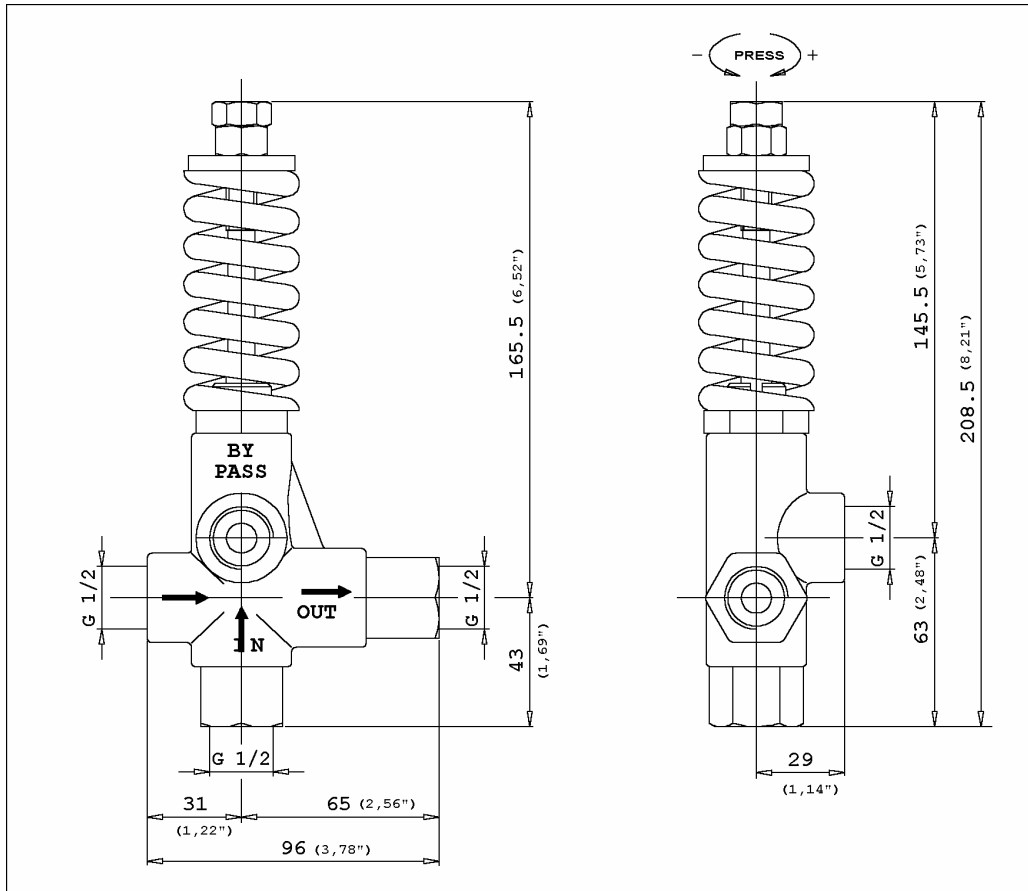
DIMENSIONAL DRAWING**INSTRUCTIONS****SELECTION**

This product is to be utilized with clean fresh water, even slightly additivated with normal detergents. For use involving different or corrosive liquids, contact the PA Technical department. Appropriate filtration should be installed when using unclean liquids. Choose the valve in line with the data of nominal running (system rated pressure, max flow and max temperature). **In any case, the pressure of the machine should not exceed the permissible pressure rate imprinted on the valve.** The feeding from the lower fitting is possible with a reduced flow rate (see point 1)

INSTALLATION

This accessory, on a system that produces hot water, **must be fitted upstream the heat generator.** This product is bound to be incorporated on a finished machine. On a system that generates hot water, anticipate the fitting of accessories that limit the accidental increase of fluid temperature.

Always install a safety valve that protects the pressurized inlet channel.

Choose a correct nozzle size, which allows a regular discharge on bypass, at least 5% of the total flow of the system in order to achieve a constant pressure value and avoid troublesome pressure spikes at closure. If the nozzle wears out, the pressure drops. On installation of a new nozzle, re-adjust the system to the original pressure setting. The use of the white spring (150 bar – 15 MPa), is advisable in presence of low pressure, to decrease during lance aperture, motor strain caused by overpressure necessary to obtain bypass condition.

OPERATIONS

The valve regulates the max pressure of the system through a piston, which acts on a ball correctly positioned, that closes the bypass opening. A check valve cuts out the delivery section, the pressure of which controls the drive of the piston. Each regulation should be made when the system is operational and the nozzle open.

After adjusting the valve to the set pressure, tighten the nut (pos.7*) and mark it with a drop of paint in order to emphasize any possible tampering.

ATTENTION: The nut (pos 7* nr 1pz) must never be removed otherwise a mechanical safety feature that limits the max pressure will lack, avoiding serious damage to persons and machine..

DISCHARGE SYSTEM AND WATER ADDUCTION

The bypass line should be returned into a tank with deflectors. By using a direct pump recycle, with elevated pressure intake, it is necessary to install a pressure reducer in order to have an even flow supply and to protect the circuit intake.

When the system is opened and closed frequently, it is recommended to install a thermal protector valve (VT3 or VT6) in order to eliminate excessive temperature build-up.

For the pump return line, it is advisable to fit a hose at least 250mm in length.

PROBLEMS AND SOLUTIONS

PROBLEMS	PROBABLE CAUSES	SOLUTIONS
Frequent unloader recycles	Damaged check valve O ring Leaking connections Restricted bypass	Replace Check and renew Clean or adapt
Unloader does not reach pressure	Unloader not properly sized Piston O rings worn out Material matter between seat and shutter Worn out nozzle	Change spring or type of valve Replace Clean the seat Replace
Pressure peaks	There is not a min of 5% of total flow in bypass Excessive flow in bypass Spring totally compressed	Reset Change type of valve or adjust passages Loosen knob and change nozzle
Unloader does not bypass at low pressure	Jammed check valve Check valve O ring worn out Material matter on check valve	Clean or replace Replace Clean

REGULATIONS : *see norm manual*

The accessory hereby described bears the CE marking in accordance with the Norms and Directives applied on the Declaration of conformity.

For a correct utilization, follow the directions described in this manual and re-print them on the Use and maintenance manual of the machine.

Make sure that you are given **the Original Conformity Declaration** for the accessory chosen. The present manual is valid for all unloader valves named **VB 80 150/280/400 Aisi303**.

MAINTENANCE

Maintenance has to be carried out by **Specialized Technicians**.

STANDARD: every 400 working hours (circa 10,000 cycles), check and lubricate the seals with water resistant grease.

SPECIAL: every 800 working hours(circa 20,000 cycles), control the wear of the seals and internal parts and if necessary, replace with original PA parts taking care during installation and to lubricate with water resistant grease.

ATTENTION: reassemble the valve in the correct manner paying special attention to the Nut (pos 7*) by fastening it with a drop of strong glue.

The manufacturer is not to be considered responsible for damage as a result from incorrect fitting and maintenance

Technical data, descriptions and illustrations are indicative and liable to modification without notice.

60.0430.00 VB80/400 unload. 1/2F Bsp Ai303
 60.0430.15 VB80/150 unload. 1/2F Bsp Ai303
 60.0430.40 VB80/280 unload. 1/2F Bsp Ai303
 60.0430.50 VB80/400 unload. 1/2F Npt Ai303
 60.0448.15 VB80A/150 unl. 1/2Bsp Aisi 303 white sp.-

60.0448.28 VB80A/280 unl. 1/2Bsp Aisi 303 blue spring -
 60.0455.15 VB80/150 unload. 1/2F Bsp Ai303 +vit.O-R
 60.0455.60 VB80/280 unload. 1/2F Bsp Ai303 +vit.O-R
 60.0455.80 VB80/400 unload. 1/2F Bsp Ai303 +vit.O-R

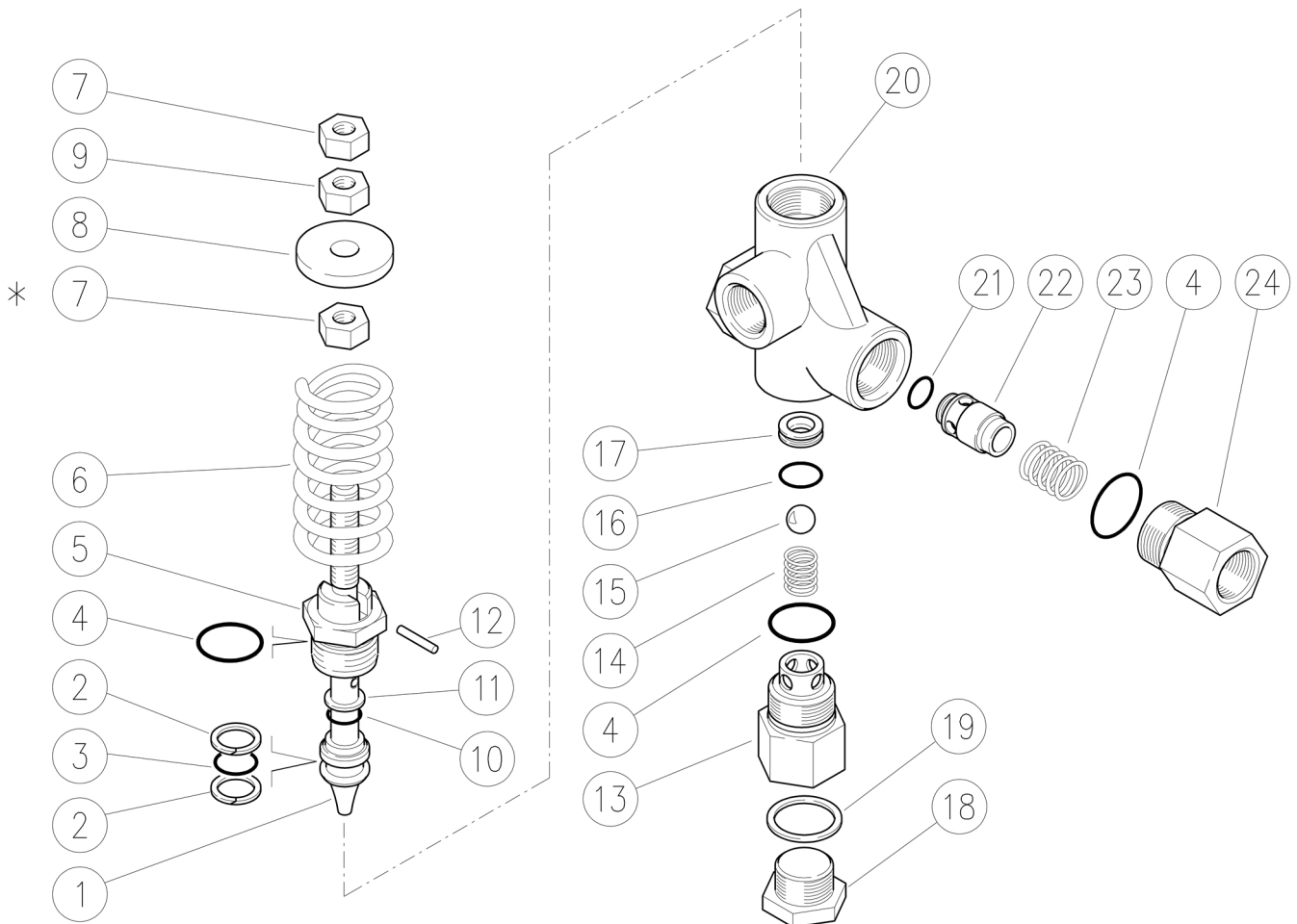

Pos.	P/N	Description	Q.ty	K1	K2	K3	K4
1	60.0432.51R	Piston, M10 Sst. (1,2,3)	1				3
1	60.0407.51R	Piston, M10 Sst.	1				5
2	10.4014.00R	Back-up ring, opn. 18x13,5x1,2 mm	2	•	•		10
3	10.3178.01R	O-ring, 2,62x13,1 mm Ni 85	1	•	•		10
3	10.3178.10R	O-ring, 2,62x13,1 mm Vi 70 (4,5,3)	1		•	•	10
4	10.3072.01R	O-ring, 1,78x20,35 mm Ni 85	3	•	•		10
4	10.3072.10R	O-ring, 1,78x20,35 mm Vi 70 (4,5,3)	3		•	•	10
5	60.0433.51R	Stem holder, Sst.	1				5
6	60.0434.61R	Spring, 8,5x38x80 mm black (1,2,3)	1				3
6	60.0412.61R	Spring, 7,5x35x70 mm blue (6,7,5)	1				10
6	60.0411.61R	Spring, 6,5x33x70 mm white (8,9,4)	1				3
7	11.4629.00R	Hex. nut, M10 (1,2)	2				10
7	11.4627.50R	Hex. nut, M10, Sst. (8,6,9,7)	3				10
8	60.0406.31R	Spring holding washer, brass	1				10
9	11.4630.00R	Hex. nut, M10 (1,2)	1				10
10	10.3174.01R	O-ring, 2,62x9,93 mm Ni 85	1	•	•		10
10	10.3174.10R	O-ring, 2,62x9,93 mm Vi 70 (4,5,3)	1		•	•	10
11	10.4015.00R	Back-up ring, 10x14,5x1,2 mm	1	•	•		10
12	15.1032.00R	Roll pin, 3x18 mm Sst.	1				10

Pos.	P/N	Description	Q.ty	K1	K2	K3	K4
13	60.0405.51R	Suction coupl., 1/2F Bsp Sst.	1				3
13	60.0438.51R	Suction coupl., 1/2"Npt Sst. (2)	1				3
14	60.0410.51R	Spring, 1,6x11,5x20 mm Sst.	1				5
15	14.7461.00R	Ball, 13/32" Sst.	1	•	•	•	10
16	10.3060.01R	O-ring, 1,78x12,42 mm Ni 85	1	•	•		10
16	10.3060.10R	O-ring, 1,78x12,42 mm Vi 70 (4,5,3)	1		•	•	10
17	60.0408.51R	Seat, 8,5x15,9x4,5 mm Sst.	1	•	•	•	5
18	60.0413.51R	Plug, sst. 1/2 Bsp, hex.27	1				3
18	60.0444.51R	Grub screw, sst. 1/2 Npt (2)	1				1
19	14.4101.00R	Sealing washer, 1/2 Bsp	1				10
20	60.0431.55R	Housing -VB80, 1/2F Bsp Sst.	1				3
20	60.0436.55R	Housing -VB80, 1/2F Npt Sst. (2)	1				1
21	10.3292.00R	O-ring, 4x8 mm	1	•	•		10
21	10.3292.10R	O-ring, 4x8 mm Vi 70 (4,5,3)	1		•	•	10
22	60.9403.95R	Shutter pin, Sst.+or 4x8 mm N	1				5
22	60.9403.92R	Shutter pin, Sst.+or 4x8 mm V (4,5,3)	1				5
23	60.0409.51R	Spring, 0,8x15,4x13 mm Sst.	1				5
24	60.0402.51R	Shutter coupl., 1/2F Bsp Sst.	1				3
24	60.0437.51R	Delivery coupl., 1/2"Npt Sst. (2)	1				5

Kit	P/N	Description	Q.ty
K1	60.0451.24	Spares kit -VB80/400, Sst. 9x1pcs.	1
K2	60.0435.24	Spares kit -VB80/400, Sst. 9x5pcs.	1
K3	60.0446.24	Seals kit -VB80+O-ring, FKM 7x1pcs.	1
K4	60.0452.24	Kit sp. parts -VB80 Viton, 9x5 pcs	1

(1) 60.0430.00 (2) 60.0430.50 (3) 60.0455.80 (4) 60.0455.15 (5) 60.0455.60 (6) 60.0430.40 (7) 60.0448.28 (8) 60.0430.15 (9) 60.0448.15