

**P.A. – S.p.A. – EQUIPAGGIAMENTI TECNICI DEL LAVAGGIO**

VIA MILANO, 13 – CASELLA POSTALE 115 – 42048 RUBIERA (REGGIO EMILIA) – ITALY  
 Tel. +39 0522 623611 – Fax. +39 0522 629600 – R.E.A. RE 156319 – R.I. RE11535 – Mecc. RE 013446  
 C.F. e P. IVA 01035950359 – Cap. Soc. i.v. € 750.000,00 – Codice Identificativo C.E.E. IT 01035950359  
 ART. 2497 – BIS C.C. DIREZIONE E COORDINAMENTO BENETTI srl R.I. TRIB. DI RE 01480690351  
 Web: <http://www.pa-etl.it> – E-mail: [info@pa-etl.it](mailto:info@pa-etl.it)



## VS310 - COMPENSATED RELIEF VALVE

**Technical manual: E 279**

Compensated pressure regulating valve.  
 Regulates the bypass of the fluid with a minimum variation of the pressure.  
 Suitable to be utilized as a relief valve.

**DN 10**

- **60.0500.00 VS310** G3/8 F

- Central body in brass.
- Internal components in Sst.
- Moving parts totally protected.

**AS A RELIEF VALVE**

- Secure intervention discharging all the flow.
- Prompt and effective damping against pressure spikes.

**TECHNICAL SPECIFICATIONS**

PART N.	RATED PRESSURE		PERMISSIBLE PRESSURE		MINIMUM ADJUSTABLE PRESSURE		RATED TEMPERATURE (1)	MAXIMUM FLOW RATE	WEI GHT	INLET OUTLET	BY-PASS
	bar	MPa	bar	MPa	bar	MPa	°C	l/min	g		
60.0500.00	310	31	350	35	35	3.5	90	40	380	G 3/8" F	G 3/8" F

**(1)** The valve has been designed for a continuous use at a water temperature of 60°C. It can resist for short periods at a maximum temperature of 90°C.

**Instruction manual, maintenance, installation, spare parts.**

For a correct utilization, follow the directions of this manual

**Re-print them on the use and maintenance booklet of the machine.**

n. 12.9279.50

## DIMENSIONAL DRAWING

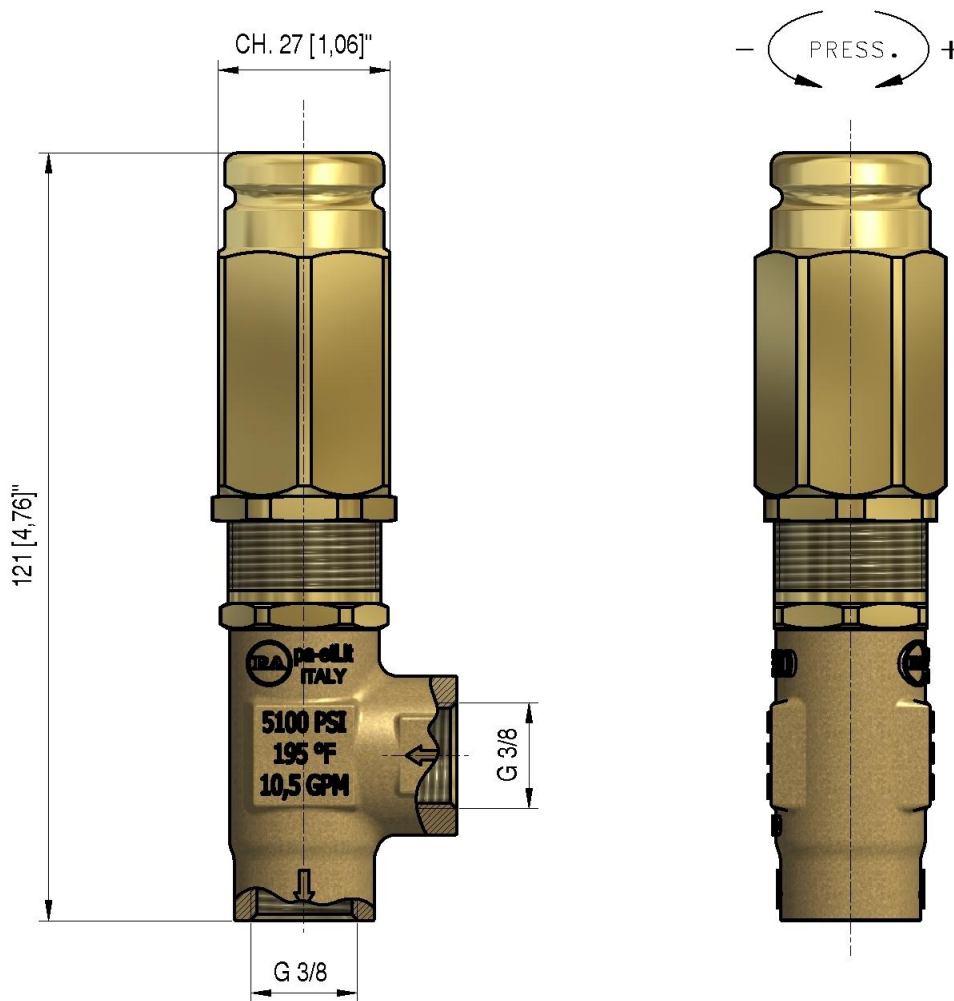

## INSTRUCTIONS

### SELECTION

This product is to be utilized with clean fresh water, even slightly additivated with normal detergents. For use involving different or corrosive liquids, contact the PA Technical department. Choose the valve in line with the data of nominal running (system rated pressure, max flow and max temperature). In any case, the pressure of the machine should not exceed the permissible pressure rate imprinted on the valve. When in use as pressure regulator, adopt a nozzle that allows a bypass of at least 5% of the total flow, bearing in mind that a worn out nozzle causes pressure loss. The valve, assembled in line with these indications, avoids pressure spikes whilst the machine is in operation.

### INSTALLATION

This accessory, on a system that produces hot water, must be fitted **upstream of the heat generator**.

As a **RELIEF VALVE**: in the case when frequently combined with unloader valves, it has to be fitted in the section that remains pressurized when the gun is shut off.

As a **PRESSURE REGULATOR**: maintains the pressure in the system steady during flow changes. **Always** install in combination with a suitable Relief valve. In case of discharge in the tank or directly into the pump, it is necessary to provide devices capable to prevent damaging turbulence to the liquid flow.

### OPERATIONS

The valve inlet is on the side, the discharge is opposite the adjustment knob (pos.1).The discharge should be returned to a baffled tank. If, on the contrary, the pump is fed directly from the water mains, it is advisable to install a pressure reducing valve, before the pump, to avoid dangerous pressure spikes which could badly damage manifolds and suction valves. In case of extended conditions of bypass directed to the suction side of the pump, it is recommended to install a thermal valve (VT3 or VT6) to avoid dangerous water temperature build-up.

**PRESSURE ADJUSTMENT/SETTING**

As a RELIEF VALVE: the adjustment has to be made in such a way that the pressure setting is not superior to the system working pressure and its accessories; this prevents the arising of numerous pressure increases in hot water systems and static pressure (gun shut off).

As a PRESSURE REGULATOR: adjust the valve when the system is pressurized and the gun open. The operation will be easy and smooth if the proper nozzle is chosen. When rotating the adjustment knob, it has to correspond to a consequent pressure increase; should the pressure stop increasing before reaching the desired value, **do not insist**, but check the correct nozzle size in relation to flow and pressure. On reaching the desired pressure, tighten the nut (pos.5) against the knob (pos.1) touching them with a drop of paint in order to emphasize any tampering or slackness.

**PROBLEMS AND SOLUTIONS**

PROBLEMS	PROBABLE CAUSES	SOLUTIONS
Valve cycles	<ul style="list-style-type: none"> <li>- Air inside the system</li> <li>- Worn out seals</li> <li>- Clogged circuit</li> </ul>	<ul style="list-style-type: none"> <li>- Flush out</li> <li>- Replace</li> <li>- Clean or widen passages</li> </ul>
The valve does not reach pressure	<ul style="list-style-type: none"> <li>- Unproper nozzle size</li> <li>- Seat/shutter/ball worn out</li> <li>- Damaged nozzle</li> <li>- Impurities</li> </ul>	<ul style="list-style-type: none"> <li>- Modify</li> <li>- Replace</li> <li>- Replace</li> <li>- Clean</li> </ul>
Pressure drop	<ul style="list-style-type: none"> <li>- Worn out nozzle</li> <li>- Pump gaskets worn out</li> <li>- Valve seat worn out</li> <li>- Air inside the system</li> </ul>	<ul style="list-style-type: none"> <li>- Replace</li> <li>- Replace</li> <li>- Replace</li> <li>- Flush out</li> </ul>
Pressure spikes	<ul style="list-style-type: none"> <li>- There is not a min.5% of total flow in by-pass</li> <li>- Clogged nozzle</li> </ul>	<ul style="list-style-type: none"> <li>- Re-adjust</li> <li>- Clean</li> <li>- Repeat adjustment and replace nozzle</li> </ul>
Water leakage from bypass Valve pounding	<ul style="list-style-type: none"> <li>- O-ring seat damaged</li> <li>- Damaged seat</li> <li>- Impurities or worn out valve pumps</li> </ul>	<ul style="list-style-type: none"> <li>- Replace</li> <li>- Replace</li> <li>- Clean</li> <li>- Replace</li> </ul>

**MAINTENANCE**

In normal working conditions the relief valve should not open (no water discharge); if the valve is fitted on the pump head, it is in any case submitted to pressure cycles which have to be calculated for maintenance.

STANDARD: every 400 working hours (approximately 10000 working cycles of the system), check and lubricate the seals with water resistant grease.

SPECIAL: every 800 working hours (approximately 20000 working cycles of the system), control the wear of the seals and internal parts and, if necessary, replace with original PA parts taking care, during installation, to lubricate with water resistant grease.

Furthermore verify the absence of scale or dirt on the seat and the shutter.

**ATTENTION:** reassemble the valve in the correct manner paying special attention how to set the valve as described in the paragraph PRESSURE ADJUSTMENT/SETTING.

Maintenance has to be carried out by Specialized Technicians.

**The manufacturer is not to be considered responsible for damage as a result from incorrect fitting and maintenance**

Technical data, descriptions and illustrations are indicative and liable to modification without notice

**REGULATIONS : see norm manual**

For a correct utilization, follow the directions described in this manual and re-print them on the Use and maintenance manual of the machine.

Make sure that you are given **the Original Conformity Declaration** for the accessory chosen.

The present manual is valid for all unloader valves named **VS310**.

60.0500.00 VS 310 safety valv. 3/8F Bsp -1 inl.port

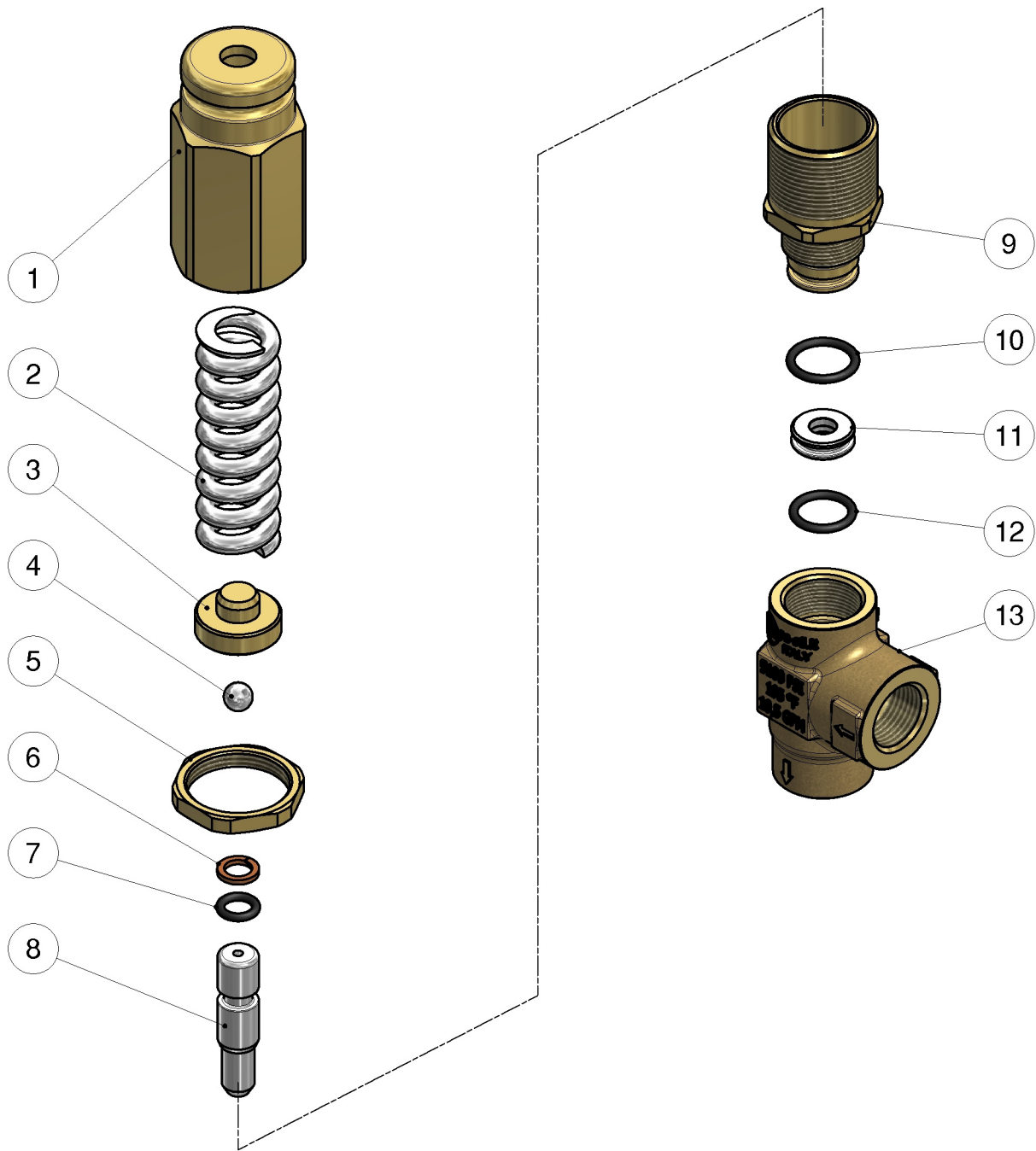

Pos.	P/N	Description	Q.ty	K1	K2	K3	K4	
1	60.0532.31R	Valve regulating knob, M24 brass	1					10
2	60.0584.61R	Spring, 4,2x18,4x56 mm z.pl.	1					5
3	60.0583.31R	Spring guide spacer, brass	1					5
4	14.7421.50R	Ball, 1/4" Sst.	1					10
5	60.0523.31R	Ring nut, M24x1,25 brass	1					10
6	10.4003.06R	Back-up ring, 6,2x9,2x1,2 mm	1	•				10
7	10.3051.01R	O-ring, 1,78x6,07 mm	1	•				10

Kit	P/N	Description	Q.ty
K1	60.0508.24	Spares kit -VS310, 5x1pcs.	1

Pos.	P/N	Description	Q.ty	K1	K2	K3	K4	
8	60.0510.51R	Vs310 sst. piston	1					2
9	60.0507.31R	Spring coupl.	1					2
10	10.3060.01R	O-ring, 1,78x12,42 mm Ni 85	1	•				10
11	30.5516.51R	Seat, 6,0x13,9 mm	1	•				10
12	10.3059.01R	O-ring, 1,78x11,11 mm Ni 85	1	•				10
13	60.0505.35R	Housing -VS310, 3/8F Bsp brass	1					2