

**P.A. – S.p.A. – EQUIPAGGIAMENTI TECNICI DEL LAVAGGIO**

VIA MILANO, 13 – CASELLA POSTALE 115 – 42048 RUBIERA (REGGIO EMILIA) – ITALY  
 Tel. +39 0522 623611 – Fax. +39 0522 629600 – R.E.A. RE 156319 – R.I. RE11535 – Mecc. RE 013446  
 C.F. e P. IVA 01035950359 – Cap. Soc. i.v. € 750.000,00 – Codice Identificativo C.E.E. IT 01035950359  
 ART. 2497 – BIS C.C. DIREZIONE E COORDINAMENTO BENETTI srl R.I. TRIB. DI RE 01480690351  
 Web: <http://www.pa-etl.it> – E-mail: [info@pa-etl.it](mailto:info@pa-etl.it)



## VS160 – VS30 – Compensated relief valve

**Technical manual: E 218**

Compensated pressure regulating valve.  
 Regulates the bypass of the fluid with a minimum variation of the pressure.  
 Suitable to be utilized as a relief valve.

**DN 8**

- **60.0560.00** VS160 G1/4 M
- **60.0560.30** VS30 G1/4 M

- Central body in brass
- Internal components in Sst.
- Moving parts totally protected.
- Discharge through integrated hose barb.
- Secure intervention discharging all the flow.

### TECHNICAL SPECIFICATIONS

Max. flow rate 14 l/min - Max. temperature 90°C (1)

Part number	Rated pressure	Permissible pressure	Minimum adjustable pressure	(2) Pressure increase as a VS	Inlet	Bypass	Weight
	bar - MPa	bar - MPa	bar - MPa	bar - MPa			
<b>60.0560.00</b>	140 - 14	160 - 16	14 - 1.4	20 - 2	G1/4 M	G1/8 F D. 13 mm	135
<b>60.0560.30</b>	30 - 3	35 - 3.5	5 - 0.5	15 - 1.5	G1/4 M	G1/8 F D. 13 mm	135

(1) The valve has been designed for a continuous use at a water temperature of 60°C. It can resist for short periods at a maximum temperature of 90°C.

(2) **Pressure increase** = is the increase of pressure needed into the valve for discharging the max. flow when utilized at rated pressure

**Instruction manual, maintenance, installation, spare parts.**

For a correct utilization, follow the directions of this manual

**Re-print them on the use and maintenance booklet of the machine.**

n. 12.9218.00

## DIMENSIONAL DRAWING

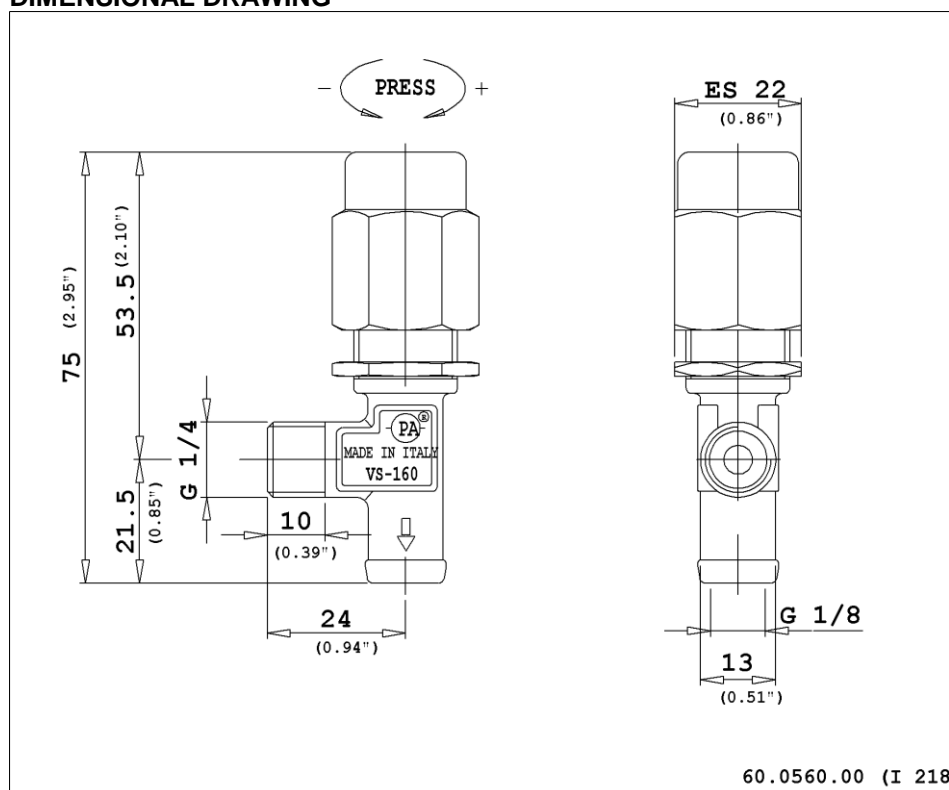

## INSTRUCTIONS

### SELECTION

This product is to be utilized with clean fresh water, even slightly additivated with normal detergents. For use involving different or corrosive liquids, contact the PA Technical department. Choose the valve in line with the data of nominal running (system rated pressure, max flow and max temperature). In any case, the pressure of the machine should not exceed the permissible pressure rate imprinted on the valve. When in use as pressure regulator, adopt a nozzle that allows a bypass of at least 5% of the total flow, bearing in mind that a worn out nozzle causes pressure loss. The valve, assembled in line with these indications, avoids pressure spikes whilst the machine is in operation.

### INSTALLATION

This accessory, on a system that produces hot water, must be fitted **in front of the heat generator**.

Utilize connection fittings in compliance to the dimensions and performance of the valve. Avoid restriction of the passage diameters which can be the cause of malfunctions, pressure reduction and duration.

As a **RELIEF VALVE**: in the case when frequently combined with unloader valves and low pressure in the pump, it has to be fitted in the section that remains pressurized when the gun is shut off.

### OPERATIONS

The valve inlet is on the side, the discharge is opposite the adjustment knob (pos.10). The discharge should be returned to a baffled tank. If, on the contrary, the pump is fed directly from the water mains, it is advisable to install a pressure reducing valve, before the pump, to avoid dangerous pressure spikes which could badly damage manifolds and suction valves. In case of extended conditions of bypass directed to the suction side of the pump, it is recommended to install a thermal valve (VT3 or VT6) to avoid dangerous water temperature build-up.

### PRESSURE ADJUSTMENT/SETTING

As a **RELIEF VALVE**: the adjustment has to be made in such a way that the pressure setting is not superior to the system working pressure and its accessories; this prevents the arisal of numerous pressure increases in hot water systems and static pressure (gun shut off). In order not to exceed the fixed pressure, it is advised to lock the nut (pos 2) against the knob (pos 10) touching them with paint to avoid loosening or tampering.

## PROBLEMS AND SOLUTIONS

PROBLEMS	PROBABLE CAUSES	SOLUTIONS
----------	-----------------	-----------

Valve cycles	- Air inside the system - Worn out seals - Clogged circuit	- Flush out - Replace - Clean or widen passages
The valve does not reach pressure	- Unproper nozzle size - Seat/shutter/ball worn out - Damaged nozzle	- Modify - Replace - Replace
Pressure drop	- Worn out nozzle - Pump gaskets worn out - Valve seat worn out - Air inside the system	- Replace - Replace - Replace - Flush out
Pressure spikes	- There is not a min.5% of total flow in bypass - Clogged nozzle	- Re-adjust - Clean - Repeat adjustment and replace nozzle
Water leakage from bypass	- O-ring seat damaged - Damaged seat	- Replace - Replace

#### MAINTENANCE

In normal working conditions the relief valve should not open (no water discharge); if the valve is fitted on the pump head, it is in any case submitted to pressure cycles which have to be calculated for maintenance.

STANDARD: every 400 working hours (approximately 10000 working cycles of the system), check and lubricate the seals with water resistant grease.

SPECIAL: every 800 working hours (approximately 20000 working cycles of the system), control the wear of the seals and internal parts and, if necessary, replace with original PA parts taking care, during installation, to lubricate with water resistant grease. Furthermore verify the absence of scale or dirt on the seat and the shutter.

**ATTENTION:** reassemble the valve in the correct manner paying special attention how to set the valve as described in the paragraph PRESSURE ADJUSTMENT/SETTING.

Maintenance has to be carried out by Specialized Technicians.

**The manufacturer is not to be considered responsible for damage as a result from incorrect fitting and maintenance**

Technical data, descriptions and illustrations are indicative and liable to modification without notice

#### REGULATIONS : see norm manual

For a correct utilization, follow the directions described in this manual and re-print them on the Use and maintenance manual of the machine.

Make sure that you are given **the Original Conformity Declaration** for the accessory chosen. The present manual is valid for all un-loader valves named **VS160 – VS30**.

60.0560.00 VS160 saf.valv.1/4M-1/8F Bsp/13mm h.barb

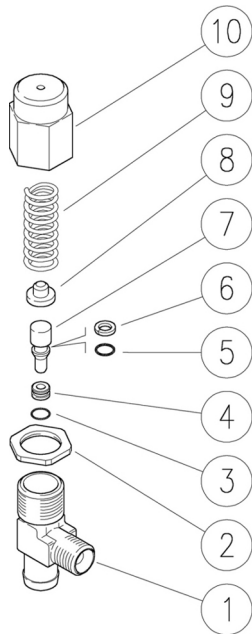

60.0560.30 VS30 saf.valv.1/4M-1/8F Bsp/13mm h.barb

Pos.	P/N	Description	Q.ty	K1	K2	K3	K4	
1	60.0561.35R	Valve housing -VS160-30, brass	1					3
2	60.0317.31R	Locknut, M18x1 brass	1					10
3	10.3002.01R	O-ring, 1x5 mm Ni 85	1	•				10
4	60.0564.51R	Seat, 3,3x7x4 mm Sst.	1	•				5
5	10.3049.01R	O-ring, 1,78x5,28 mm	1	•				10
6	10.4002.52R	Back-up ring, 5x8x1,5 mm	1	•				10
7	60.0562.51R	Piston, 8mm Sst.	1					5
8	60.0310.61R	Spring guide, z.pl.	1					10
9	60.0563.61R	Spring, 3x12,6x33 mm z.pl.	1					10
9	60.0567.61R	Spring, 2,2x10,2x33 mm z.pl. (1)	1					5
10	60.0304.31R	Valve regulating knob, brass	1					5

Kit	P/N	Description	
K1	60.0566.24	Spares kit -VS160-30, 4x1pcs.	1
(1) 60.0560.30			