

P.A. – S.p.A. – EQUIPAGGIAMENTI TECNICI DEL LAVAGGIO

VIA MILANO, 13 – CASELLA POSTALE 115 – 42048 RUBIERA (REGGIO EMILIA) – ITALY
 Tel. +39 0522 623611 – Fax. +39 0522 629600 – R.E.A. RE 156319 – R.I. RE11535 – Mecc. RE 013446
 C.F. e P. IVA 01035950359 – Cap. Soc. i.v. € 750.000,00 – Codice Identificativo C.E.E. IT 01035950359
 ART. 2497 – BIS C.C. DIREZIONE E COORDINAMENTO BENETTI srl R.I. TRIB. DI RE 01480690351
Web: <http://www.pa-etl.it> – **E-mail:** info@pa-etl.it

VB 40/1000 Zero - Flow sensitive unloader valve**PATENTED**

Pressure regulating valve unloader type with zero setting on delivery line: at gun closure the water flow is bypassed at low pressure maintaining also the delivery line in low pressure.

Technical manual: MPA0004EN**DN 10**

- **60.2900.XX** VB 40/1000 Zero G 3/8" FF
 - Near total zero setting of the pressure in the delivery line at gun closure.
Advantages:
 - Increased safety for the operator.
 - Delivery hose easy to control when gun is closed.
 - Less force needed to reopen the gun.
 - At gun reopening, work pressure is reached gradually.
Advantages:
 - Operators work less heavy.
 - Easy starting if thermal engine is used.
 - Reduced pressure loss and hardly dependent on flow rate.
 - Great reliability.
 - Easy maintenance.
 - One standard version and three versions with a single operating pressure for optimised use with different flow ranges: 9-15 l/min - 16-25 l/min - 26-40 l/min.

TECHNICAL SPECIFICATIONS**Construction material: Sst.**

PART NUMBER	MINIMUM FLOW		MAXIMUM FLOW		WORK PRESSURE		ADJUSTABLE MINIMUM PRESSURE		MAX TEMPERATURE (1)		WEIGHT		IN OUT	BYPASS
	l/min	USG	l/min	USG	bar	MPa	bar	MPa	°C	°F	g	oz.		
60.2900.00	9	2.4	40	10.5	1000	100	500	50	95	203	4650	164	G 3/8" F	G 3/8" F
60.2900.12	9	2.4	15	4.0	1000	100	500	50	95	203	4650	164	G 3/8" F	G 3/8" M
60.2900.20	16	4.2	25	6.5	1000	100	500	50	95	203	4650	164	G 3/8" F	G 3/8" M
60.2900.30	26	6.9	40	10.5	1000	100	500	50	95	203	4650	164	G 3/8" F	G 3/8" M

- 1) The valve has been designed for a continuous use at a water temperature of **60°C (140°F)**. It can work for short periods at a maximum temperature of **95°C (203°F)**.

MISURE DI INGOMBRO

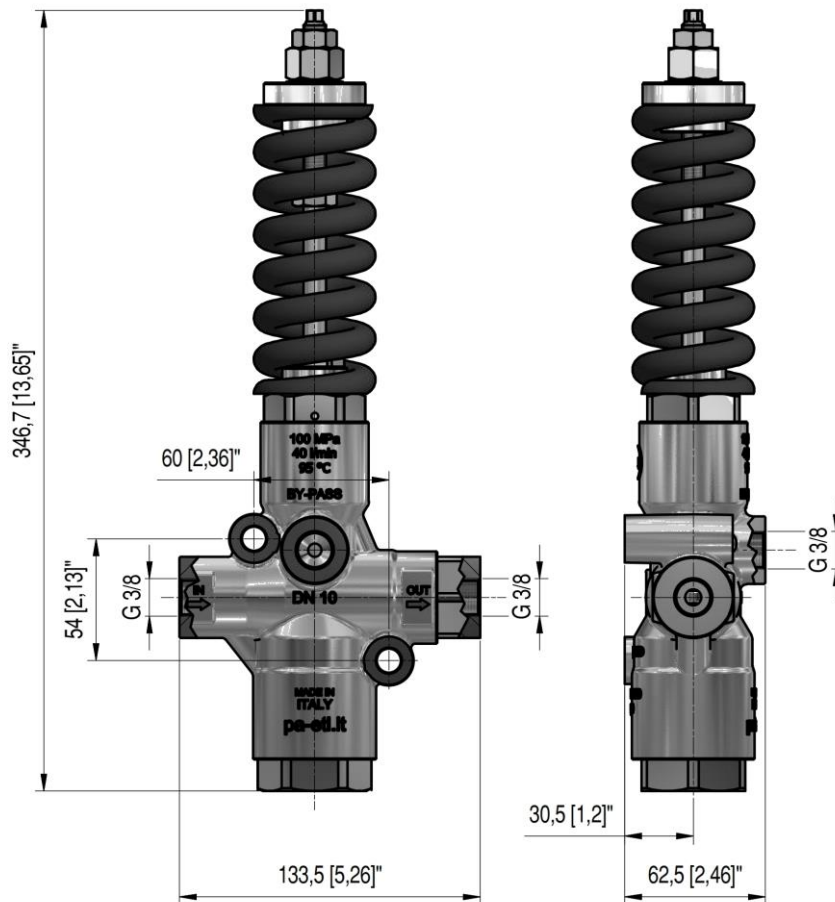

SELECTION

This product is intended to be incorporated on a finished machine. This product is to be utilized with clean fresh water, even slightly additivated with normal detergents. For use involving different or corrosive liquids, contact the PA Technical department. Appropriate filtration should be installed when using unpure liquids. Choose the valve in line with the working data of the machine where to be installed (permissible pressure, maximum flow and rated temperature of the system). In any case, the pressure of the machine must not exceed the **permissible pressure** imprinted on the valve.

Attention. The VB40/1000 Zero valve is sensitive to water flow: at gun opening (water flow through the valve) the system goes into pressure, at gun closure (flow interruption) the system works at low pressure. For this reason, the VB40/1000 zero valve cannot be installed on systems that fit always weeping antifreeze systems. Instead it can be installed on systems with antifreeze systems weeping at low pressure. In this case it is necessary to create in the bypass line a pressure higher than the pressure at which the antifreeze system becomes weeping.

OPERATIONS

The valve regulates the maximum pressure of the system by varying the flow discharged by the bypass. The adjustment is made by altering, by means of a piston, the position of a sphere which closes partially the bypass opening.

The valve is sensitive to water flow. At gun opening, the water flows through the valve which maintains the system in pressure. At gun closure, the interruption of the flow provokes the complete aperture of the bypass which allows to discharge the flow at low pressure. At gun closure, the special mechanism of zero setting patented by PA, which does not include a check valve, keeps in connection the delivery line and the bypass line, in that way permitting to lower the pressure all around the system and not only in the source line of the valve.

INSTALLATION

This accessory, on a system that produces hot water, must be fitted upstream the heat generator. On a system that generates hot water, it is advisable to fit in accessories that limit the accidental increase of fluid temperature.

Do not install the valve on the pump head: secure the valve to the machine's frame by means of the fixing holes obtained on the body. In this way the valve is subject to less vibrations, reducing therefore the wearing of the internal parts. The hose from the pump to the valve must have a minimum length of about one meter. **Always install a safety valve for protect the system.**

If the nozzle wears out, the pressure decreases. To reset pressure back at work level, it is necessary to replace the worn nozzle. When a new nozzle is fitted, re-setting of the system to its original working pressure is required.

DISCHARGE SYSTEM AND WATER ADDUCTION

The valve can be fitted on machines fed directly by the water system with bypass recycle to the pump or on machines fed by a tank where the bypass flow is also discharged.

In certain conditions, depending on installation and in particular:

- o through feeding from tank,
- o with long delivery lines or strong difference in level,
- o with low flow rate and small flow factor nozzles,

it could occur that at gun opening, a delay in the reset of the working pressure is revealed or a pulsation of the valve. To avoid such inconveniences, it is necessary to guarantee always a pressure of at least 3-5 bar in the bypass line. This pressure can be obtained by throttling the bypass line in one of the following ways:

- o fitting in the bypass channel a 3/8" hose instead of 1/2"
- o fitting in the bypass channel a rigid tube of a sufficiently small diameter
- o in case you are using the version code. 60.2900.00, mounting in the bypass a fitting with a hole of a diameter suitable for the flow rate (available on request; see table below)

Connector available on request			
Flow (l/min)	Ø Bore (mm)	Thread	Part Number
9-15	2,7	G 3/8" M	60.2926.51
16-25	4.0	G 3/8" M	60.2927.51
26-40	4.5	G 3/8" M	60.2928.51

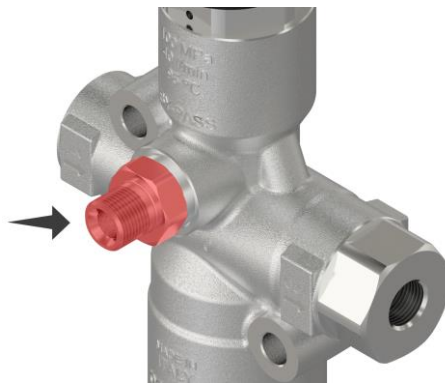

In the case of feeding from the tank where also the bypass flow is discharged, it would be advisable to fit in the feed line of the machine a low pressure pump that guarantees a feed pressure of the high pressure pump of 3-5 bar (See paragraph "EXAMPLES OF INSTALLATION" Picture 4).

It is advisable that the tank be provided with deflectors to reduce eventual turbulence and air bubbles, generated by the intake of the bypass flow, which could be harmful for the pump.

In the case of direct pump recycle of the bypass flow and if bypass conditions are foreseen frequently or for a long time, it is advisable to fit a thermal protector valve (VT3 or VT6) in order to avoid dangerous overheating of recycled water.

PRESSURE ADJUSTMENT/SETTING

The desired working pressure must be adjusted while the system is in operation and the gun is opened. Adjust the pressure by screwing or unscrewing the adjustment nut, taking care to lock the threaded piston with a second wrench, as shown in the picture.

The operation is easier if the correct nozzle has been chosen (see paragraph "installation").

Pressure is increased by screwing the adjustment nut. In case pressure does not increase despite screwing of the nut, **do not force**, but check that the nozzle flow rate/pressure ratio is correct.

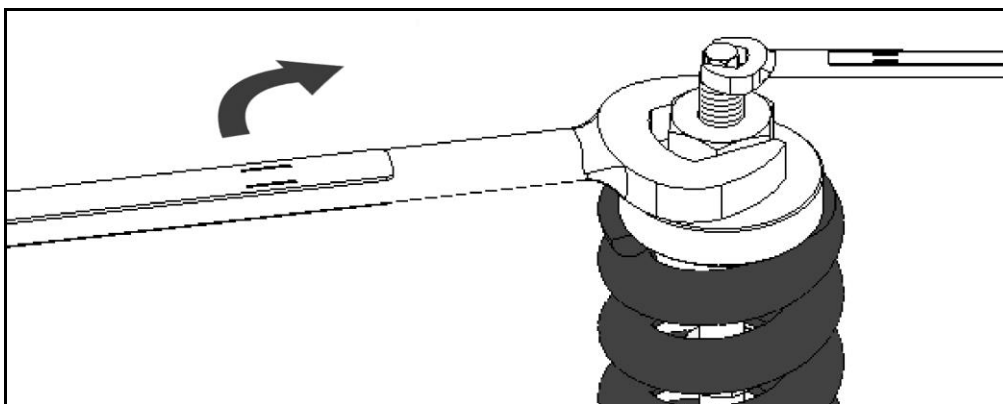

EXAMPLES OF INSTALLATION

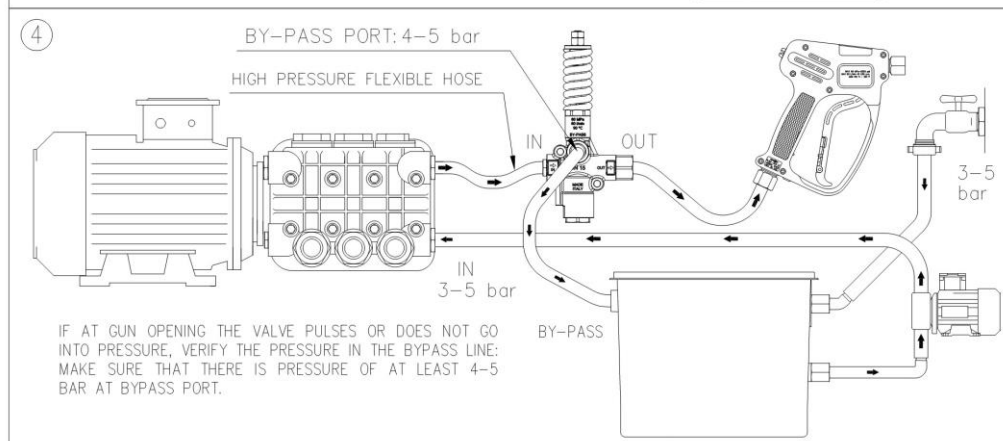
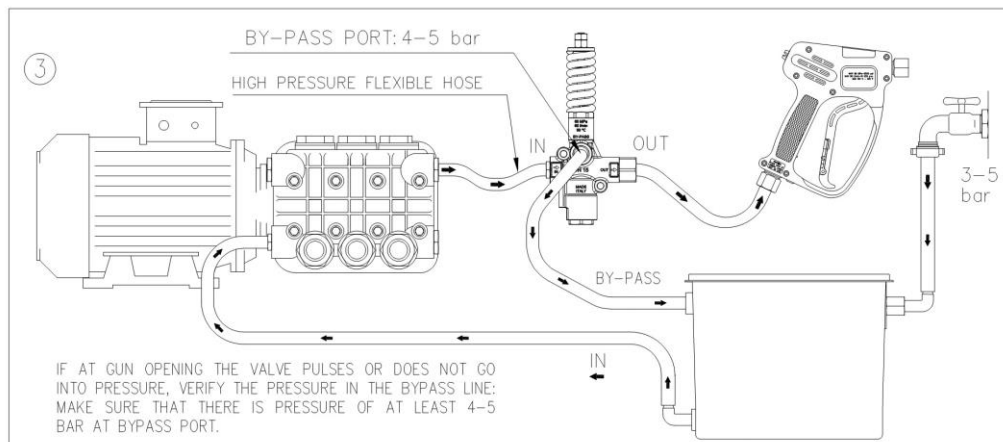
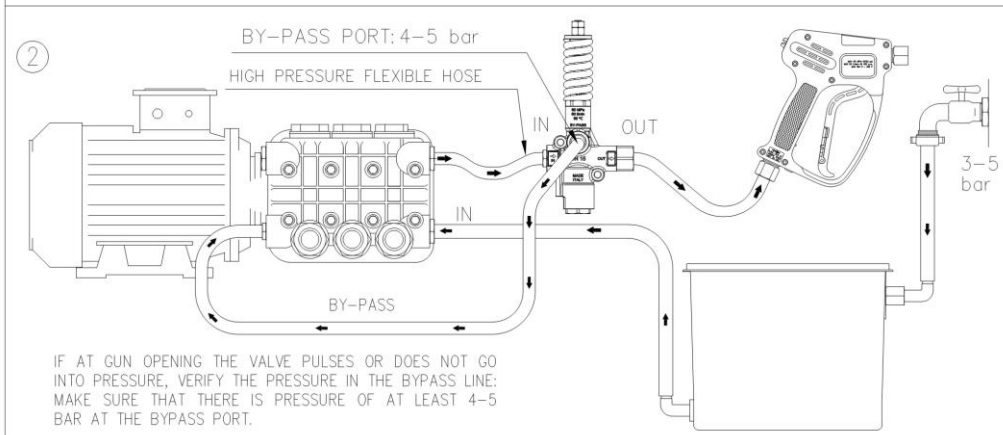
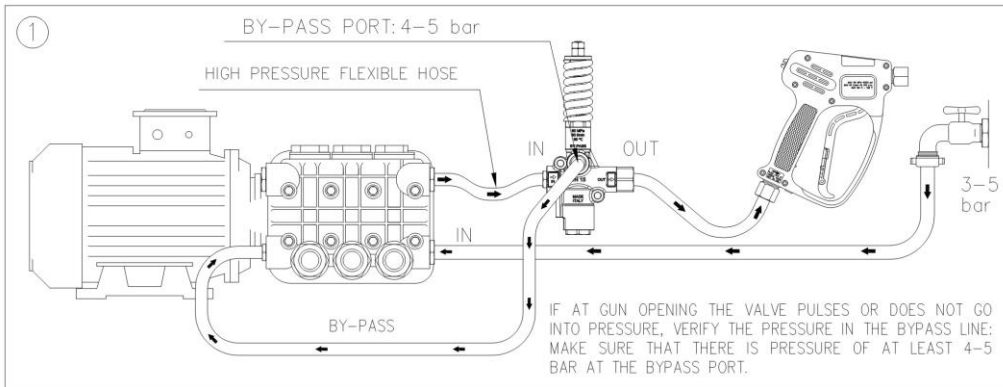

TROUBLE SHOOTING

PROBLEMS	PROBABLE CAUSE	REMEDY
The valve is noisy.	Nozzle with very small flow factor (< 03). Too much water in the bypass unloading.	Size the nozzle according to the flow of the pump in order to decrease the water unloading in the by-pass.
At gun opening much time is required to reach working pressure.	Delivery hose very long or big level difference between valve and gun. Nozzle with very small flow factor (< 03)	Throttle bypass unloading. See section: DISCHARGE SYSTEM AND WATER ADDUCTION
At gun closure the valve pulses (rearm).	Flow rate of the pump pulsating.	Check the pump.
	Delivery hose too short.	Provide a longer hose.
	The pump is sucking air in.	See section: DISCHARGE SYSTEM AND WATER ADDUCTION
At gun closure the valve pulses (rearm)	Big leakage from the gun Leak from delivery line	Eliminate the leakage
At gun opening the valve does not go under pressure and continues to unloading into the bypass.	Delivery hose very long or big level difference between valve and gun. Nozzle with very small flow factor (< 03)	Throttle bypass unloading. See section: DISCHARGE SYSTEM AND WATER ADDUCTION
At gun closure, the valve does not lower the pressure on the delivery line.	Orifice of the shutter blocked (pos.33 on exploded view).	Clean and eliminate obstruction.
Valve does not reach maximum pressure.	Worn nozzle.	Replace
	Presence of matter between seat and shutter	Clean the seat
	Seat damaged or worn	Replace
Valve does not go into pressure.	O-rings of Sst piston (pos. 8-9-10 e 13-14-15 of the exploded view) ruined.	Replace

MAINTENANCE

STANDARD: every 400 working hours, check and lubricate the seals with water resistant grease.

SPECIAL: every 800 working hours, check the wear of the seals and internal parts and, if necessary, replace with original PA parts taking care, during installation, to lubricate with water resistant grease.

The maintenance must be carried out by specialized technicians.

The manufacturer is not to be considered responsible for damage as a result from incorrect fitting and maintenance.

REGULATIONS

For a correct utilization, follow the directions as described in this manual and re-print them on the Use and maintenance of the machine. If needed, ask for the original Conformity Declaration for the accessory chosen. The present manual is valid for all unloader valves named **VB 40/1000 Zero**.

Technical data, descriptions and illustrations are indicative and liable for modification without notice.

Instruction manual, maintenance, installation, spare parts. <u>For a correct utilization, follow the directions of this manual and re-print them on the Use and Maintenance booklet of the machine.</u>	n. MPA.0004.EN
---	----------------

60.2900.00 VB40/1000 Zero Unload.-flow activated

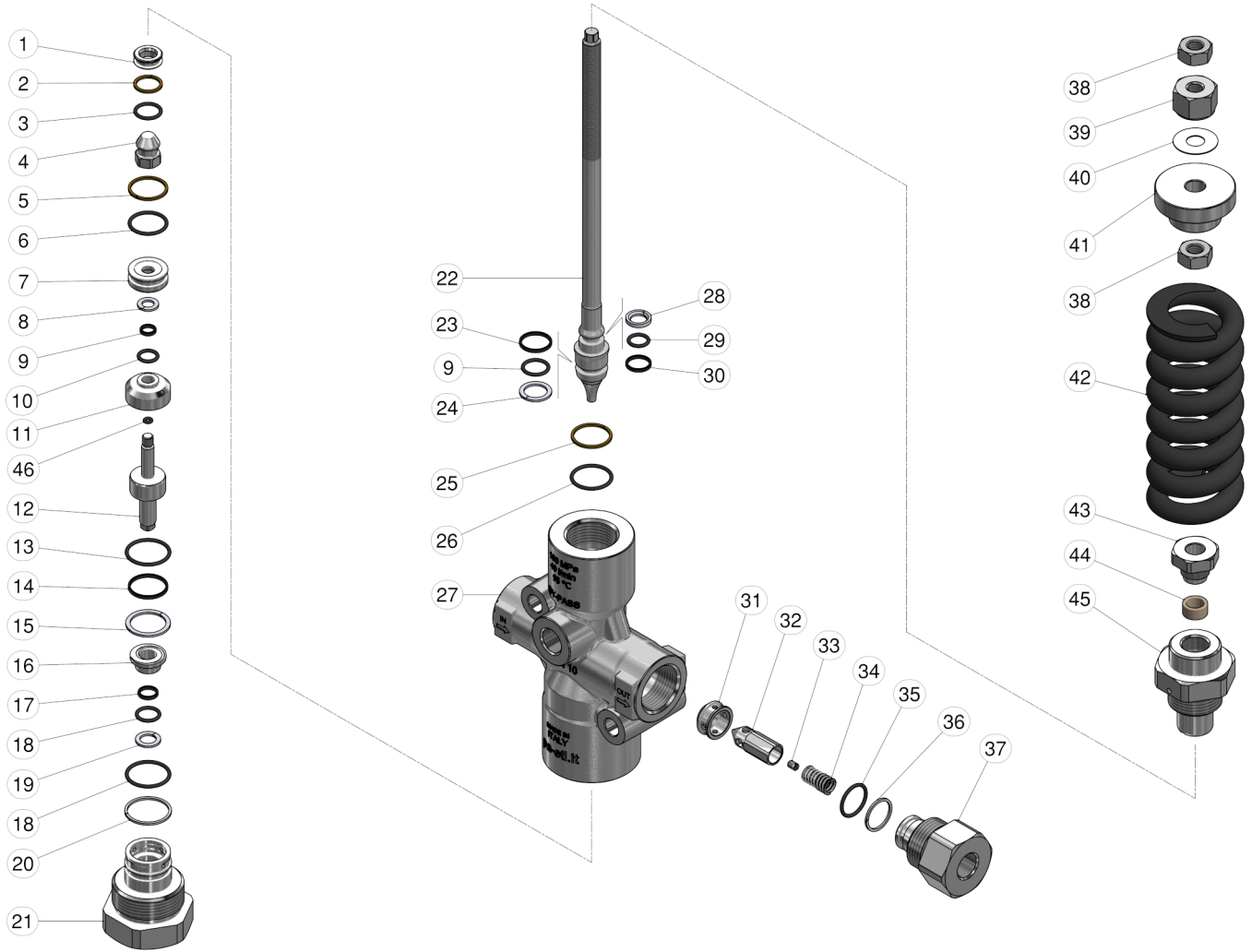

Pos.	P/N	Description	Q.ty	K1	K2	K3	K4		Pos.	P/N	Description	Q.ty	K1	K2	K3	K4	
1	60.2919.51R	Sst seat, 9,5 mm	1	•				5	24	10.4013.09R	Back-up ring, 13,1x18x1,2 mm	1	•				10
2	10.4013.00R	Back-up ring, 16x13,2x1,2 mm	1	•				10	25	10.4060.09R	Back-up ring, 20x22,8x1,2 mm	1	•				10
3	10.3060.85R	O-ring, 1,78x12,42 mm HNbr 85	2	•				10	26	10.3072.95R	O-ring, 1,78x20,35 mm HNbr 85	1	•				10
4	60.2925.51R	Sst shutter v.2	1	•				5	27	60.2905.55R	Housing -VB40/1000 Zero 3/8 .Bsp F sst	1	•				3
5	10.4041.00R	Back-up ring, 19,3x22x1,2 mm PTFE	1	•				10	28	10.4008.93R	Back-up ring, 9,3x14,2 x2,2 mm	1	•				5
6	10.3070.85R	O-ring, 1,78x18,77 mm HNbr 85	1	•				10	29	10.3057.85R	O-ring, 1,78x9,25 mm HNbr 85	1	•				10
7	60.2906.51R	7 mm sst piston ring	1					3	30	10.4162.00R	Back-up ring, 14,2 mm	1	•				3
8	10.4007.09R	Back-up ring, 7x11,9x1,2 mm	1	•				10	31	60.2911.51R	Sst. seat check valve	1					5
9	10.4007.92R	Back-up ring, 7x9x2 mm	1	•				10	32	60.2931.21R	Sst shutter+nozzle VB40/1000	1					3
10	10.3056.85R	O-ring, 1,78x8,74 mm HNbr 85	1	•				10	34	60.2601.51R	Sst spring, 1,3x8,5x28,5 mm	1					10
11	60.2909.51R	7 mm sst piston ring	1					3	35	10.3068.85R	O-ring, 1,78x17,17 mm HNbr 85	1	•				10
12	60.2924.51R	Sst pin v.2	1					5	36	10.4099.00R	Back-up ring, 17,2x20x1,2mm	1	•				10
13	10.3072.85R	O-ring, 1,78x21,95 mm HNbr 85	2	•				10	37	60.2912.51R	Shutter coupl., 3/8F Bsp sst	1					3
14	10.4059.00R	Back-up ring, 20x22x2 mm	1	•				10	38	11.4629.00R	Hex. nut, M10	2					10
15	10.4059.09R	Back-up ring, 20x24,9x1,2mm	1	•				10	39	60.2917.61R	Hex. nut, M10 zpl.	1					5
16	60.2610.51R	9,2 mm sst piston ring	1					3	40	60.2918.51R	Washer, 10,3x25x0,5 Ai301	1					5
17	10.4055.00R	Back-up ring, 9,2x11,2x2 mm	1	•				10	41	60.2914.51R	Spring holding washer, sst	1					5
18	10.3058.85R	O-ring, 1,78x10,82 mm HNbr 85	1	•				10	42	60.2901.61R	Spring, 12x42x128 mm black	1					1
19	10.4008.09R	Back-up ring, 9,2x14,1x1,2 mm	1	•				10	43	60.2915.51R	Sst. M16x1 plug, **	1					5
20	10.4098.00R	Back-up ring, 23,2x26x1,2mm	1	•				10	44	26.1046.84R	Bushing, 10x14x7 mm Plast. **	1	•				10
21	60.2904.51R	Lower plug, sst	1					3	45	60.2903.51R	Piston holder, sst	1					5
22	60.2902.21R	Sst. valve piston, VB40/1000 Zero	1					5	46	10.3014.25R	O-ring, 1,5x2,5 mm Ni 70	1					10
23	10.4161.00R	Back-up ring, 18 mm	1	•				3									

** On request

Kit	P/N	Description	
K1	60.2921.24	Spares kit -VB40/1000.Zero, 26x1pcs.	1